



MULTIWARM

HIGH TECH INNOVATION

2026

air conditioning
general catalogue

multiwarm.it

MULTIWARM

HIGH TECH INNOVATION

Multiwarm offers products capable of optimising the energy performance of buildings for heating, cooling and the production of domestic hot water.

High tech innovation, total Multiwarm comfort

MULTIWARM is a brand of the Termal Group, leader in Italy in the air conditioning sector.

Technologically advanced, MULTIWARM systems are perfectly in line with residential and commercial design needs, to achieve high quality standards.

Contents

3	TERMAL GROUP: EXPERIENCE THAT GUIDES THE FUTURE
4	PRE-SALES AND AFTER-SALES SERVICE
6	TERMAL ACADEMY TRAINING
8	LA RETE COMMERCIALE
9	INNOVAZIONE
10	TECHNOLOGY AND ENVIRONMENT
13	RESIDENTIAL & LIGHT COMMERCIAL R32 MONOSPLIT AND MULTISPLIT MULTIOMNIA
55	VRF SYSTEMS MW MINI - MW 2-PIPE - MW 3-PIPE
93	INDOOR UNITS VRF SYSTEMS MW MINI - MW 2-PIPE - MW 3-PIPE
111	AIR-TO-WATER HEAT PUMP MONOBLOC MODULAR MONOBLOC SPLIT R32 AIR-TO-WATER HEAT PUMP
135	CONTROLS



Termal Group, experience that guides the future

Technological research, a love of challenge and the ability to interpret the future are our entrepreneurial heritage

These principles are the foundation of a history that has been developing for over 40 years, of a commitment that has evolved in the pursuit of excellence and continuous improvement.

Termal Group

Termal is a commercial group that was founded in the 1980s. A history that has developed over more than **40 years** of dynamic activity, a commitment that has evolved in the pursuit of excellence and continuous improvement. Termal is currently a group consisting of a network of companies and is a leading player in the Italian and European **climate and comfort sector**.

In the 2010s, the **Multiwarm** brand began distribution, created to meet the need for **total thermal comfort** in residential and mid-to-large commercial applications through technological excellence and consistently high quality standards.

Termal quality

- > Direct logistics;
- > Academy for continuous training;
- > Extensive network of service centres;
- > In-house technical office for product development;
- > Pre- and post-sales service.



Pre-sales and after-sales service

Termal Assistance Portal, the reference point for assistance

The Termal Assistance Portal provides centralised and efficient technical assistance for Multiwarm products.

The platform can be accessed at **www.assistenzatermal.it**; customers and technical assistance centres can access it to submit their support requests through a clear interface, personalised access and linear operational flows.

An environment where, through simple workflows, support requests can be submitted and the necessary documentation accessed.

Each request is automatically forwarded to the relevant department, ensuring effective management and optimised response times.



Centralised access

A single portal for all support needs.



Simplified experience

Intuitive interface for all types of users, with guided paths.



Efficiency and speed

System that simplifies communication with the relevant departments and reduces response times.



Integrated management

Each flow generates a notification to the correct department and links to secondary portals (manuals, spare parts).



WWW.ASSISTENZATERMAL.IT



Advantages for installers, designers and wholesalers

The portal dedicated to **professional operators** offers a complete set of tools for every phase: from design to commissioning, right through to after-sales support.

Each profile – installer, designer or wholesaler – finds technical resources, specific modules and support materials that facilitate daily work, reduce response times and guarantee a high level of service to the end customer.



Start-up and after-sales service

Just a few clicks to send us your request for product commissioning or after-sales assistance on already installed products.



Spare parts management and after-sales service

Dedicated area for requesting original spare parts and support for products that have already been installed.



Documentation requests

Quickly obtain manuals, diagrams, technical specifications and official support materials.



Design specifications

Tools for defining technical requirements, system diagrams and design configurations.

Advantages for CATs and self-service customers

The portal offers CATs and self-service customers a structured environment in which to operate efficiently and independently.

The features are designed to meet the **needs of those who work with the product** on a daily basis, providing direct specialist technical support and access to the most up-to-date documentation.

To streamline the compilation of requests, these users can **log in**.



Specialised technical support

Access to dedicated channels to request in-depth assistance on complex issues or technical interventions.



Access to technical documentation

Manuals, certifications and technical specifications are always available and up to date.



Spare parts management

Reserved area for selecting and requesting original spare parts needed for field interventions.

Termal Academy training



Termal Academy

Training that becomes operational expertise. In Bologna, at the heart of the Termal Group

The Termal Academy is the training department of the Termal Group: a team of engineers and specialised technicians who transfer practical know-how on air conditioning, heating and domestic hot water

An environment where, through simple flows, you can submit requests for assistance and access the necessary documentation.

production systems from the brands distributed by the Group on a daily basis.

We are located in Bologna, where theory meets real-life systems in operation and training becomes performance in the field.



Who it is aimed at

Installers, designers, specialised technicians. Professionals who want to work to the highest standards, keep up to date with the latest developments and transform technical expertise into value for the customer and new business opportunities.

Our method

- > **Theory + practice:** each course combines lectures, demonstrations and tests on working systems.
- > **Operational approach:** focus on installation, assistance, maintenance and fault diagnosis.
- > **Continuous updating:** programmes always aligned with new products, technological developments and regulatory changes.

The headquarters and laboratories

At our Bologna headquarters, you will find:

- > **Theory classrooms** for structured in-depth study.
- > **Demonstration** and practical **classrooms** with real systems from the various product families (residential, commercial, VRF and hydronic systems) and related control instruments.

This is where you really learn: by touching, measuring and configuring.

HVAC training content

- > Refrigeration circuit and best installation practices.
- > Fault diagnosis and service procedures.
- > Design of **VRF systems or air-water heat pumps**.

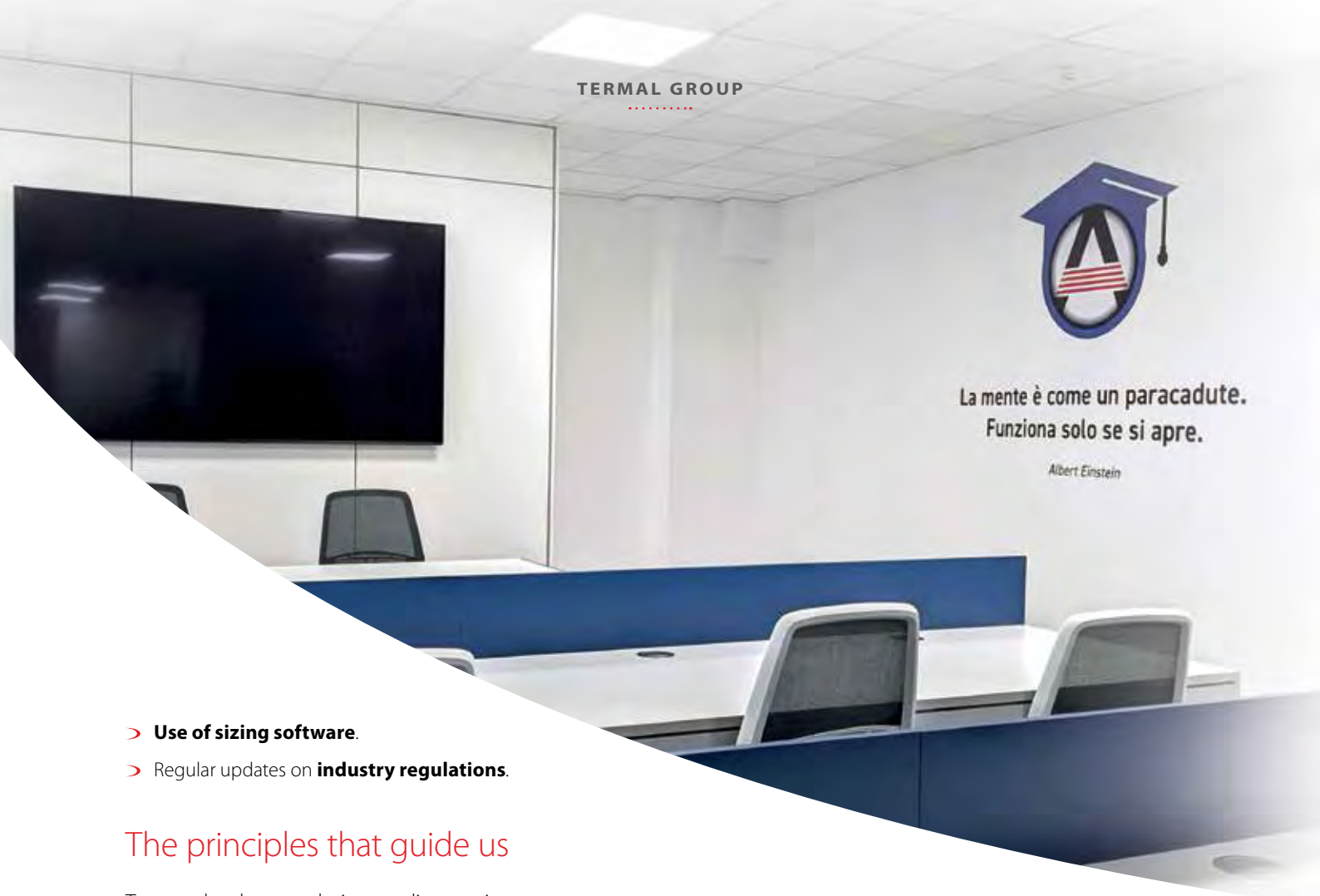

- > **Use of sizing software.**
- > Regular updates on **industry regulations.**

The principles that guide us

Trust, technology, evolution, quality, continuous training. These are our five guiding principles: we believe in people and their development. Experienced professionals are at your side to tackle the challenges of everyday work and always stay one step ahead.

Strategies for the future

The TERMAL Academy offers regular, **highly specialised programmes** on innovative HVAC products and solutions. Not just technical skills: we also focus on marketing and sales techniques to improve customer relations and communication, so that we can truly meet their needs.

What you take home

- > Up-to-date and immediately applicable **operational skills.**
- > **Certificate of attendance** and complete technical **handouts** for each module.
- > A network of specialists with whom you can continue to exchange ideas even after the course.



The Multiwarm sales network: specialist installers and wholesalers

Multiwarm provides full support to its network through an advanced logistics hub serving all operational activities.

MULTIWARM products, highly specialised in air conditioning, heating and domestic hot water (DHW) production, are distributed through a selected network of **specialist installers and wholesalers** with extensive coverage across Italy and Europe.

The central warehouse is located in Bologna at the Termal Group, supported by external logistics partners, providing operational support and dedicated services to the entire network.

This structure enables Multiwarm's installer and wholesaler partners to offer customers strong operational and commercial flexibility and, as a result, strong competitiveness in different local markets





Air conditioning at your fingertips



Wi-Fi

Wi-Fi technology at the service of the Residential, Light Commercial and VRF product ranges.

The VRF and Residential MULTIWARM air conditioning systems allow you to control the air conditioning system, both at home and away, using applications available for iOS and Android devices (standard and optional).

Through MULTIWARM applications it is possible to manage your air conditioning system, for correct comfort and attention to consumption.

Mission: environmental protection

Multiwarm products contribute to significantly improving climate comfort, achieving substantial energy savings, and safeguarding the environment.

MULTIWARM is at the forefront in the supply of efficient and innovative air conditioning systems, capable of ensuring comfort and savings on bills.

To air condition domestic and commercial environments, the systems must have at least these characteristics:

- energy efficiency and reduced consumption;
- innovation, functional standard and remote controls;
- low emissions for maximum environmental protection;
- design, the refinement of the materials and the aesthetic aspect are important elements in the choice of a product;
- silence;
- ease of use.







RESIDENTIAL & LIGHT COMMERCIAL R32

RESIDENTIAL & LIGHT COMMERCIAL MONOSPLIT AND MULTISPLIT MULTIOMNIA

14	R32 REFRIGERANT GAS
15	LINE UP RESIDENTIAL MONOSPLIT R32
16	ACTION
20	CONSOLE
21	LINE UP LIGHT COMMERCIAL MONOSPLIT R32
22	> INDOOR UNITS
29	LINE UP RESIDENTIAL & LIGHT COMMERCIAL MULTISPLIT R32
30	> OUTDOOR UNITS R32
33	MULTIOMNIA DHW HEAT RECOVERY R32
40	RESIDENTIAL & LIGHT COMMERCIAL MULTISPLIT INDOOR UNITS
44	COMBINATIONS

R32, MORE PERFORMANCE, LESS ENVIRONMENTAL IMPACT

Advantages of R32

Nowadays, environmental protection is considered of primary importance by both users and professionals.

Choosing an air conditioner with the new R32 refrigerant allows you to obtain excellent comfort in both cooling and heating while reducing polluting emissions.

The most relevant aspect of R32 gas is its GWP value, equal to 675, which allows the creation of systems containing up to 74 kg of gas without exceeding the threshold that requires leak control and keeping an equipment register, a threshold that for an R410A gas is already exceeded by 2.4 kg of gas

R32 refrigerant:

- it's eco-friendly;
- **it is non-toxic;**
- it is slightly flammable;
- it is not harmful and does not pose a risk to the ozone layer;
- it is very efficient.



LOWER ENVIRONMENTAL IMPACT

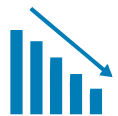

REDUCTION OF THE GREENHOUSE EFFECT

Why choose R32

The specific name of R32 gas is difluoromethane. It is currently present among the fluorinated gases with a low GWP value, equal to 675, and used in air conditioning appliances intended for residential use.

There is no obligation to replace the current R410A gas, which therefore remains regularly on the market, except in monosplit applications with refrigerant < 3 kg where, from 2025, the use of gas with GWP < 750 will be mandatory for new installations.

There are some limitations in particular conditions of use that must be considered in accordance with the Regulations in force.

Storage, standards and design

When storing units containing R32, it may be necessary, based on the quantities stored, to review the Fire Prevention Certificate (DPR 151/2011) to ensure the validity of your insurance guarantee. The transport of dangerous goods is regulated by D.GLS 35/2010. R32 has been classified as slightly flammable by ISO 817 and as such has no stringent limitations in road transport (current ADR), maintaining strict regulations in maritime transport (current IMDG) and aeronautical transport (current IATA).

The EN 378:2016 standard also regulates the applications of appliances that use R32 gas; the maximum concentration limits of the gas in residential applications must always be verified with particular attention to multisplit systems that can potentially concentrate (in the event of

leaks) high quantities of refrigerant in small spaces. **R32 gas is heavier than air and in case of leakage it accumulates at the bottom;** therefore, the indoor units follow different regulatory parameters depending on the type of application.

Installation in public buildings is regulated by specific regulations relating to the application of appliances with flammable gases, such as: hotels DM 09/04/1994, shopping centres DM 27/07/2010, buildings for entertainment DM 19/08/1996, hospitals DM 18/09/2012, schools DM 26/08/1992, offices DM 22/02/2006, children's games DM 16/07/2014, airports DM 07/07/2014, interports DM 18/07/2014.



The design, installation and maintenance of appliances with R32 gas are regulated by the following standards: DM 37/2008, provisions on the installation of systems inside buildings; DGLS 81/2008, text on health and safety at work; F-gas 517/2014, regulation of fluorinated gases; DPR 151/2011, regulation of procedures relating to fire prevention; EN 378:2016, refrigeration systems and heat pumps (requirements for the safety of systems).

With the Ministerial Decree of 10 March 2020 and the subsequent Circular DCPREV 9833 of 22 July 2020 by the Fire Brigade, the technical provisions are updated to allow the possibility of using, in air conditioning and conditioning systems, machines equipped with refrigerants classified as A1 or A2L, thus overcoming the restriction of using only non-toxic or non-flammable fluids.

However, it is recommended to carefully check the regulations in force when using equipment containing R32 gas. Failure to comply with these regulations makes designers and installers of equipment with R32 assume direct legal responsibility for the application of the equipment itself.

RESIDENTIAL MONOSPLIT R32

INDOOR UNITS

		2.60	3.50	5.30	7.10
ACTION	 MKEGM-ZAL	✓	✓	✓	✓
CONSOLE	 MFIGM-ZAL	✓	✓	✓	

OUTDOOR UNITS





ACTION

The new Action ensures accurate control of thermal comfort while remaining silent and efficient.

Energy savings

A++

Energy class in cooling
(capacities from 2.5 to 6.2 kW)

A+

Energy class in heating
(capacities from 2.5 to 6.2 kW)

Operating range

up to

43°C

in cooling

down to

-15°C

in heating

Maximum silence

21 dB

Excellent silence levels in low mode
(capacity 2.5 kW)

Smart Wi-Fi integrated as standard

With Smart Wi-Fi technology you can turn the air conditioner on and off, as well as set the cooling or heating mode, adjust the air flow and check the proper functioning of the system.



Management via EWPE Smart app

FEATURES AND FUNCTIONS

Turbo function

With the turbo function the air flow is very powerful, in a horizontal position towards the ceiling when cold, towards the floor when hot, to quickly reach the desired temperature.



4-way air delivery

The flaps can be adjusted both horizontally and vertically, to maximize comfort.



Self-Clean function

One of the main causes of bad odors is mold and bacteria. The Self-Clean function dries the inside of the air conditioner to prevent their formation by eliminating residual humidity inside the indoor unit. This function works by significantly reducing bad odors and therefore allows you to get cleaner air from the air conditioner.

Cold Plasma Filter

The plasma purification system produces clusters of ions that collide, capture and destroy odors, bacteria, pollen and allergens, in order to reduce the symptoms of allergies and asthma.

I-Feel function

The sensor built into the remote control senses the surrounding temperature and transmits the signal to the indoor unit. This allows the indoor unit to adjust the volume and temperature of the air flow to ensure maximum comfort.



Remote control with "I FEEL", actual temperature 26° C, perceived temperature 26° C.



Remote control without "I FEEL", actual temperature 29° C, perceived temperature 26° C.





Quiet Design

This is the mode in which the indoor unit fans work at low speed and the operating sound is reduced to a minimum.

Intelligent pre-heating

The air is brought to temperature before being released into the environment.

Self-diagnosis

The controller detects the error, displays the corresponding code and stops operation.

8°C mode

It never lets the room temperature drop below 8°C, which is very useful to prevent an apartment from deteriorating due to excessive cold during the winter season.

Other functions

Timer, Auto restart, Key lock, LED lights, Turbo cooling, Low voltage start.

Quick defrost

The outdoor unit detects any freezing and activates the rapid defrosting procedure to improve heat dissipation.

Standby

When the unit finishes its operation and is turned off, the consumption is less than or equal to 1 Watt.

7 fan speeds

From super-low to turbo, choose the speed you want.

Soft Start

When power returns after an outage, the units restart gradually to avoid energy overload.

ACTION

4 CAPACITIES
2.50~6.20 kW

ELEGANT & COMPACT DESIGN
185 mm depth for the 2.50 kW model
200 mm depth for the 3.20 kW model

MAXIMUM SILENCE
solo 21 dB(A) in Low mode
for the 2.50 kW model

I-FEEL FUNCTION
SELF-CLEAN FUNCTION
COLD PLASMA FILTER
REMOTE CONTROL INCLUDED

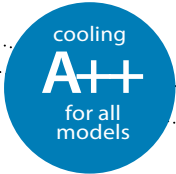

MKEGM 267~717 ZAL

	SEER	SCOP
2.50 kW	6.60	4.10
3.20 kW	6.50	4.10
4.60 kW	7.20	4.00
6.20 kW	6.80	4.00

Indoor unit model		MKEGM 267 ZAL	MKEGM 357 ZAL	MKEGM 537 ZAL	MKEGM 717 ZAL	
Outdoor unit model		MCNGS 267 ZA	MCNGS 357 ZA	MCNGS 537 ZA	MCNGS 717 ZA	
Type		DC-Inverter heat pump				
Control (supplied)		Remote control				
Nominal data						
Nominal capacity (T=+35°C)	Cooling	kW	2.50 (0.50~3.25)	3.20 (0.90~3.70)	4.60 (1.00~5.40)	6.20 (1.80~6.90)
		kW	0.68 (0.15~1.30)	0.93 (0.22~1.30)	1.35 (0.15~1.90)	1.79 (0.45~2.30)
		EER ¹	3.68	3.43	3.40	3.47
Nominal capacity (T=+7°C)	Heating	kW	2.80 (0.50~3.70)	3.40 (0.90~4.10)	5.20 (0.75~5.80)	6.50 (1.30~7.91)
		kW	0.73 (0.14~1.50)	0.87 (0.22~1.50)	1.33 (0.16~1.90)	1.65 (0.45~2.30)
		COP ¹	3.84	3.90	3.89	3.95
Seasonal data						
Theoretical load (Pdesignc)	Cooling	kW	2.50	3.20	4.60	6.20
		SEER ²	6.60	6.50	7.20	6.80
		626/2011 ³	A++	A++	A++	A++
Annual energy consumption	Heating (average weather conditions)	kWh/y	133	172	224	319
		SCOP ²	4.10	4.10	4.00	4.00
		%	161	161	157	157
Theoretical load (Pdesignh) @ -10°C	Heating (average weather conditions)	kW	2.50	2.70	3.70	4.50
		626/2011 ³	A+	A+	A+	A+
		kWh/y	854	922	1295	1575
Electrical data						
Power supply	Outdoor unit	Ph-V-Hz	1Ph - 220/240V - 50Hz			
Power cable		Type	3 x 1.5 mm ²	3 x 1.5 mm ²	3 x 2.5 mm ²	3 x 2.5 mm ²
Connection wires between I.U. and O.U.		no.	4	4	4	4
Nominal absorbed current	Cooling	A	3.10	4.10	6.20	7.60
	Heating	A	3.20	3.90	6.10	7.60
Maximum current		A	6.00	6.50	8.50	11.50
Maximum absorbed power		kW	1.50	1.50	1.90	2.30
Refrigerant circuit data						
Refrigerant ⁴	Type (GWP)	R32 (675)	R32 (675)	R32 (675)	R32 (675)	
Q.ty of refrigerant pre-charge	Kg	0.48	0.59	0.8	1.2	
Tons of CO ₂ equivalent	t	0.324	0.398	0.520	0.817	
Liquid/gas refrigerant pipe diameter	mm (inches)	6.35(1/4) / 9.52(3/8)	6.35(1/4) / 9.52(3/8)	6.35(1/4) / 9.52(3/8)	6.35(1/4) / 12.74(1/2)	
Max split length	m	15	20	25	25	
Max difference in height U.I./O.U.	m	10	10	10	10	
Split length without additional charge	m	5	5	5	5	
Additional charge	g/m	16	16	16	40	
Indoor unit specifications						
Dimensions	LxDxH	mm	708x185x260	835x200x275	943x246x333	943x246x333
Net weight		Kg	7	9	13	13.5
Sound power level	Hi~Lo	dB(A)	55/48/46/44/40/37/33	59/50/47/45/41/38/35	60/58/56/54/48/44/41	65/56/54/52/50/46/42
Sound pressure level	Hi~Lo	dB(A)	38/36/34/32/28/25/21	42/38/35/33/29/26/23	47/45/43/41/35/30/28	50/46/44/42/40/36/32
Volume of air treated	Hi~Lo	m ³ /h	500/470/430/390/320/270/250	650/550/470/420/380/350/310	1000/960/870/810/720/640/600	1050/900/740/690/640/590/540
Outdoor unit specifications						
Dimensions	LxDxH	mm	732x330x555	732x330x555	732x330x555	873x376x555
Net weight		Kg	24.5	25	27.5	36.5
Sound power level		dB(A)	60	63	65	69
Sound pressure level		dB(A)	50	52	55	59
Volume of air treated	Max	m ³ /h	1950	1950	2100	2800
Operating limits (outdoor temperature)	Cooling	°C	-15~43			
	Heating	°C	-15~24			
Optional parts						
Wi-Fi module	Included					
Individual wired control	M-RF-CW2-L-G / M-RF-CW3-L-G					

1. Value measured according to the harmonised standard EN14511. 2. EU Regulation No. 206/2012. - Value measured according to the harmonised standard EN14825. 3. EU Delegated Regulation No. 626/2011 on the new energy consumption labelling of air conditioners. 4. Refrigerant leakage contributes to climate change. When released into the atmosphere, refrigerants with a lower global warming potential (GWP) contribute less to global warming than those with a higher GWP. This appliance contains a refrigerant with a GWP of 675. Therefore, if 1 kg of this refrigerant were released into the atmosphere, the impact on global warming would be 675 times higher than 1 kg of CO₂ over a period of 100 years. Under no circumstances should the user attempt to intervene on the refrigerant circuit or disassemble the product. In case of need, always contact qualified personnel.

CONSOLE

3 CAPACITIES

2.70~5.20 kW

7 FAN SPEED levels

TOTAL TEMPERATURE CONTROL

The *I feel* function detects the room temperature in the remote control position

ELEGANT & COMPACT DESIGN

215 mm depth

DOUBLE AIR DELIVERY

X-FAN allows you to dry the evaporator to prevent the formation of mold and bacteria

COLD PLASMA purification system

8° HEATING

prevents the room temperature from falling below 8°C

REMOTE CONTROLLER INCLUDED

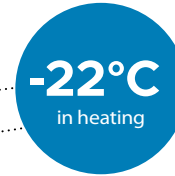
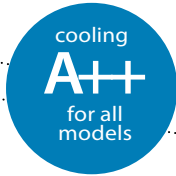

MFIGS 261~531 ZAL





	SEER	SCOP
2.70 kW	7.80	4.20
3.52 kW	7.20	4.10
5.20 kW	7.20	4.00

Indoor unit model	MFIGS 261 ZAL		MFIGS 351 ZAL		MFIGS 531 ZAL	
Outdoor unit model	MCJGS 261 ZA		MCJGS 351 ZA		MCJGS 531 ZA	
Type	DC-Inverter heat pump					
Control (supplied)	Remote control					
Nominal data						
Nominal capacity (T=+35°C)	Cooling	kW	2.70 (0.50~3.40)	3.52 (0.80~4.40)	5.20 (1.20~6.20)	
Nominal absorbed power (T=+35°C)		kW	0.70 (0.15~1.10)	0.93 (0.23~1.55)	1.45 (0.10~2.25)	
Nominal energy efficiency coefficient	Heating	EER ¹	3.86	3.80	3.60	
Nominal capacity (T=+7°C)		kW	2.90 (0.60~3.65)	3.80 (1.05~4.40)	5.33 (1.10~6.20)	
Nominal absorbed power (T=+7°C)		kW	0.73 (0.16~1.20)	0.96 (0.18~1.70)	1.55 (0.20~2.40)	
Nominal energy performance coefficient		COP ¹	3.97	3.96	3.45	
Seasonal data						
Theoretical load (P _{designc})	Cooling	kW	2.70	3.50	5.20	
Seasonal energy efficiency index		SEER ²	7.80	7.20	7.20	
Seasonal energy efficiency class		626/2011 ³	A++	A++	A++	
Annual energy consumption		kWh/y	121	170	253	
Theoretical load (P _{designh}) @ -10°C	Heating (average weather conditions)	kW	2.60	3.20	4.80	
Seasonal performance coefficient		SCOP ²	4.20	4.10	4.00	
Seasonal energy efficiency (η _s)		%	165	161	157	
Seasonal energy efficiency class		626/2011 ³	A+	A+	A+	
Annual energy consumption		kWh/y	867	1093	1680	
Electrical data						
Power supply	Outdoor unit	Ph-V-Hz	1Ph - 220/240V - 50Hz			
Power cable		Type	3 x 1.5 mm ²		3 x 2.5 mm ²	
Connection wires between I.U. and O.U.		no.	4		4	
Nominal absorbed current	Cooling	A	3.50	4.60	6.60	
	Heating	A	3.50	4.60	7.10	
Maximum current		A	6.00	7.50	11.50	
Maximum absorbed power		kW	1.20	1.70	2.40	
Refrigerant circuit data						
Refrigerant ⁴	Type (GWP)	R32 (675)		R32 (675)		R32 (675)
Q.ty of refrigerant pre-charge	Kg	0.51		0.75		1.00
Tons of CO ₂ equivalent	t	0.344		0.506		0.675
Liquid/gas refrigerant pipe diameter	mm (inches)	6.35(1/4) / 9.52(3/8)		6.35(1/4) / 9.52(3/8)		6.35(1/4) / 12.74(1/2)
Max split length	m	15		20		25
Max difference in height U.I./O.U.	m	10		10		10
Split length without additional charge	m	5		5		5
Additional charge	g/m	16		16		16
Indoor unit specifications						
Dimensions	LxDxH	mm	700x215x600		700x215x600	
Net weight		Kg	15.5		16	
Sound power level	Hi~Lo	dB(A)	52/48/46/44/41/38/35		55/51/49/47/44/40/36	
Sound pressure level	Hi~Lo	dB(A)	39/36/34/32/29/26/23		44/40/38/36/33/29/25	
Volume of air treated	Hi~Lo	m ³ /h	500/430/410/370/330/280/250		600/520/480/440/400/360/280	
Outdoor unit specifications						
Dimensions	LxDxH	mm	732x330x555		802x350x555	
Net weight		Kg	24		27.5	
Sound power level		dB(A)	61		63	
Sound pressure level		dB(A)	51		53	
Volume of air treated	Max	m ³ /h	1950		2200	
Operating limits (outdoor temperature)	Cooling	°C			-15~43	
	Heating	°C			-22~24	
Optional parts						
Wi-Fi module	Included					
Individual wired control	M-RF-CW2-L-G / M-RF-CW3-L-G					

1. Value measured according to the harmonised standard EN14511. 2. EU Regulation No. 206/2012. - Value measured according to the harmonised standard EN14825. 3. EU Delegated Regulation No. 626/2011 on the new energy consumption labelling of air conditioners. 4. Refrigerant leakage contributes to climate change. When released into the atmosphere, refrigerants with a lower global warming potential (GWP) contribute less to global warming than those with a higher GWP. This appliance contains a refrigerant with a GWP of 675. Therefore, if 1 kg of this refrigerant were released into the atmosphere, the impact on global warming would be 675 times higher than 1 kg of CO₂ over a period of 100 years. Under no circumstances should the user attempt to intervene on the refrigerant circuit or disassemble the product. In case of need, always contact qualified personnel.

LIGHT COMMERCIAL MONOSPLIT R32

1-PHASE INDOOR UNITS

		kW	3.50	5.30	7.10
8-WAY COMPACT CASSETTE	 MTFGS-ZA		✓		
8-WAY BIG CASSETTE	 MTBGS-ZA			✓	✓
DUCTED	 MUDGS-ZA		✓	✓	✓
FLOOR/CEILING	 MSFGS-ZA		✓	✓	✓

OUTDOOR UNITS



3-PHASE INDOOR UNITS

		kW	10.00	14.00	16.00
8-WAY BIG CASSETTE	 MTBIS-ZA		✓	✓	✓
DUCTED	 MUCIS-ZA		✓	✓	✓
FLOOR/CEILING	 MSFIS-ZA		✓	✓	✓

OUTDOOR UNITS



8-WAY COMPACT CASSETTE 60x60

1 CAPACITY
3.50 kW

MEMORY FUNCTION

DOWN TO -20°C

CONDENSATE DRAIN PUMP INCLUDED maximum height difference **1000 mm** from panel edge

COMPACT DESIGN
260 mm height for recessed installation in false ceilings

WASHABLE FILTER
air quality optimization

UP TO 52°C
In cooling

CONTROLS
standard remote control

360° AIR DISTRIBUTION

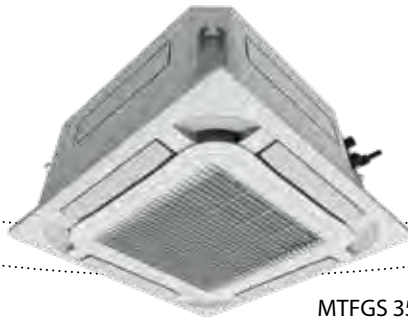
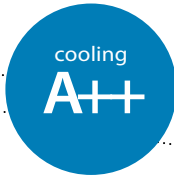

MTFGS 351 ZA

SEER **SCOP**
3.50 kW **7.10** **4.20**

Indoor unit model		MTFGS 351 ZA	
Outdoor unit model		MCKGS 351 ZA	
Type		DC-Inverter heat pump	
Control (supplied)		Remote control	
Nominal data			
Nominal capacity (T=+35°C)		kW	3.50
Nominal absorbed power (T=+35°C)	Cooling	kW	0.92
Nominal energy efficiency coefficient		EER ¹	3.80
Nominal capacity (T=+7°C)		kW	4.00
Nominal absorbed power (T=+7°C)	Heating	kW	1.00
Nominal energy performance coefficient		COP ¹	4.00
Seasonal data			
Theoretical load (P _{designc})		kW	3.50
Seasonal energy efficiency index	Cooling	SEER ²	7.10
Seasonal energy efficiency class		626/2011 ³	A++
Annual energy consumption		kWh/y	173
Theoretical load (P _{designh}) @ -10°C		kW	3.10
Seasonal performance coefficient	Heating	SCOP ²	4.20
Seasonal energy efficiency (η _s)	(average weather conditions)	%	165
Seasonal energy efficiency class		626/2011 ³	A+
Annual energy consumption		kWh/y	1033
Electrical data			
Power supply	Outdoor unit	Ph-V-Hz	1-220~240V-50/60HZ
Power cable		Type	3 x 1.5 mm ²
Connection wires between I.U. and O.U.		no.	4
Nominal absorbed current	Cooling	A	4.40
	Heating	A	4.80
Maximum current		A	6.00
Maximum absorbed power		kW	1.30
Refrigerant circuit data			
Refrigerant ⁴		Type (GWP)	R32 (675)
Q.ty of refrigerant pre-charge		Kg	0.57
Tons of CO ₂ equivalent		t	0.385
Liquid/gas refrigerant pipe diameter		mm (inches)	6.35(1/4) / 9.52(3/8)
Max split length		m	30
Max difference in height U.I./O.U.		m	15
Split length without additional charge		m	5
Additional charge		g/m	16
Indoor unit specifications			
Dimensions	LxDxH	mm	570x570x260
Net weight		Kg	16.5
Sound power level	SHi	dB(A)	47
Sound pressure level	SHi/Hi/Mi/Lo	dB(A)	36/35/33/29
Volume of air treated	SHi/Hi/Mi/Lo	m ³ /h	600/550/500/400
Outdoor unit specifications			
Dimensions	LxDxH	mm	675x285x553
Net weight		Kg	24.5
Sound power level	Max	dB(A)	56
Sound pressure level	Max	dB(A)	48
Volume of air treated	Max	m ³ /h	1800
Operating limits (outdoor temperature)	Cooling	°C	-20~-52
	Heating		-20~-24
Accessories			
Decorative panel		MTFPG 350 ZA	
Dimensions	LxDxH	mm	620x620x47.5
Net weight		Kg	3
Optional parts			
Wired control with Wi-Fi module integrated			DMW-ZA1 WiFi
Interface for connection to centralized control			DMC-LCAC-Gateway
Centralized controls			M-V-CC-T255-G2

1. Value measured according to the harmonized standard EN1451. 2. EU Regulation No. 206/2012. - Value measured according to the harmonized standard EN14825. 3. EU Delegated Regulation No. 626/2011 on the new labelling indicating the energy consumption of air conditioners. 4. Refrigerant leakage contributes to climate change. When released into the atmosphere, refrigerants with a lower global warming potential (GWP) contribute less to global warming than those with a higher GWP. This appliance contains a refrigerant with a GWP of 675. Therefore, if 1 kg of this refrigerant were released into the atmosphere, the impact on global warming would be 675 times higher than 1 kg of CO₂ over a period of 100 years. Under no circumstances should the user attempt to intervene on the refrigerant circuit or disassemble the product. If necessary, always contact qualified personnel. 5. DMC-LCAC-Gateway interface required.

8-WAY BIG CASSETTE 84x84

3 CAPACITIES
10.01~15.24 kW

-15~50°C in cooling
-20~24°C in heating

8-WAY PANEL, HOMOGENEOUS AND 360° AIR DELIVERY

PREPARATION FOR EXTERNAL AIR INLET

CONDENSATE DRAIN PUMP INCLUDED, with the possibility of raising the exhaust up to **750 mm** from the lower level

AUTO-RESTART CONTROLS
standard remote control

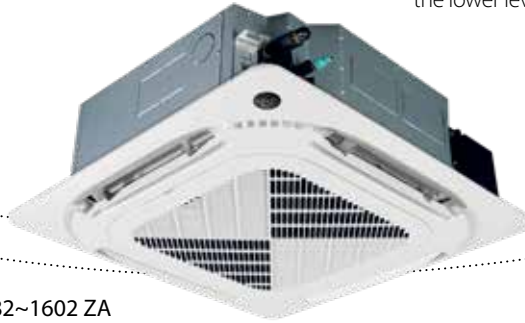
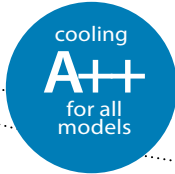

MTBIS 1082~1602 ZA

	SEER	SCOP
10.01 kW	6.30	4.00
11.72 kW	6.10	4.00
15.24 kW	6.10	4.00

Indoor unit model		MTBIS 1082 ZA		MTBIS 1402 ZA		MTBIS 1602 ZA		
Outdoor unit model		MCSIS 1082 ZA		MCSIS 1402 ZA		MCSIS 1602 ZA		
Type		DC-Inverter heat pump						
Control (supplied)		Remote control						
Nominal data								
Nominal capacity (T=+35°C)		kW	10.01 (2.70~11.43)	11.72 (3.52~15.83)	15.24 (4.10~16.12)			
Nominal absorbed power (T=+35°C)	Cooling	kW	3.04 (0.89~4.15)	3.62 (0.81~6.35)	5.70 (1.00~6.25)			
Nominal energy efficiency coefficient			EER ¹	3.29	3.24	2.67		
Nominal capacity (T=+7°C)		kW	11.14 (2.78~12.66)	14.07 (4.10~17.29)	18.17 (4.40~19.05)			
Nominal absorbed power (T=+7°C)	Heating	kW	3.00 (0.78~4.00)	3.75 (0.91~5.90)	5.70 (1.02~6.35)			
Nominal energy performance coefficient			COP ¹	3.71	3.75	3.19		
Seasonal data								
Theoretical load (Pdesignc)		kW	10.00	14.00	15.30			
Seasonal energy efficiency index	Cooling	SEER ²	6.30	6.10	6.10			
Seasonal energy efficiency class			626/2011 ³	A++	A++	A++		
Annual energy consumption			kWh/y	556	671	878		
Theoretical load (Pdesignh) @ -10°C		kW	8.20	11.20	11.80			
Seasonal performance coefficient	Heating (average weather conditions)	SCOP ²	4.00	4.00	4.00			
Seasonal energy efficiency (ηs)			%	157	157	157		
Seasonal energy efficiency class			626/2011 ³	A+	A+	A+		
Annual energy consumption		kWh/y	2870	3920	4130			
Electrical data								
Power supply	Outdoor unit	Ph-V-Hz	3Ph - 380/415V - 50Hz					
Power cable		Type	5 x 2.5 mm ²	5 x 4 mm ²	5 x 4 mm ²			
Connection wires between I.U. and O.U.		no.	4	4	4			
Nominal absorbed current	Cooling	A	6.50 (1.40~6.50)	5.60 (1.80~10.30)	8.80 (2.10~10.70)			
	Heating	A	5.00 (1.30~6.40)	5.70 (1.90~9.60)	8.80 (2.10~10.80)			
Maximum current		A	10.00	14.00	14.00			
Maximum absorbed power		kW	5.00	7.30	7.50			
Refrigerant circuit data								
Refrigerant ⁴		type (GWP)	R32 (675)	R32 (675)	R32 (675)			
Q.ty of refrigerant pre-charge		Kg	2.4	2.9	3.2			
Tons of CO2 equivalent		t	1.620	1.958	2.160			
Liquid/gas refrigerant pipe diameter		mm (inches)	9.52(3/8") / 15.88(5/8")					
Max split length		m	75	75	75			
Max difference in height U.I./O.U.		m	30	30	30			
Split length without additional charge		m	5	5	5			
Additional charge		g/m	24	24	24			
Indoor unit specifications								
Dimensions	LxDxH	mm	830x830x245	830x830x287	830x830x287			
Net weight		Kg	27.2	29.3	29.3			
Sound power level	Hi	dB(A)	63	66	66			
Sound pressure level	Hi/Mi/Lo/Silent	dB(A)	51/49/46/39	51.5/49/46.5/38.5	53/50.5/45.5/40			
Volume of air treated	Hi/Mi/Lo	m ³ /h	1700/1530/1300	1900/1750/1600	2000/1850/1650			
Diameter of the condensate drain pipe		mm	ø25	ø25	ø25			
Outdoor unit specifications								
Dimensions	LxDxH	mm	946x410x810	980x415x975	980x415x975			
Net weight		Kg	80.5	90	92			
Sound power level		dB(A)	70	73	75			
Sound pressure level		dB(A)	63	66	66			
Volume of air treated	Max	m ³ /h	4000	5600	5600			
Operating limits (outdoor temperature)	Cooling	°C	-15~50					
	Heating	°C	-20~24					
Accessories								
Decorative panel				MTBPI 1082 ZA				
Dimensions	LxDxH	mm	950x950x55	950x950x55	950x950x55			
Net weight		Kg	6	6	6			
Optional parts				DMW-WIFI-ZA				
Wired control with Wi-Fi module integrated								

1. Value measured according to the harmonised standard EN14511. 2. EU Regulation No. 206/2012 - N 2281/2016 - Value measured according to the harmonised standard EN14825. 3. EU Delegated Regulation No. 626/2011 on the new energy consumption labelling of air conditioners. 4. Refrigerant leakage contributes to climate change. When released into the atmosphere, refrigerants with a lower global warming potential (GWP) contribute less to global warming than those with a higher GWP. This appliance contains a refrigerant with a GWP of 675. Therefore, if 1 kg of this refrigerant were released into the atmosphere, the impact on global warming would be 675 times higher than 1 kg of CO2 over a period of 100 years. Under no circumstances should the user attempt to intervene on the refrigerant circuit or disassemble the product. In case of need, always contact qualified personnel.

DUCTED

3 CAPACITIES

3.50~7.10 kW

WASHABLE FILTER

air quality optimization

MEMORY FUNCTION

CONDENSATE DRAIN PUMP INCLUDED

maximum height difference **1000 mm** from lower profile

MAXIMUM COMPACTNESS

only **200 mm** high for the 3.50 and 5.30 kW models

MAXIMUM SPLITTING LENGTH 30 m

STATIC PRESSURE LEVEL

adjustable up to **160 Pa** (mod. 7.10 kW)

COMPATIBLE WITH SYSTEMS



DOWN TO -20°C

CONTROLS

wired control included

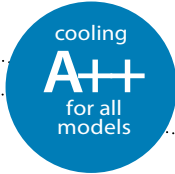

Wi-Fi optional
Wired Control
DMW-ZA1 WiFi

	SEER	SCOP
3.50 kW	6.50	4.00
5.30 kW	6.30	4.00
7.10 kW	6.60	4.10

MUDGS 351~531 ZA

MVDGS 711 ZA

Indoor unit model		MUDGS 351 ZA		MUDGS 531 ZA		MVDGS 711 ZA	
Outdoor unit model		MCKGS 351 ZA		MCKGS 531 ZA		MCKGS 711 ZA	
Type		DC-Inverter heat pump					
Control (supplied)		Wired control					
Nominal data							
Nominal capacity (T=+35°C)		kW	3.50	5.30	7.10		
Nominal absorbed power (T=+35°C)	Cooling	kW	1.03	1.51	1.92		
Nominal energy efficiency coefficient		EER ¹	3.40	3.50	3.70		
Nominal capacity (T=+7°C)		kW	4.00	5.60	8.00		
Nominal absorbed power (T=+7°C)	Heating	kW	1.00	1.42	2.00		
Nominal energy performance coefficient		COP ¹	4.00	3.95	4.00		
Seasonal data							
Theoretical load (Pdesignc)	Cooling	kW	3.50	5.30	7.10		
Seasonal energy efficiency index		SEER ²	6.50	6.30	6.60		
Seasonal energy efficiency class		626/2011 ³	A++	A++	A++		
Annual energy consumption		kWh/y	188	294	377		
Theoretical load (Pdesignh) @ -10°C	Heating (average weather conditions)	kW	3.00	3.90	4.70		
Seasonal performance coefficient		SCOP ²	4.00	4.00	4.10		
Seasonal energy efficiency (ηs)		%	157	157	161		
Seasonal energy efficiency class		626/2011 ³	A+	A+	A+		
Annual energy consumption		kWh/y	1050	1365	1605		
Electrical data							
Power supply	Outdoor unit	Ph-V-Hz	1-220~240V-50/60HZ				
Power cable		Type	3 x 1.5 mm ²	3 x 2.5 mm ²	3 x 4 mm ²		
Connection wires between I.U. and O.U.		no.	4	4	4		
Nominal absorbed current	Cooling Heating	A	4.90	7.20	9.20		
		A	4.80	6.80	9.60		
Maximum current		A	6.00	9.50	14.00		
Maximum absorbed power		kW	1.30	1.90	2.80		
Refrigerant circuit data							
Refrigerant ⁴		Type (GWP)	R32 (675)	R32 (675)	R32 (675)		
Q.ty of refrigerant pre-charge		kg	0.57	0.85	1.5		
Tons of CO2 equivalent		t	0.385	0.574	1.013		
Liquid/gas refrigerant pipe diameter		mm (inches)	6.35(1/4) / 9.52(3/8)	6.35(1/4) / 12.74(1/2)	9.52(3/8) / 15.88(5/8)		
Max split length		m	30	30	30		
Max difference in height U.I./O.U.		m	15	20	20		
Split length without additional charge		m	5	5	5		
Additional charge		g/m	16	16	20		
Indoor unit specifications							
Dimensions	LxDxH	mm	700x450x200	1000x450x200	900x655x260		
Net weight		kg	18	24	29.5		
Sound power level	SHi	dB(A)	56	59	58		
Sound pressure level	SHi/Hi/Mi/Lo	dB(A)	35/33/32/30	36/35/33/31	37/35/33/31		
Volume of air treated	SHi/Hi/Mi/Lo	m ³ /h	600/550/500/400	900/800/700/600	1100/1000/900/800		
Fan's static pressure	Std/Max	Pa	25/80	25/80	25/160		
Outdoor unit specifications							
Dimensions	LxDxH	mm	675x285x553	745x300x555	889x340x660		
Net weight		kg	24.5	30.5	41.5		
Sound power level	Max	dB(A)	56	65	69		
Sound pressure level	Max	dB(A)	48	52	55		
Volume of air treated	Max	m ³ /h	1800	2200	3600		
Operating limits (outdoor temperature)	Cooling	°C		-20~52			
	Heating	°C		-20~24			
Optional parts							
Wired control with Wi-Fi module integrated				DMW-ZA1 WiFi			
Interface for connection to centralized control				DMC-LCAC-Gateway			
Centralized control ⁵				M-V-CC-T255-G2			

1. Value measured according to the harmonized standard EN1451. 2. EU Regulation No. 206/2012 -- Value measured according to the harmonized standard EN14825. 3. EU Delegated Regulation No. 626/2011 on the new labelling indicating the energy consumption of air conditioners. 4. Refrigerant leakage contributes to climate change. When released into the atmosphere, refrigerants with a lower global warming potential (GWP) contribute less to global warming than those with a higher GWP. This appliance contains a refrigerant with a GWP of 675. Therefore, if 1 kg of this refrigerant were released into the atmosphere, the impact on global warming would be 675 times higher than 1 kg of CO2, over a period of 100 years. Under no circumstances should the user attempt to intervene on the refrigerant circuit or disassemble the product. If necessary, always contact qualified personnel. 5. DMC-LCAC-Gateway interface required.

DUCTED

3 CAPACITIES

9.20~15.24 kW

-15~50°C in cooling
-20~24°C in heating

CONDENSATE DRAIN PUMP INCLUDED

DOUBLE INSTALLATION POSSIBILITY:

ceiling or wall recessed

AUTO-RESTART

WEEKLY TIMER

CONTROLS

wired control included

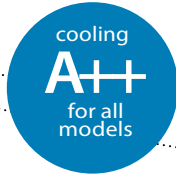

MUCIS 1082~1602 ZA

	SEER	SCOP
9.20 kW	6.10	4.00
12.40 kW	6.10	4.00
15.24 kW	6.10	4.00

Indoor unit model		MUCIS 1082 ZA		MUCIS 1402 ZA		MUCIS 1602 ZA	
Outdoor unit model		MCSIS 1082 ZA		MCSIS 1402 ZA		MCSIS 1602 ZA	
Type		DC-Inverter heat pump					
Control (supplied)		Wired control					
Nominal data							
Nominal capacity (T=+35°C)	Cooling	kW	9.20 (2.73~11.73)	12.40 (3.52~15.83)	15.24 (4.10~17.29)		
Nominal absorbed power (T=+35°C)		kW	2.83 (0.89~4.20)	3.83 (0.81~6.45)	5.25 (1.03~6.65)		
Nominal energy efficiency coefficient		EER ¹	3.25	3.24	2.90		
Nominal capacity (T=+7°C)	Heating	kW	10.10 (2.78~12.84)	15.24 (4.11~17.59)	17.58 (4.40~20.52)		
Nominal absorbed power (T=+7°C)		kW	2.71 (0.78~4.00)	4.10 (0.95~5.80)	4.74 (0.95~6.60)		
Nominal energy performance coefficient		COP ¹	3.75	3.72	3.71		
Seasonal data							
Theoretical load (Pdesignc)	Cooling	kW	9.20	12.40	15.30		
Seasonal energy efficiency index		SEER ²	6.10	6.10	6.10		
Seasonal energy efficiency class		626/2011 ³	A++	A++	A++		
Annual energy consumption		kWh/y	528	711	878		
Theoretical load (Pdesignh) @ -10°C	Heating (average weather conditions)	kW	8.80	11.50	12.50		
Seasonal performance coefficient		SCOP ²	4.00	4.00	4.00		
Seasonal energy efficiency (ηs)		%	157	157	157		
Seasonal energy efficiency class		626/2011 ³	A+	A+	A+		
Annual energy consumption		kWh/y	3080	4025	4375		
Electrical data							
Power supply	Outdoor unit	Ph-V-Hz	3Ph - 380/415V - 50Hz				
Power cable		type	5 x 2.5 mm ²	5 x 4 mm ²	5 x 4 mm ²		
Connection wires between I.U. and O.U.		no.	4	4	4		
Nominal absorbed current	Cooling	A	4.40 (1.40~6.70)	6.00 (1.80~10.50)	8.10 (3.10~11.50)		
	Heating	A	4.30 (1.30~6.40)	7.10 (2.00~9.00)	7.40 (2.00~11.50)		
Maximum current		A	10.00	14.00	14.00		
Maximum absorbed power		kW	5.00	7.30	7.50		
Refrigerant circuit data							
Refrigerant ⁴		type (GWP)	R32 (675)		R32 (675)		R32 (675)
Q.ty of refrigerant pre-charge		Kg	2.4	2.9	3.2		
Tons of CO2 equivalent		t	1.620	1.958	2.160		
Liquid/gas refrigerant pipe diameter		mm (inches)	9.52(3/8") / 15.88(5/8")				
Max split length		m	75	75	75		
Max difference in height U.I./O.U.		m	30	30	30		
Split length without additional charge		m	5	5	5		
Additional charge		g/m	24	24	24		
Indoor unit specifications							
Dimensions	LxDxH	mm	1200x750x245	1200x750x245	1200x750x300		
Net weight		Kg	38.4	40.4	42.9		
Sound power level	Hi	dB(A)	62	65	66		
Sound pressure level	Hi/Mi/Lo/Silent	dB(A)	39/37/34/29	43.5/41.5/39.5/36	44.5/43/41.5/38		
Volume of air treated	Hi/Mi/Lo	m ³ /h	1700/1400/1100	2000/1700/1300	2200/1900/1500		
Fan's static pressure	Std/Max	Pa	37/160	50/160	50/160		
Diameter of the condensate drain pipe		mm	ø25	ø25	ø25		
Outdoor unit specifications							
Dimensions	LxDxH	mm	946x410x810	980x415x975	980x415x975		
Net weight		Kg	80.5	90	92		
Sound power level		dB(A)	70	73	75		
Sound pressure level		dB(A)	63	66	66		
Volume of air treated	Max	m ³ /h	4000	5600	5600		
Operating limits (outdoor temperature)	Cooling	°C	-15~50				
	Heating		-20~24				
Optional parts							
Wired control with Wi-Fi module integrated				DMW-WIFI-ZA			

1. Value measured according to the harmonized standard EN1451. 2. EU Regulation No. 206/2012 - N2281/2016 - Value measured according to the harmonized standard EN14825. 3. EU Delegated Regulation No. 626/2011 on the new labelling indicating the energy consumption of air conditioners. 4. Refrigerant leakage contributes to climate change. When released into the atmosphere, refrigerants with a lower global warming potential (GWP) contribute less to global warming than those with a higher GWP. This appliance contains a refrigerant with a GWP of 675. Therefore, if 1 kg of this refrigerant were released into the atmosphere, the impact on global warming would be 675 times higher than 1 kg of CO2, over a period of 100 years. Under no circumstances should the user attempt to intervene on the refrigerant circuit or disassemble the product. If necessary, always contact qualified personnel.

FLOOR/CEILING

3 CAPACITIES

3.50~7.10 kW

COMPACT DESIGN

235 mm height for all models

WASHABLE FILTER

air quality optimization

SELF-DIAGNOSIS CHECK CONTROL

MEMORY FUNCTION

DAILY TIMER

MAXIMUM SPLITTING LENGTH 30 m

DOWN TO -20°C

CONTROLS

remote control included

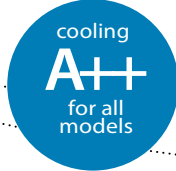

MSFGS 351~711 ZA



	SEER	SCOP
3.50 kW	7.20	4.10
5.30 kW	6.50	4.20
7.10 kW	7.20	4.30

Indoor unit model	MSFGS 351 ZA		MSFGS 531 ZA		MSFGS 711 ZA	
Outdoor unit model	MCKGS 351 ZA		MCKGS 531 ZA		MCKGS 711 ZA	
Type	DC-Inverter heat pump					
Control (supplied)	Remote control					
Nominal data						
Nominal capacity (T=+35°C)	Cooling	kW	3.50	5.30	7.10	
Nominal absorbed power (T=+35°C)		kW	0.92	1.56	2.03	
Nominal energy efficiency coefficient		EER ¹	3.80	3.40	3.50	
Nominal capacity (T=+7°C)	Heating	kW	4.00	5.60	7.70	
Nominal absorbed power (T=+7°C)		kW	0.93	1.44	1.95	
Nominal energy performance coefficient		COP ¹	4.30	3.90	3.95	
Seasonal data						
Theoretical load (Pdesignc)	Cooling	kW	3.50	5.30	7.10	
Seasonal energy efficiency index		SEER ²	7.20	6.50	7.20	
Seasonal energy efficiency class		626/2011 ³	A++	A++	A++	
Annual energy consumption		kWh/y	170	285	345	
Theoretical load (Pdesignh) @ -10°C	Heating (average weather conditions)	kW	3.10	3.90	4.70	
Seasonal performance coefficient		SCOP ²	4.10	4.20	4.30	
Seasonal energy efficiency (ηs)		%	161	165	169	
Seasonal energy efficiency class		626/2011 ³	A+	A+	A+	
Annual energy consumption		kWh/y	1059	1300	1530	
Electrical data						
Power supply	Outdoor unit	Ph-V-Hz	1-220~240V-50/60Hz			
Power cable		Type	3 x 1.5 mm ²	3 x 2.5 mm ²	3 x 4 mm ²	
Connection wires between I.U. and O.U.		no.	4	4	4	
Nominal absorbed current	Cooling	A	4.40	7.30	9.70	
	Heating	A	4.50	7.00	9.10	
Maximum current		A	6.00	9.50	14.00	
Maximum absorbed power		kW	1.30	1.90	2.80	
Refrigerant circuit data						
Refrigerant ⁴	Type (GWP)	R32 (675)		R32 (675)		
Q.ty of refrigerant pre-charge	Kg	0.57	0.85	1.5		
Tons of CO ₂ equivalent	t	0.385	0.574	1.013		
Liquid/gas refrigerant pipe diameter	mm (inches)	6.35(1/4) / 9.52(3/8)		6.35(1/4) / 12.74(1/2)		
Max split length	m	30	30	30		
Max difference in height U.I./O.U.	m	15	20	20		
Split length without additional charge	m	5	5	5		
Additional charge	g/m	16	16	20		
Indoor unit specifications						
Dimensions	LxDxH	mm	870x665x235	870x665x235	1200x665x235	
Net weight		Kg	24	25	31	
Sound power level	SHi	dB(A)	49	59	54	
Sound pressure level	SHi/Hi/Mi/Lo	dB(A)	35/34/31/28	41/40/38/36	41/39/37/35	
Volume of air treated	SHi/Hi/Mi/Lo	m ³ /h	650/600/500/400	900/800/700/600	1250/1100/1000/900	
Outdoor unit specifications						
Dimensions	LxDxH	mm	675x285x553	745x300x555	889x340x660	
Net weight		Kg	24.5	30.5	41.5	
Sound power level	Max	dB(A)	56	65	69	
Sound pressure level	Max	dB(A)	48	52	55	
Volume of air treated	Max	m ³ /h	1800	2200	3600	
Operating limits (outdoor temperature)	Cooling	°C	-20~-52			
	Heating		-20~-24			
Optional parts						
Wired control with Wi-Fi module integrated				DMW-ZA1 WiFi		
Interface for connection to centralized control				DMC-LCAC-Gateway		
Centralized control ⁵				M-V-CC-T255-G2		

1. Value measured according to the harmonized standard EN1451. 2. EU Regulation No. 206/2012 - Value measured according to the harmonized standard EN14825. 3. EU Delegated Regulation No. 626/2011 on the new labelling indicating the energy consumption of air conditioners. 4. Refrigerant leakage contributes to climate change. When released into the atmosphere, refrigerants with a lower global warming potential (GWP) contribute less to global warming than those with a higher GWP. This appliance contains a refrigerant with a GWP of 675. Therefore, if 1 kg of this refrigerant were released into the atmosphere, the impact on global warming would be 675 times higher than 1 kg of CO₂ over a period of 100 years. Under no circumstances should the user attempt to intervene on the refrigerant circuit or disassemble the product. If necessary, always contact qualified personnel. 5. DMC-LCAC-Gateway interface required.

FLOOR/CEILING

3 CAPACITIES
10.10~12.30 kW

-15~50°C in cooling
-20~24°C in heating

DOUBLE INSTALLATION POSSIBILITY

TURBO FUNCTION, to heat and cool the environment quickly

WIDE AIR DISTRIBUTION GRILLE
with aerodynamic fins to ensure rapid operation and reduce noise levels

CONTROLS
standard remote control

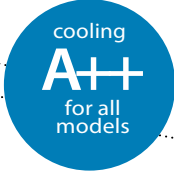













MSFIS 1082~1602 ZA

	SEER	SCOP
10.10 kW	6.20	4.00
12.10 kW	6.10	4.00
12.30 kW	6.10	4.00

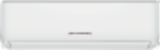
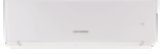
Indoor unit model		MSFIS 1082 ZA		MSFIS 1402 ZA		MSFIS 1602 ZA	
Outdoor unit model		MCSIS 1082 ZA		MCSIS 1402 ZA		MCSIS 1602 ZA	
Type		DC-Inverter heat pump					
Control (supplied)		Remote control					
Nominal data							
Nominal capacity (T=+35°C)		kW		10.10 (2.73~11.78)		12.10 (3.52~15.24)	
Nominal absorbed power (T=+35°C)		kW		3.10 (0.89~4.30)		3.73 (0.91~6.20)	
Nominal energy efficiency coefficient		EER ¹		3.26		3.25	
Nominal capacity (T=+7°C)		kW		11.71 (2.81~12.78)		12.90 (4.10~17.59)	
Nominal absorbed power (T=+7°C)		kW		3.14 (0.78~3.95)		3.47 (0.95~5.95)	
Nominal energy performance coefficient		COP ¹		3.73		3.72	
Seasonal data							
Theoretical load (Pdesignc)		kW		10.10		12.10	
Seasonal energy efficiency index		SEER ²		6.20		6.10	
Seasonal energy efficiency class		626/2011 ³		A++		A++	
Annual energy consumption		kWh/y		570		694	
Theoretical load (Pdesignh) @ -10°C		kW		8.60		11.20	
Seasonal performance coefficient		SCOP ²		4.00		4.00	
Seasonal energy efficiency (ηs)		%		157		157	
Seasonal energy efficiency class		626/2011 ³		A+		A+	
Annual energy consumption		kWh/y		3150		4025	
Electrical data							
Power supply		Outdoor unit		Ph-V-Hz		3Ph - 380/415V - 50Hz	
Power cable		type		5 x 2.5 mm ²		5 x 4 mm ²	
Connection wires between I.U. and O.U.		no.		4		4	
Nominal absorbed current		Cooling		A		6.30 (1.40~6.80)	
		Heating		A		5.50 (1.30~6.20)	
Maximum current		A		10.00		14.00	
Maximum absorbed power		kW		5.00		7.30	
Refrigerant circuit data							
Refrigerant ⁴		type (GWP)		R32 (675)		R32 (675)	
Q.ty of refrigerant pre-charge		Kg		2.4		2.9	
Tons of CO2 equivalent		t		1.620		1.958	
Liquid/gas refrigerant pipe diameter		mm (inches)		9.52(3/8") / 15.88(5/8")			
Max split length		m		75		75	
Max difference in height U.I./O.U.		m		30		30	
Split length without additional charge		m		5		5	
Additional charge		g/m		24		24	
Indoor unit specifications							
Dimensions		LxDxH		mm		1650x675x235	
Net weight		Kg		41.5		41.7	
Sound power level		Hi		dB(A)		64	
Sound pressure level		Hi/Mi/Lo/Silent		dB(A)		51/47.5/45/37	
Volume of air treated		Hi/Mi/Lo		m ³ /h		1955/1728/1504	
Diameter of the condensate drain pipe		mm		Ø25		Ø25	
Outdoor unit specifications							
Dimensions		LxDxH		mm		946x410x810	
Net weight		Kg		80.5		90	
Sound power level		dB(A)		70		73	
Sound pressure level		dB(A)		63		66	
Volume of air treated		Max		m ³ /h		4000	
Operating limits (outdoor temperature)		Cooling		°C		-15~-50	
		Heating		°C		-20~-24	
Optional parts							
Wired control with Wi-Fi module integrated		DMW-WIFI-ZA					

1. Value measured according to the harmonized standard EN1451. 2. EU Regulation No. 206/2012 - N.2281/2016 - Value measured according to the harmonized standard EN14825. 3. EU Delegated Regulation No. 626/2011 on the new labelling indicating the energy consumption of air conditioners. 4. Refrigerant leakage contributes to climate change. When released into the atmosphere, refrigerants with a lower global warming potential (GWP) contribute less to global warming than those with a higher GWP. This appliance contains a refrigerant with a GWP of 675. Therefore, if 1 kg of this refrigerant were released into the atmosphere, the impact on global warming would be 675 times higher than 1 kg of CO2, over a period of 100 years. Under no circumstances should the user attempt to intervene on the refrigerant circuit or disassemble the product. If necessary, always contact qualified personnel.

RESIDENTIAL & LIGHT COMMERCIAL MULTISPLIT R32

kW		4.10	5.30	6.10	7.10	8.00	12.10
No. of connectable indoor units		1-2	1-2	2-3	2-3	2-4	2-5
		 MCKGM 402 Z2	 MCKGM 532 Z2	 MCKGM 602 Z3	 MCKGM 712 Z3	 MCKGM 822 Z4	 MCKGM 1202 Z5
ACTION 	MKEGM 267 ZAL	✓	✓	✓	✓	✓	✓
	MKEGM 357 ZAL	✓	✓	✓	✓	✓	✓
	MKEGM 537 ZAL			✓	✓	✓	✓
	MKEGM 717 ZAL				✓	✓	✓
AIRPRO PLUS 	MKEGM 265 ZAL	✓	✓	✓	✓	✓	✓
	MKEGM 355 ZAL	✓	✓	✓	✓	✓	✓
	MKEGM 535 ZAL			✓	✓	✓	✓
	MKEGM 715 ZAL				✓	✓	✓
CONSOLE 	MFIGM 261 ZAL	✓	✓	✓	✓	✓	✓
	MFIGM 351 ZAL	✓	✓	✓	✓	✓	✓
	MFIGM 531 ZAL			✓	✓	✓	✓
COMPACT CASSETTE 	MTFGM 351 ZL	✓	✓	✓	✓	✓	✓
	MTFGM 531 ZL			✓	✓	✓	✓
1-WAY CASSETTE 	MTSGM 351 ZL	✓	✓	✓	✓	✓	✓
	MTSGM 531 ZL			✓	✓	✓	✓
DUCTED 	MUCGM 261 ZL	✓	✓	✓	✓	✓	✓
	MUCGM 351 ZL	✓	✓	✓	✓	✓	✓
	MUCGM 531 ZL			✓	✓	✓	✓
FLOOR/CEILING 	MSEGM 260 ZL	✓	✓	✓	✓	✓	✓
	MSEGM 350 ZL	✓	✓	✓	✓	✓	✓
	MSEGM 530 ZL			✓	✓	✓	✓

MULTISPLIT OUTDOOR UNITS

Multiwarm has a wide range of outdoor units, with different power motors. Multisplit outdoor units can be connected up to 5 indoor units, for residential and commercial use.

Equipped with a DC Inverter rotary compressor, they guarantee the best performance in all seasons.



Outdoor unit	EER*	COP*	SEER*	SCOP*
MCKGM 402 Z2	3.72	4.54	7.20 / A++	4.20 / A+
MCKGM 532 Z2	3.58	4.53	7.20 / A++	4.20 / A+
MCKGM 602 Z3	4.12	4.56	7.80 / A++	4.30 / A+
MCKGM 712 Z3	3.77	3.86	7.10 / A++	4.30 / A+
MCKGM 822 Z4	3.77	4.31	7.20 / A++	4.20 / A+
MCKGM 1202 Z5	3.56	4.08	7.20 / A++	4.20 / A+

* The values reported may vary depending on the combinations chosen. For more information, refer to the technical manuals.

-15°C
High heating operating efficiency

43°C
High cooling operating efficiency

High compactness



Top-level performance and efficiency for the 12.1 kW capacity

Multiwarm offers a complete range of indoor units - from wall-mounted units to cassettes, right through to ducted units - ensuring the best solution for end-user needs.

The key figures for the 12.1 kW size (efficiency, maximum piping length, delivered output) are among the best in its market segment.

12.1 kW

High-capacity size with up to 5 connections



TOP

2.6 kW

Maximum modulation in cooling

TOP

15.2 kW

Maximum delivered output in cooling

TOP

3.0 kW

Maximum modulation in heating

Silver

15.5 kW

Maximum delivered output in heating

A lower minimum value in the modulation range means the system operates at low output when demand is limited, delivering higher efficiency and lower consumption.

A higher maximum value in the modulation range, under high demand, ensures the system can go beyond nominal operation when outdoor temperatures allow.

Output will drop, but the user's thermal comfort will still be maintained.

TOP

7.2 SEER

Highest SEER in its market segment

TOP

A++

Cooling energy class

TOP

100 m

Best maximum piping length in its market bracket

TOP

4.2 SCOP

Highest SCOP in its market segment

TOP

A+

Heating energy class

The values shown are the result of an internal comparative analysis with the main competitors in the relevant market segment. Values updated in September 2025 based on data in the 2025 public catalogues.

Ask your sales representative for more information.

KEY



Top feature, the best data on the market



Silver feature, one of the best figures on the market

OUTDOOR UNITS

6 CAPACITIES

4.10~12.10 kW

UP TO FIVE CONNECTABLE INDOOR UNITS

MAXIMUM FLEXIBILITY

ease of installation guaranteed by wide ranges of refrigerant piping splitting

ALL COMPRESSORS ARE ROTARY DC INVERTER

WIDE OPERATION RANGE

heating with outdoor temperatures down to -15° C



MCKGM 402 Z2 / MCKGM 532 Z2



MCKGM 602 Z3 / MCKGM 712 Z3 / MCKGM 822 Z4



MCKGM 1202 Z5









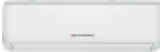

Outdoor unit model		MCKGM 402 Z2	MCKGM 532 Z2	MCKGM 602 Z3	MCKGM 712 Z3	MCKGM 822 Z4	MCKGM 1202 Z5		
Type		DC-Inverter heat pump outdoor unit							
Connectable indoor units (min - max)		no.	1-2	1-2	2-3	2-3	2-4		
Nominal data									
Nominal capacity (T=+35°C)	Cooling	kW	4.10 (2.05~5.00)	5.30 (2.14~5.80)	6.10 (2.22~8.30)	7.10 (2.30~9.20)	8.00 (2.30~11.00)	12.10 (2.60~15.20)	
		Nominal absorbed power (T=+35°C)	1.10	1.48	1.48	1.88	2.12	3.40	
		Nominal energy efficiency coefficient	EER ¹	3.72	3.58	4.12	3.77	3.77	3.56
Nominal capacity (T=+7°C)	Heating	kW	4.40 (2.49~5.40)	5.65 (2.58~6.50)	6.50 (3.60~8.50)	8.60 (3.65~9.20)	9.50 (3.65~10.25)	13.00 (3.00~15.50)	
		Nominal absorbed power (T=+7°C)	0.97	1.25	1.43	2.23	2.20	3.19	
		Nominal energy performance coefficient	COP ¹	4.54	4.53	4.56	3.86	4.31	4.08
Seasonal data									
Theoretical load (Pdesignc)	Cooling	kW	4.10	5.30	6.10	7.10	8.00	12.10	
		SEER ²	7.20	7.20	7.80	7.10	7.20	7.20	
		626/2011 ³	A++	A++	A++	A++	A++	A++	
Annual energy consumption		kWh/y	199	257	273	350	388	588	
Theoretical load (Pdesignh) @ -10°C	Heating (average weather conditions)	kW	3.80	4.10	6.10	6.10	7.20	13.00	
		Seasonal energy efficiency index	SCOP ²	4.20	4.20	4.30	4.30	4.20	4.20
		Seasonal energy efficiency class	626/2011 ³	A+	A+	A+	A+	A+	A+
Annual energy consumption		kWh/y	1266	1366	1986	1986	2400	4333	
Electrical data									
Power supply	Ph-V-Hz	1-220~240V-50HZ							
Power cable	Type	3 x 2.5 mm ²	3 x 2.5 mm ²	3 x 4 mm ²	3 x 4 mm ²	3 x 4 mm ²	3 x 4 mm ²		
Connection wires between each I.U. and O.U.	no.	4	4	4	4	4	4		
Nominal absorbed current	Cooling	A	4.90	6.60	6.60	8.40	9.40	15.10	
	Heating	A	4.40	5.60	6.30	9.90	9.80	14.20	
Maximum current	A	10.00	11.00	12.90	15.00	16.00	21.70		
Maximum absorbed power	kW	2.25	2.50	2.90	3.40	3.60	5.00		
Refrigerant circuit data									
Refrigerant ⁴	Type (GWP)	R32 (675)							
Q.ty of refrigerant pre-charge	kg	0.75	0.90	1.60	1.70	1.80	2.40		
Tons of CO2 equivalent	t	0.506	0.608	1.080	1.148	1.215	1.620		
Liquid/gas refrigerant pipe diameter	mm (inches)	2 x 6.35(1/4)	2 x 6.35(1/4)	3 x 6.35(1/4)	3 x 6.35(1/4)	4 x 6.35(1/4)	5 x 6.35(1/4)		
		2 x 9.52(3/8)	2 x 9.52(3/8)	3 x 9.52(3/8)	3 x 9.52(3/8)	4 x 9.52(3/8)	5 x 9.52(3/8)		
Total split length	m	40	40	60	60	70	100		
Max length of a single refrigerant line	m	20	20	20	20	20	25		
Max difference in height I.U./O.U.	m	15	15	15	15	15	25		
Max difference in height between I.U.	m	15	15	15	15	15	25		
Split length without additional charge	m	10	10	30	30	40	50		
Additional charge	g/m	20	20	20	20	20	20		
Product specifications									
Dimensions	LxDxH	mm	745x300x550	745x300x550	889x340x654	889x340x654	889x340x654	1020x427x826	
Net weight	kg	30	32	47.5	47.5	51	73		
Sound power level	Max	dB(A)	62	64	68	68	68	74	
Sound pressure level	Max	dB(A)	52	54	58	58	58	60	
Volume of air treated	m ³ /h	2300	2300	3800	3800	3800	5800		
Operating limits (outdoor temperature)	Cooling	°C						-15~43	
	Heating	°C						-15~24	

Seasonal energy efficiency values refer to the following combinations:

MCKGM 402 Z2 + 2 x MKEGM 265 ZAL; MCKGM 532 Z2 + 2 x MKEGM 265 ZAL; MCKGM 602 Z3 + 3x MKEGM 265Z AL; MCKGM 712 Z3 + 3 x MKEGM 265 ZAL; MCKGM 822 Z4 + 4 x MKEGM 265 ZAL; MCKGM 1202 Z5 + 5 x MKEGM 265 ZAL.

1. Value measured according to the harmonized standard EN14511. 2. EU Regulation No. 206/201 - N.2281/2016 - Value measured according to the harmonized standard EN14825. 3. EU Delegated Regulation No. 626/2011 on the new labelling indicating the energy consumption of air conditioners. 4. Refrigerant leakage contributes to climate change. When released into the atmosphere, refrigerants with a lower global warming potential (GWP) contribute less to global warming than those with a higher GWP. This appliance contains a refrigerant with a GWP of 675. Therefore, if 1 kg of this refrigerant were released into the atmosphere, the impact on global warming would be 675 times higher than 1 kg of CO2, over a period of 100 years. Under no circumstances should the user attempt to intervene on the refrigerant circuit or disassemble the product. In case of need, always contact qualified personnel.

MULTIOMNIA DHW HEAT RECOVERY R32

		kW	10.6	12.1
No. of connectable indoor units without tank			2-3	2-4
No. of connectable indoor units in addition to the tank			1-3	1-4
			 	 
			MCKGWM 1002 Z3W	MCKGWM 1202 Z4W
ACTION	MKEGM 267 ZAL		✓	✓
	MKEGM 357 ZAL		✓	✓
	MKEGM 537 ZAL		✓	✓
	MKEGM 717 ZAL		✓	✓
AIRPRO PLUS	MKEGM 265 ZAL		✓	✓
	MKEGM 355 ZAL		✓	✓
	MKEGM 535 ZAL		✓	✓
	MKEGM 715 ZAL		✓	✓
CONSOLE	MFIGM 261 ZAL		✓	✓
	MFIGM 351 ZAL		✓	✓
	MFIGM 531 ZAL		✓	✓
COMPACT CASSETTE	MTFGM 351 ZL		✓	✓
	MTFGM 531 ZL		✓	✓
1-WAY CASSETTE	MTSGM 351 ZL		✓	✓
	MTSGM 531 ZL		✓	✓
DUCTED	MUCGM 261 ZL		✓	✓
	MUCGM 351 ZL		✓	✓
	MUCGM 531 ZL		✓	✓
FLOOR/CEILING	MSEGM 260 ZL		✓	✓
	MSEGM 350 ZL		✓	✓
	MSEGM 530 ZL		✓	✓
TANK DHW 185L	 MWTGM 200 Z4W		✓	✓
				

Multiomnia

Outdoor units DHW

NEW

The Multiwarm Multisplit range is expanding, with two outdoor units that can be connected to both standard indoor units and a 185 L tank for DHW production.

Residential heating, cooling and DHW production with a single outdoor unit.

Ability to produce DHW free of charge during the summer thanks to **heat recovery** while the air-to-air indoor units are operating in cooling mode.

<p>-22°C</p> <p>Wide operating range in heating</p>	<p>43°C</p> <p>Wide operating range in cooling</p>	<p>-22°C</p> <p>Wide operating range in DHW production</p>
<p>185L</p> <p>Tank capacity</p>	<p>A++</p> <p>Cooling energy class</p>	<p>up to 80°C</p> <p>DHW using the electric heater</p>



DMW WTGM



MCKGWM 1002 Z3W MCKGWM 1202 Z4W



MWTGM 200 Z4W

MultiOmnia



What it is and how it works

- Dedicated MCKGWM-ZW outdoor units with connections for standard indoor units plus a **dedicated connection for the DHW tank**.
- Ability to manage cooling and heating with standard direct-expansion (DX) units, and to heat domestic hot water via the tank - all with a **single refrigeration circuit and a single outdoor unit**.
- The DX indoor units are the same as the standard multisplit range, offering maximum flexibility for compatibility and connectivity.

Multisplit + DHW MULTIOMNIA Heating + DHW

Space heating via DX units and domestic **hot water heating** take place **simultaneously**. The outdoor unit distributes available capacity between the indoor units and the tank, as in a standard multisplit system.

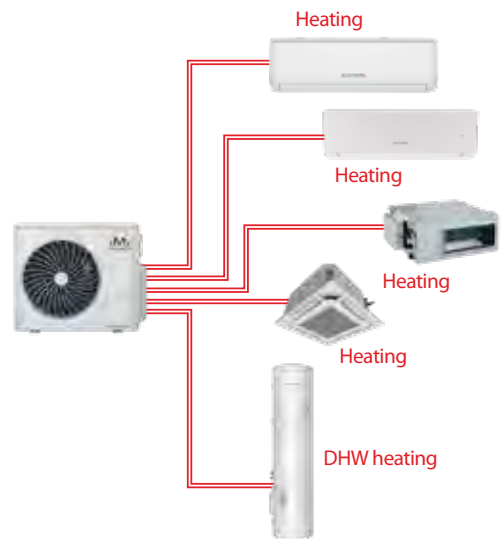

Multisplit + DHW MULTIOMNIA Cooling + DHW > Heat recovery

- While the DX indoor units operate in cooling mode, the refrigerant gas that would normally reject heat to the atmosphere via the outdoor unit is also diverted to the tank, reusing that heat to heat domestic hot water at no cost.
- Thanks solely to free heat recovery, the tank temperature can typically reach an average of 45°C.
- In summer operation, almost all DHW demand will be met **FREE OF CHARGE**.

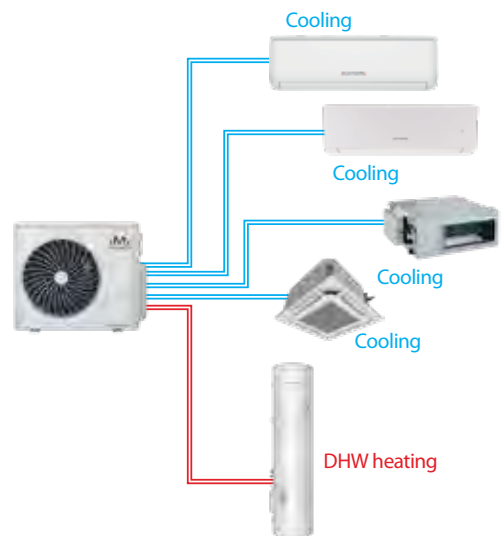

MultiOmnia



Outdoor units Multisplit + DHW

Free DHW during cooling operation of the DX units thanks to **heat recovery**.

TOP **10.6/12 kW**
Nominal cooling/heating capacity for 3 connections + tank

TOP **12.1/13 kW**
Nominal cooling/heating capacity for 4 connections + tank

Higher outputs than everyone else, with the ability to cover combinations that do not saturate nominal capacity thanks to a connection range down to 50%.

TOP **-22°C**
Minimum outdoor temperature in heating or DHW production in winter operation: Multiomnia offers the widest operating range of all competitors in its market segment

Installation flexibility

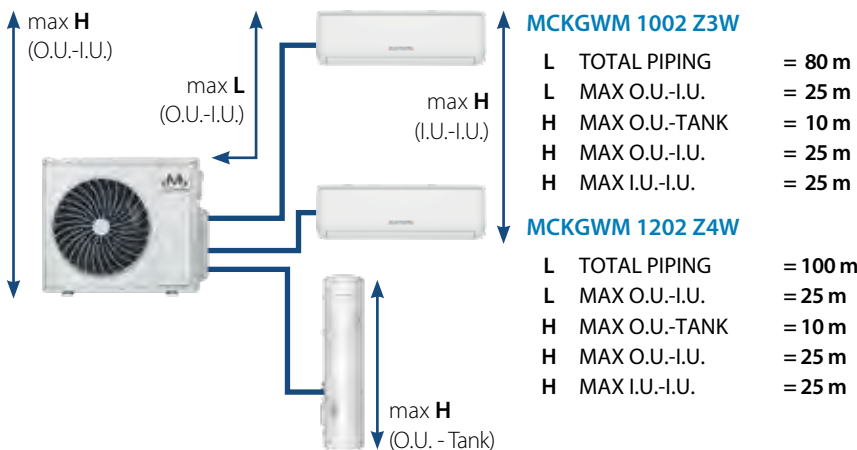

TOP **80/100 m**
Better ability to meet design and installation constraints, thanks to class-leading maximum piping length.

TOP **25/25 m**
Better ability to meet design and installation constraints, thanks to the best maximum height difference between indoor and outdoor units.

The values shown are the result of an internal comparative analysis with the main competitors in the relevant market segment. Values updated in September 2025 based on data in the 2025 public catalogues.

Ask your sales representative for more information.

KEY

TOP Top feature, the best data on the market

Silver Silver feature, one of the best figures on the market

DHW OUTDOOR UNIT

2 CAPACITIES

10.60~12.10 kW

MAXIMUM FLEXIBILITY

ease of installation guaranteed by wide ranges of refrigerant piping splitting

AMPIO RANGE DI FUNZIONAMENTO

riscaldamento e ACS con temperature esterne fino a -22°C

HEAT RECOVERY

with connected tank, free DHW during cooling operation of the indoor air-to-air units.

MCKGWM
1002 Z3W



MCKGWM
1202 Z4W

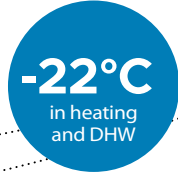

Model	Outdoor unit		MCKGWM 1002 Z3W	MCKGWM 1202 Z4W
Type	DC-Inverter heat pump outdoor unit			
Connectable indoor units (min - max)	in addition to the tank	no.	1 - 3*	1 - 4*
	without tank		2 - 3	2 - 4
* When the tank is connected, it is mandatory to install at least one indoor unit				
Nominal data				
Nominal capacity (T=+35°C)	Cooling	kW	10.60 (2.60~12.00)	12.10 (2.60~15.20)
Nominal absorbed power (T=+35°C)		kW	2.95	3.40
Nominal energy efficiency coefficient		EER ₁	3.59	3.56
Nominal capacity (T=+7°C)	Heating	kW	12.00 (3.00~14.00)	13.00 (3.00~15.50)
Nominal absorbed power (T=+7°C)		kW	3.20	3.35
Nominal energy performance coefficient		COP ₁	3.75	3.88
Nominal capacity (T=+7°C)	DHW	kW	4.20	4.20
Nominal energy performance coefficient		COP ₁	4.56	4.56
Nominal DHW production capacity		L/h	90	90
Seasonal data				
Theoretical load (P _{designc})	Cooling	kW	10.60	12.10
Seasonal energy efficiency index		SEER ₂	7.20	7.20
Seasonal energy efficiency class		626/2011 ³	A++	A++
Annual energy consumption		kWh/y	515	588
Theoretical load (P _{designh}) @ -10°C	Heating (average weather conditions)	kW	10.50	10.80
Seasonal performance coefficient		SCOP ₂	4.20	4.10
Seasonal energy efficiency (η _s)		%	165	161
Seasonal energy efficiency class		626/2011 ³	A+	A+
Annual energy consumption		kWh/y	3500	3600
COP _{DHW4}	Sanitary Water (average weather conditions)	W/W	2.74	2.74
Test cycle profile ⁴		tipo	L	L
Energy efficiency (η _{wh}) ⁵		%	115	115
Energy efficiency class ⁵		814/2013	A+	A+
Electrical data				
Power supply		Ph-V-Hz	1-220~240V-50HZ	
Power cable		Type	3 x 6 mm ²	3 x 6 mm ²
Connection wires between each I.U. and O.U.		no.	4	4
Nominal absorbed current	Cooling	A	13.00	15.00
	Heating	A	14.00	14.80
Maximum current		A	29.50	29.50
Maximum absorbed power		kW	6.50	6.50
Refrigerant circuit data				
Refrigerant ⁶		Type (GWP)	R32 (675)	
Q.ty of refrigerant pre-charge		Kg	2.40	2.40
Tons of CO ₂ equivalent		t	1.620	1.620
Liquid/gas refrigerant pipe diameter		mm (inches)	4 x 6.35(1/4")	5 x 6.35(1/4")
			4 x 9.52(3/8")	5 x 9.52(3/8")
Total split length		m	80	100
Max length of a single refrigerant line		m	25	25
Max difference in height between tank and O.U.		m	10	10
Max difference in height U.I./O.U.		m	25	25
Max difference in height between I.U.		m	25	25
Split length without additional charge		m	40	50
Additional charge		g/m	20	20
Product specifications				
Dimensions	LxDxH	mm	1020x427x826	
Net weight		Kg	72.5	73.5
Sound power level	Max	dB(A)	70	74
Sound pressure level	Max	dB(A)	60	60
Volume of air treated		m ³ /h	5800	5800
Operating limits (outdoor temperature)	Cooling	°C	-15~43	
	Heating		-22~24	
	DHW		-22~43	

Seasonal energy efficiency values refer to the following combinations: MCKGWM 1002 Z3W + 3 x MKEGM 355 ZAL; MCKGWM 1202 Z4W + 2 x MKEGM 265 ZAL + 2 x MKEGM 355 ZAL.

1. Value measured according to harmonized standard EN14511. 2. EU Regulation No. 206/2012 - N.2281/2016 - Value measured according to harmonized standard EN14825. 3. EU Delegated Regulation No. 626/2011 on the new energy labelling of air conditioners. 4. Test according to EN16147; air 7°C, water inlet 10°C [5] Directive 2009/125/EC - ERP EU No. 814/2013 [6] Refrigerant leakage contributes to climate change. When released into the atmosphere, refrigerants with lower global warming potential (GWP) contribute less to global warming than those with a higher GWP. This appliance contains a refrigerant with a GWP of 675. If 1 kg of this refrigerant were released into the atmosphere, the impact on global warming would be 675 times greater than 1 kg of CO₂ over a period of 100 years. Under no circumstances should the user attempt to intervene on the refrigerant circuit or disassemble the product. In case of need, always contact qualified personnel.

TANK



ELECTRIC RESISTANCE INCLUDED

1.5 kW

Connectable only if at least one classic indoor unit is present

MAGNESIUM ANODE

35~55°C

Hot water regulation range

HEAT RECOVERY

Free DHW during cooling operation of the air-to-air indoor units.

Can only be used with outdoor units: MCKGWM 1002 Z3W, MCKGWM 1202 Z4W

Model	Indoor unit	MWTGM 200 Z4W
Type		DHW Tank
Nominal capacity	kW	4.20
Electrical data		
Power supply	Ph-V-Hz	-
Connection wires between I.U. and O.U.	no.	4
Refrigerant circuit data		
Liquid/gas refrigerant pipe diameter	mm (inches)	6.35(1/4") / 9.52(3/8")
Product specifications		
Dimensions	Volume	L
	DxH	mm
	Net weight	kg
Integrative electrical resistance	W	1500
DHW connections	inches	G1/2"
Anode type	-	Magnesio
Hot water Temperature regulation range	°C	35~55
Accessories		
Wired control with WiFi integrated (NOT INCLUDED)		DMW WTGM
Optional parts		
Centralized control		NOT available



462 mm

Narrowest tank diameter on the market. This allows better water stratification, ensuring the end user always draws the hottest water available. In addition, stratification enables the heat pump to work on the coldest water possible, maximising efficiency.



80°C

With the electric heater, the DHW temperature setpoint can be increased up to 80°C - the highest value on the market. The end user can make the most of any self-generated electricity they may have available.

WIRED CONTROL FOR DHW TANK



DMW WTGM Obligatory

Temp +

Manually increases the storage temperature above 55°C using the electric heater, up to 80°C.

Sterilization

Anti-legionella cycle.

Holiday

Setting the absence period, the unit will activate to ensure that the DHW tank is at temperature on the day of return.

Sunflower

The water is heated to a higher temperature the higher the outside temperature, in order to maximize efficiency and reduce costs. Once active, it remains valid for the following days.

Daily and weekly timer

Set on/off times: the setting remains valid for subsequent days/weeks.

Standard mode

Automatic management of the heat pump and electrical resistance for a balanced relationship between heating times and consumption.

Quick mode

Minimizes warm-up times for rapid DHW production.

Energy saving mode

Optimizes water heating while considering energy savings.

Emergency mode

In the event of a heat pump fault, the electrical resistance is automatically activated to produce DHW.

INDOOR UNITS

4 CAPACITIES
2.60~7.20 kW

7 SPEED LEVELS
of ventilation



- I-FEEL FUNCTION
- SELF-CLEAN FUNCTION
- COLD PLASMA FILTER
- REMOTE CONTROL INCLUDED

WALL ACTION



Model			MKEGM 267 ZAL	MKEGM 357 ZAL	MKEGM 537 ZAL	MKEGM 717 ZAL
Type	Wall type indoor unit					
Control	Remote control					
Nominal capacity	Cooling	kW	2.60	3.50	5.00	7.20
	Heating	kW	2.80	3.80	5.60	8.50
Electrical data						
Power supply	Ph-V-Hz		-	-	-	-
Connection wires between I.U. and O.U.	no.		4	4	4	4
Refrigerant circuit data						
Liquid/gas refrigerant pipe diameter	mm (inches)		ø6.35(1/4") / ø9.52(3/8")	ø6.35(1/4") / ø9.52(3/8")	ø6.35(1/4") / ø9.52(3/8")	ø6.35(1/4") / ø12.74(1/2")
Product specifications						
Dimensions	LxDxH	mm	708x185x260	835x200x275	943x246x333	943x246x333
	Net weight	Kg	7	9	13	13.5
Sound power level	Hi~Lo	dB(A)	55/48/46/44/40/37/33	59/50/47/45/41/38/35	60/58/56/54/48/44/41	65/56/54/52/50/46/42
Sound pressure level	Hi~Lo	dB(A)	38/36/34/32/28/25/21	42/38/35/33/29/26/23	47/45/43/41/35/30/28	50/46/44/42/40/36/32
Volume of air treated	Hi~Lo	m ³ /h	500/470/430/390/320/270/250	650/550/470/420/380/350/310	1000/960/870/810/720/640/600	1050/900/740/690/640/590/540
Optional parts						
Individual wired control			M-RF-CW2-L-G / M-RF-CW3-L-G			
Wi-Fi module			Integrated			

4 CAPACITIES
2.60~7.20 kW

ELEGANT & COMPACT DESIGN
210 mm depth for the 2.60 and 3.50 kW models



MAXIMUM SILENCE
only 22 dB(A) in Low mode for the 2.60 kW model

- I-FEEL FUNCTION
- COLD PLASMA FILTER
- REMOTE CONTROL INCLUDED

WALL AIRPRO PLUS



Model			MKEGM 265 ZAL	MKEGM 355 ZAL	MKEGM 535 ZAL	MKEGM 715 ZAL
Type	Wall type indoor unit					
Control	Remote control					
Nominal capacity	Cooling	kW	2.60	3.50	5.00	7.20
	Heating	kW	2.80	3.80	5.60	8.50
Electrical data						
Power supply	Ph-V-Hz		-	-	-	-
Connection wires between I.U. and O.U.	no.		4	4	4	4
Refrigerant circuit data						
Liquid/gas refrigerant pipe diameter	mm (inches)		ø6.35(1/4") / ø9.52(3/8")	ø6.35(1/4") / ø9.52(3/8")	ø6.35(1/4") / ø12.74(1/2")	ø6.35(1/4") / ø15.9(5/8")
Product specifications						
Dimensions	LxDxH	mm	865x290x210	865x290x210	996x301x225	1101x327x249
	Net weight	Kg	10.5	10.5	13	16
Sound power level	Hi~Lo	dB(A)	58/52/50/48/44/40/36	58/53/51/49/46/43/37	60/57/55/54/52/50/46	64/59/56/55/53/51/48
Sound pressure level	Hi~Lo	dB(A)	41/38/36/34/30/26/22	43/39/37/35/32/29/23	43/41/39/37/35/32/31	48/44/41/40/38/36/33
Volume of air treated	Hi~Lo	m ³ /h	660/590/540/490/450/420/390	680/590/540/490/450/420/390	850/750/680/610/570/520/460	1250/1100/1000/950/900/850/800
Optional parts						
Individual wired control			M-RF-CW2-L-G / M-RF-CW3-L-G			
Wi-Fi module			Integrated			

INDOOR UNITS

3 CAPACITIES
2.60~5.00 kW

7 FAN SPEED levels

ELEGANT & COMPACT DESIGN
215 mm deep



**MEMORY FUNCTION,
I-FEEL FUNCTION, X-FAN FUNCTION**

DOUBLE AIR DELIVERY

8° C HEATING

REMOTE CONTROL INCLUDED



Wi-Fi INTEGRATED

CONSOLE

Model	MFIGM 261 ZAL		MFIGM 351 ZAL		MFIGM 531 ZAL	
Type	Console type indoor unit					
Control	Remote control					
Nominal capacity	Cooling	kW	2.60	3.50	5.00	
	Heating	kW	2.80	3.80	5.60	
Electrical data						
Power supply	Ph-V-Hz	-	-	-	-	
Connection wires between I.U. and O.U.	no.	4	4	4		
Refrigerant circuit data						
Liquid/gas refrigerant pipe diameter	mm (inches)	ø6.35(1/4") / ø9.52(3/8")		ø6.35(1/4") / ø9.52(3/8")		ø6.35(1/4") / ø12.74(1/2")
Product specifications						
Dimensions	LxDxH	mm	700x215x600		700x215x600	
	Net weight	Kg	15.5		16	
Sound power level	Hi~Lo	dB(A)	52/48/46/44/41/38/35		60/58/56/53/51/48/43	
Sound pressure level	Hi~Lo	dB(A)	39/36/34/32/29/26/23		44/40/38/36/33/29/25	
Volume of air treated	Hi~Lo	m ³ /h	500/430/410/370/330/280/250		600/520/480/440/400/360/280	
Optional parts						
Individual wired control			M-RF-CW2-L-G / M-RF-CW3-L-G			
Wi-Fi module			Included			

2 CAPACITIES
3.50~5.00 kW

COMPACT DESIGN
265 mm height for recessed installation in false ceilings

MEMORY FUNCTION

COMPACT CASSETTE



TOP

1000

Built-in condensate drain pump, with the highest discharge head (maximum lift) compared with all competitors in its market segment.

WASHABLE FILTER

X-FAN

TOTAL TEMPERATURE CONTROL

REMOTE CONTROL INCLUDED



Wired remote control with optional integrated WiFi

Model	MTFGM 351 ZL		MTFGM 531 ZL	
Type	Cassette type indoor unit			
Control	Remote control			
Nominal capacity	Cooling	kW	3.50	5.00
	Heating	kW	3.80	5.60
Electrical data				
Power supply	Ph-V-Hz	-	-	
Connection wires between I.U. and O.U.	no.	4	4	
Refrigerant circuit data				
Liquid/gas refrigerant pipe diameter	mm (inches)	ø6.35(1/4") / ø9.52(3/8")		ø6.35(1/4") / ø12.74(1/2")
Product specifications				
Dimensions	LxDxH	mm	570x570x265	
	Net weight	Kg	17	
Sound power level	Hi~Lo	dB(A)	57/55/52/50/48/46/44	
Sound pressure level	Hi~Lo	dB(A)	41/39/36/34/32/30/28	
Volume of air treated	Hi~Lo	m ³ /h	560/540/490/450/420/380/350	
Accessories				
Decorative panel	MTFPG 350 ZA			
Optional parts				
Individual wired control with connection cable	M-RF-CW2-L-G + CW2-SE-TF-ADAPTOR			
Wired control for centralized control	M-RF-CW3-L-G			
Wired control with integrated Wi-Fi module	DMW-ZAL-LCAC WiFi			
Centralized control (only possible with wired control)	M-V-CC-T255-G2			

INDOOR UNITS

2 CAPACITIES
3.50~5.00 kW

COMPACT DESIGN
178mm height for recessed installation in false ceilings



TOP
1000
Drain pump with the highest discharge head (maximum lift) compared with all competitors in its market segment.

MEMORY FUNCTION
WASHABLE FILTER
CONDENSATE DRAIN PUMP INCLUDED max height difference **1000 mm**
REMOTE CONTROL INCLUDED

Wired remote control with optional integrated WiFi

1-WAY CASSETTE

Model			MTSGM 351 ZL	MTSGM 531 ZL
Type			Cassette type indoor unit	
Control			Remote control	
Nominal capacity	Cooling	kW	3.50	5.00
	Heating	kW	3.80	5.60
Electrical data				
Power supply		Ph-V-Hz	-	-
Connection wires between I.U. and O.U.		no.	4	4
Refrigerant circuit data				
Liquid/gas refrigerant pipe diameter		mm (inches)	ø6.35(1/4") / ø9.52(3/8")	ø6.35(1/4") / ø12.74(1/2")
Product specifications				
Dimensions	LxDxH	mm	987x385x178	987x385x178
	Net weight	Kg	19	20
Sound power level	Hi~Lo	dB(A)	53/50/43/41	56/53/48/45
Sound pressure level	Hi~Lo	dB(A)	42/39/35/31	43/40/35/32
Volume of air treated	Hi~Lo	m ³ /h	600/500/440/390	700/600/500/450
Accessories			MTSPG 351 Z	
Decorative panel				
Optional parts				
Individual wired control with connection cable			M-RF-CW2-L-G + CW2-SE-TF-ADAPTOR	
Wired control for centralized control			M-RF-CW3-L-G	
Wired control with integrated Wi-Fi module			DMW-ZAL-LCAC WiFi	
Centralized control (only possible with wired control)			M-V-CC-1255-G2	

3 CAPACITIES
2.60~5.00 kW

MAXIMUM COMPACTNESS
only **200 mm** high

MEMORY FUNCTION



TOP
60 Pa
Discharge head value higher than the average for competitors in this market segment.

WASHABLE FILTER
6 FAN SPEED LEVELS
DAILY TIMER
WIRED CONTROL INCLUDED

Wired remote control with optional integrated WiFi

DUCTED

Model			MUCGM 261 ZL	MUCGM 351 ZL	MUCGM 531 ZL
Type			Ducted type indoor unit		
Standard control			Wired control		
Nominal capacity	Cooling	kW	2.60	3.50	5.00
	Heating	kW	2.80	3.80	5.60
Electrical data					
Power supply		Ph-V-Hz	-	-	-
Connection wires between I.U. and O.U.		no.	4	4	4
Refrigerant circuit data					
Liquid/gas refrigerant pipe diameter		mm (inches)	ø6.35(1/4") / ø9.52(3/8")	ø6.35(1/4") / ø9.52(3/8")	ø6.35(1/4") / ø12.74(1/2")
Product specifications					
Dimensions	LxDxH	mm	710x450x200	710x450x200	1010x450x200
	Net weight	Kg	18.5	19	25
Sound power level	Hi~Lo	dB(A)	57/55/54/53/52/51/50	55/53/52/51/50/49/48	57/55/55/54/54/53/50
Sound pressure level	Hi~Lo	dB(A)	41/39/38/37/36/35/34	39/37/36/35/34/33/32	41/39/39/38/38/37/34
Volume of air treated	Hi~Lo	m ³ /h	700/670/640/610/580/550/520	650/560/520/480/450/410/380	880/840/810/790/770/750/730
Fan's static pressure	Std/Max	Pa	25/60	25/60	25/60
Optional parts					
Wi-Fi module			Integrated in the standard wired control		
Centralized control			M-V-CC-1255-G2		

INDOOR UNITS

3 CAPACITIES
2.60~5.00 kW

X-FAN

WASHABLE FILTER

TOTAL TEMPERATURE CONTROL

MEMORY FUNCTION

REMOTE CONTROL INCLUDED



FLOOR/CEILING

Wi-Fi **Wired remote control with optional integrated WiFi**

Model			MSEGM 260 ZL	MSEGM 350 ZL	MSEGM 530 ZL
Type			Ceiling type indoor unit		
Control			Remote control		
Nominal capacity	Cooling	kW	2.60	3.50	5.00
	Heating	kW	2.80	3.80	5.60
Electrical data					
Power supply	Ph-V-Hz		-	-	-
Connection wires between I.U. and O.U.	no.		4	4	4
Refrigerant circuit data					
Liquid/gas refrigerant pipe diameter	mm (inches)		ø6.35(1/4") / ø9.52(3/8")	ø6.35(1/4") / ø9.52(3/8")	ø6.35(1/4") / ø12.74(1/2")
Product specifications					
Dimensions	LxDxH	mm	870x235x665	870x235x665	870x235x665
	Net weight	Kg	25	25	25.5
Sound power level	Hi~Lo	dB(A)	38/35/30/26	38/35/30/26	38/35/30/26
Sound pressure level	Hi~Lo	dB(A)	52/49/44/40	52/49/44/40	52/49/44/40
Volume of air treated	Hi~Lo	m ³ /h	700/610/540/420	700/610/540/420	680/590/520/410
Motor power	Output	W	15	15	15
Optional parts					
Individual wired control con cavetto di collegamento			M-RF-CW2-L-G + CW2-SE-TF-ADAPTOR		
Wired control for centralized control			M-RF-CW3-L-G		
Wired control with integrated Wi-Fi module			DMW-ZAL-LCAC WiFi		
Centralized control (only possible with wired control)			M-V-CC-T255-G2		

R32 COOLING COMBINATIONS

Outdoor units	Combinations					Rated capacity (kW)					Total cooling capacity (kW)			Absorbed power (kW)			EER	SEER	Energy Class
	Unit A	Unit B	Unit C	Unit D	Unit E	Unit A	Unit B	Unit C	Unit D	Unit E	Min	Nom	Max	Min	Nom	Max			
MCKGM 402 Z2	26	-	-	-	-	2.60	-	-	-	-	2.05	2.60	3.00	0.20	0.70	1.30	3.71	6.10	A++
	35	-	-	-	-	3.50	-	-	-	-	2.05	3.50	4.00	0.30	1.00	1.78	3.50	6.10	A++
	26	26	-	-	-	2.05	2.05	-	-	-	2.05	4.10	5.00	0.40	1.10	2.20	3.73	7.20	A++
	26	35	-	-	-	1.76	2.34	-	-	-	2.05	4.10	5.00	0.40	1.10	2.20	3.73	7.20	A++
MCKGM 532 Z2	26	-	-	-	-	2.6	-	-	-	-	2.15	2.60	3.00	0.30	0.70	1.50	3.71	6.10	A++
	35	-	-	-	-	3.5	-	-	-	-	2.15	3.50	3.80	0.30	1.20	1.80	2.92	6.10	A++
	26	26	-	-	-	2.65	2.65	-	-	-	2.15	5.30	5.80	0.40	1.48	2.50	3.58	7.20	A++
	26	35	-	-	-	2.30	3.00	-	-	-	2.15	5.30	5.80	0.50	1.48	2.50	3.58	7.20	A++
MCKGM 602 Z3	35	35	-	-	-	2.65	2.65	-	-	-	2.15	5.30	5.80	0.50	1.48	2.50	3.58	7.20	A++
	26	26	-	-	-	2.65	2.65	-	-	-	2.20	5.30	6.00	0.40	1.20	2.60	4.42	6.10	A++
	26	35	-	-	-	2.60	3.50	-	-	-	2.20	6.10	7.20	0.50	1.48	2.90	4.12	6.10	A++
	26	53	-	-	-	2.03	4.07	-	-	-	2.20	6.10	8.30	0.60	1.48	2.90	4.12	6.10	A++
MCKGM 712 Z3	35	35	-	-	-	3.05	3.05	-	-	-	2.20	6.10	8.30	0.60	1.48	2.90	4.12	6.10	A++
	35	53	-	-	-	2.44	3.66	-	-	-	2.20	6.10	8.30	0.60	1.48	2.90	4.12	6.10	A++
	26	26	26	-	-	2.03	2.03	2.03	-	-	2.20	6.10	8.30	0.60	1.48	2.90	4.12	7.80	A++
	26	26	35	-	-	1.83	1.83	2.44	-	-	2.20	6.10	8.30	0.60	1.48	2.90	4.12	7.80	A++
MCKGM 822 Z4	26	26	-	-	-	2.65	2.65	-	-	-	2.30	5.30	6.30	0.80	1.40	3.00	3.79	6.10	A++
	26	35	-	-	-	2.60	3.50	-	-	-	2.30	6.10	7.30	1.00	1.65	3.20	3.71	6.10	A++
	26	53	-	-	-	2.37	4.73	-	-	-	2.30	7.10	8.50	1.10	1.88	3.40	3.78	6.10	A++
	35	35	-	-	-	3.55	3.55	-	-	-	2.30	7.10	9.20	1.10	1.88	3.40	3.78	6.10	A++
	35	53	-	-	-	2.84	4.26	-	-	-	2.30	7.10	9.20	1.10	1.88	3.40	3.78	6.10	A++
	53	53	-	-	-	3.55	3.55	-	-	-	2.30	7.10	9.20	1.10	1.88	3.40	3.78	6.10	A++
	26	26	26	-	-	2.37	2.37	2.37	-	-	2.30	7.10	9.20	1.10	1.88	3.40	3.78	7.10	A++
	26	26	35	-	-	2.13	2.13	2.84	-	-	2.30	7.10	9.20	1.10	1.88	3.40	3.78	7.10	A++
	26	26	53	-	-	1.78	1.78	3.55	-	-	2.30	7.10	9.20	1.10	1.88	3.40	3.78	7.10	A++
	26	35	35	-	-	1.94	2.58	2.58	-	-	2.30	7.10	9.20	1.10	1.88	3.40	3.78	7.10	A++
MCKGM 1202 Z5	35	35	35	-	-	2.37	2.37	2.37	-	-	2.30	7.10	9.20	1.10	1.88	3.40	3.78	7.10	A++
	26	26	-	-	-	2.65	2.65	-	-	-	2.30	5.30	6.30	0.80	1.40	2.60	3.79	6.10	A++
	26	35	-	-	-	2.60	3.50	-	-	-	2.30	6.10	7.30	0.80	1.60	2.80	3.81	6.10	A++
	26	53	-	-	-	2.60	5.00	-	-	-	2.30	7.60	8.50	1.20	2.00	2.80	3.80	6.10	A++
	35	35	-	-	-	3.50	3.50	-	-	-	2.30	7.00	9.20	1.20	1.80	2.80	3.89	6.10	A++
	35	53	-	-	-	3.20	4.80	-	-	-	2.30	8.00	10.00	1.20	2.12	3.40	3.77	6.10	A++
	53	53	-	-	-	4.00	4.00	-	-	-	2.30	8.00	11.00	1.20	2.12	3.60	3.77	6.10	A++
	26	26	26	-	-	2.67	2.67	2.67	-	-	2.30	8.00	10.00	1.30	2.00	3.40	4.00	6.50	A++
	26	26	35	-	-	2.40	2.40	3.20	-	-	2.30	8.00	11.00	1.30	2.12	3.60	3.77	6.50	A++
	26	26	53	-	-	2.00	2.00	4.00	-	-	2.30	8.00	11.00	1.30	2.12	3.60	3.77	6.50	A++
	26	35	35	-	-	2.18	2.91	2.91	-	-	2.30	8.00	11.00	1.30	2.12	3.60	3.77	6.50	A++
	26	35	53	-	-	1.85	2.46	3.69	-	-	2.30	8.00	11.00	1.30	2.12	3.60	3.77	6.50	A++
	35	35	35	-	-	2.67	2.67	2.67	-	-	2.30	8.00	11.00	1.30	2.12	3.60	3.77	6.50	A++
	35	35	53	-	-	2.29	2.29	3.43	-	-	2.30	8.00	11.00	1.30	2.12	3.60	3.77	6.50	A++
26	26	26	26	-	2.00	2.00	2.00	2.00	-	2.30	8.00	11.00	1.30	2.12	3.60	3.77	7.20	A++	
26	26	26	35	-	1.85	1.85	1.85	2.46	-	2.30	8.00	11.00	1.30	2.12	3.60	3.77	7.20	A++	
26	26	35	35	-	1.71	1.71	2.29	2.29	-	2.30	8.00	11.00	1.30	2.12	3.60	3.77	7.20	A++	
MCKGM 1202 Z5	26	35	-	-	-	2.60	3.50	-	-	-	2.60	6.10	7.50	1.60	2.30	4.60	2.65	6.10	A++
	26	53	-	-	-	2.60	5.00	-	-	-	2.60	7.60	9.00	1.60	2.60	4.60	2.92	6.10	A++
	26	71	-	-	-	2.60	7.20	-	-	-	2.60	9.80	11.00	1.60	3.40	4.60	2.88	6.10	A++
	35	35	-	-	-	3.50	3.50	-	-	-	2.60	7.00	9.20	1.60	2.40	4.60	2.92	6.10	A++
	35	53	-	-	-	3.50	5.00	-	-	-	2.60	8.50	10.00	1.60	3.00	4.60	2.83	6.10	A++
	35	71	-	-	-	3.50	7.10	-	-	-	2.60	10.60	12.00	1.60	3.40	4.60	3.12	6.10	A++
	53	53	-	-	-	5.30	5.30	-	-	-	2.60	10.60	12.00	1.60	3.40	4.60	3.12	6.10	A++
	53	71	-	-	-	4.55	6.05	-	-	-	2.60	10.60	12.00	1.60	3.40	4.60	3.12	6.10	A++
	71	71	-	-	-	5.30	5.30	-	-	-	2.60	10.60	12.00	1.60	3.40	4.60	3.12	6.10	A++
	26	26	26	-	-	2.67	2.67	2.67	-	-	2.60	8.00	10.00	1.60	2.80	4.60	2.86	6.10	A++
	26	26	35	-	-	2.60	2.60	4.20	-	-	2.60	9.40	11.00	1.60	3.40	4.60	2.76	6.10	A++
	26	26	53	-	-	2.60	2.60	5.00	-	-	2.60	10.20	13.02	1.60	3.00	4.60	3.40	6.10	A++
	26	26	71	-	-	2.60	2.60	6.90	-	-	2.60	12.10	15.20	1.60	3.40	4.60	3.56	6.10	A++
	26	35	35	-	-	2.60	3.50	3.50	-	-	2.60	9.60	11.94	1.60	3.00	4.60	3.20	6.10	A++
	26	35	53	-	-	2.60	3.50	5.00	-	-	2.60	11.10	14.11	1.60	3.40	4.60	3.26	6.10	A++
	26	35	71	-	-	2.40	3.20	6.50	-	-	2.60	12.10	15.20	1.60	3.40	4.60	3.56	6.10	A++
26	53	53	-	-	2.50	4.80	4.80	-	-	2.60	12.10	15.20	1.60	3.40	4.60	3.56	6.10	A++	
26	71	71	-	-	2.10	4.30	5.70	-	-	2.60	12.10	15.20	1.60	3.40	4.60	3.56	6.10	A++	
35	35	35	-	-	1.90	5.10	5.10	-	-	2.60	12.10	15.20	1.60	3.40	4.60	3.56	6.10	A++	
35	35	35	-	-	3.50	3.50	3.50	-	-	2.60	10.50	13.02	1.60	3.00	4.60	3.50	6.10	A++	

Energy Class = EU Delegated Regulation No. 626/2011 on the new labelling indicating the energy consumption of air conditioners.
 SEER = EU Regulation No. 206/2012 - Value measured according to the harmonized standard EN14825.
 EER = Value measured according to the harmonized standard EN14511.

R32 COOLING COMBINATIONS

Outdoor units	Combinations					Rated capacity (kW)					Total cooling capacity (kW)			Absorbed power (kW)			EER	SEER	Energy Class
	Unit A	Unit B	Unit C	Unit D	Unit E	Unit A	Unit B	Unit C	Unit D	Unit E	Min	Nom	Max	Min	Nom	Max			
MCKGM 1202 ZS	35	35	53	-	-	3.50	3.50	5.10	-	-	2.60	12.10	15.20	1.60	3.40	4.60	3.56	6.10	A++
	35	35	71	-	-	3.00	3.00	6.10	-	-	2.60	12.10	15.20	1.60	3.40	4.60	3.56	6.10	A++
	35	53	53	-	-	3.10	4.50	4.50	-	-	2.60	12.10	15.20	1.60	3.40	4.60	3.56	6.10	A++
	35	53	71	-	-	2.70	4.00	5.40	-	-	2.60	12.10	15.20	1.60	3.40	4.60	3.56	6.10	A++
	35	71	71	-	-	2.50	4.80	4.80	-	-	2.60	12.10	15.20	1.60	3.40	4.60	3.56	6.10	A++
	53	53	53	-	-	4.03	4.03	4.03	-	-	2.60	12.10	15.20	1.60	3.40	4.60	3.56	6.10	A++
	53	53	71	-	-	3.60	3.60	4.90	-	-	2.60	12.10	15.20	1.60	3.40	4.60	3.56	6.10	A++
	26	26	26	26	-	2.60	2.60	2.60	2.60	-	2.60	10.40	13.02	1.60	3.40	4.60	3.06	7.20	A++
	26	26	26	35	-	2.60	2.60	2.60	3.50	-	2.60	11.30	14.11	1.60	3.40	4.60	3.32	7.20	A++
	26	26	26	53	-	2.42	2.42	2.42	4.84	-	2.60	12.10	15.20	1.60	3.40	4.60	3.56	6.10	A++
	26	26	26	71	-	2.14	2.14	2.14	5.69	-	2.60	12.10	15.20	1.60	3.40	4.60	3.56	6.10	A++
	26	26	35	35	-	2.59	2.59	3.46	3.46	-	2.60	12.10	15.20	1.60	3.40	4.60	3.56	7.20	A++
	26	26	35	53	-	2.27	2.27	3.03	4.54	-	2.60	12.10	15.20	1.60	3.40	4.60	3.56	6.10	A++
	26	26	35	71	-	2.02	2.02	2.69	5.38	-	2.60	12.10	15.20	1.60	3.40	4.60	3.56	6.10	A++
	26	26	53	53	-	2.02	2.02	4.03	4.03	-	2.60	12.10	15.20	1.60	3.40	4.60	3.56	6.10	A++
	26	26	53	71	-	1.82	1.82	3.63	4.84	-	2.60	12.10	15.20	1.60	3.40	4.60	3.56	6.10	A++
	26	35	35	35	-	2.42	3.23	3.23	3.23	-	2.60	12.10	15.20	1.60	3.40	4.60	3.56	7.20	A++
	26	35	35	53	-	2.14	2.85	2.85	4.27	-	2.60	12.10	15.20	1.60	3.40	4.60	3.56	6.10	A++
	26	35	35	71	-	1.91	2.55	2.55	5.09	-	2.60	12.10	15.20	1.60	3.40	4.60	3.56	6.10	A++
	26	35	53	53	-	1.91	2.55	3.82	3.82	-	2.60	12.10	15.20	1.60	3.40	4.60	3.56	6.10	A++
	26	35	53	71	-	1.73	2.30	3.46	4.61	-	2.60	12.10	15.20	1.60	3.40	4.60	3.56	6.10	A++
	26	53	53	53	-	1.73	3.46	3.46	3.46	-	2.60	12.10	15.20	1.60	3.40	4.60	3.56	6.10	A++
	35	35	35	35	-	3.03	3.03	3.03	3.03	-	2.60	12.10	15.20	1.60	3.40	4.60	3.56	7.20	A++
	35	35	35	53	-	2.69	2.69	2.69	4.03	-	2.60	12.10	15.20	1.60	3.40	4.60	3.56	6.10	A++
	35	35	35	71	-	2.42	2.42	2.42	4.84	-	2.60	12.10	15.20	1.60	3.40	4.60	3.56	6.10	A++
	35	35	53	53	-	2.42	2.42	3.63	3.63	-	2.60	12.10	15.20	1.60	3.40	4.60	3.56	6.10	A++
	26	26	26	26	26	2.42	2.42	2.42	2.42	2.42	2.60	12.10	15.20	1.60	3.40	4.60	3.56	7.20	A++
	26	26	26	26	35	2.27	2.27	2.27	2.27	3.03	2.60	12.10	15.20	1.60	3.40	4.60	3.56	7.20	A++
	26	26	26	26	53	2.02	2.02	2.02	2.02	4.03	2.60	12.10	15.20	1.60	3.40	4.60	3.56	6.10	A++
	26	26	26	26	71	1.82	1.82	1.82	1.82	4.84	2.60	12.10	15.20	1.60	3.40	4.60	3.56	6.10	A++
	26	26	26	35	35	2.14	2.14	2.14	2.85	2.85	2.60	12.10	15.20	1.60	3.40	4.60	3.56	6.10	A++
	26	26	26	35	53	1.91	1.91	1.91	2.55	3.82	2.60	12.10	15.20	1.60	3.40	4.60	3.56	7.20	A++
	26	26	26	35	71	1.73	1.73	1.73	2.30	4.61	2.60	12.10	15.20	1.60	3.40	4.60	3.56	6.10	A++
	26	26	26	53	53	1.73	1.73	1.73	3.46	3.46	2.60	12.10	15.20	1.60	3.40	4.60	3.56	6.10	A++
	26	26	35	35	35	2.02	2.02	2.69	2.69	2.69	2.60	12.10	15.20	1.60	3.40	4.60	3.56	7.20	A++
	26	26	35	35	53	1.82	1.82	2.42	2.42	3.63	2.60	12.10	15.20	1.60	3.40	4.60	3.56	6.10	A++
	26	35	35	35	35	1.91	2.55	2.55	2.55	2.55	2.60	12.10	15.20	1.60	3.40	4.60	3.56	7.20	A++
	26	35	35	35	53	1.73	2.30	2.30	2.30	3.46	2.60	12.10	15.20	1.60	3.40	4.60	3.56	6.10	A++
	35	35	35	35	35	2.42	2.42	2.42	2.42	2.42	2.60	12.10	15.20	1.60	3.40	4.60	3.56	7.20	A++

Energy Class = EU Delegated Regulation No. 626/2011 on the new labelling indicating the energy consumption of air conditioners.
SEER = EU Regulation No. 206/2012 - Value measured according to the harmonized standard EN14825.
EER = Value measured according to the harmonized standard EN14511.

R32 HEATING COMBINATIONS

Outdoor units	Combinations					Rated capacity (kW)					Total heating capacity (kW)			Absorbed power (kW)			COP	SCOP	Energy Class	
	Unit A	Unit B	Unit C	Unit D	Unit E	Unit A	Unit B	Unit C	Unit D	Unit E	Min	Nom	Max	Min	Nom	Max				
MCKGM 402 Z2	26	-	-	-	-	2.80	-	-	-	-	2.49	2.80	3.02	0.30	0.80	1.80	3.50	4.00	A+	
	35	-	-	-	-	3.80	-	-	-	-	2.49	3.80	4.10	0.40	0.80	2.00	4.75	4.00	A+	
	26	26	-	-	-	2.20	2.20	-	-	-	2.50	4.40	5.40	0.60	0.97	2.25	4.54	4.20	A+	
	26	35	-	-	-	1.89	2.51	-	-	-	2.50	4.40	5.40	0.60	0.97	2.25	4.54	4.20	A+	
MCKGM 532 Z2	26	-	-	-	-	2.80	-	-	-	-	2.58	2.80	3.02	0.40	0.80	1.80	3.50	4.00	A+	
	35	-	-	-	-	3.80	-	-	-	-	2.58	3.80	4.10	0.40	0.80	2.00	4.75	4.00	A+	
	26	26	-	-	-	2.70	2.70	-	-	-	2.58	5.65	6.50	0.70	1.25	2.50	4.52	4.20	A+	
	26	35	-	-	-	2.31	3.09	-	-	-	2.58	5.65	6.50	0.70	1.25	2.50	4.52	4.20	A+	
	35	35	-	-	-	2.70	2.70	-	-	-	2.58	5.65	6.50	0.70	1.25	2.50	4.52	4.20	A+	
MCKGM 602 Z3	26	26	-	-	-	2.80	2.80	-	-	-	2.70	5.60	8.50	0.60	1.23	2.50	4.57	4.00	A+	
	26	35	-	-	-	2.70	3.80	-	-	-	2.70	6.50	8.50	0.80	1.43	2.90	4.55	4.00	A+	
	26	53	-	-	-	2.17	4.33	-	-	-	2.70	6.50	8.50	0.80	1.43	2.90	4.55	4.00	A+	
	35	35	-	-	-	3.25	3.25	-	-	-	2.70	6.50	8.50	0.80	1.43	2.90	4.55	4.00	A+	
	35	53	-	-	-	2.60	3.90	-	-	-	2.70	6.50	8.50	0.80	1.43	2.90	4.55	4.00	A+	
	26	26	26	-	-	2.17	2.17	2.17	-	-	2.70	6.50	8.50	0.80	1.43	2.90	4.55	4.30	A+	
	26	26	35	-	-	1.95	1.95	2.60	-	-	2.70	6.50	8.50	0.80	1.43	2.90	4.55	4.30	A+	
MCKGM 712 Z3	26	26	-	-	-	2.60	2.60	-	-	-	2.80	6.40	8.80	0.60	1.67	2.40	3.83	4.00	A+	
	26	35	-	-	-	2.60	3.80	-	-	-	2.80	7.50	8.80	0.60	1.95	2.60	3.84	4.00	A+	
	26	53	-	-	-	2.80	5.60	-	-	-	2.80	8.60	8.80	0.80	2.23	3.00	3.86	4.00	A+	
	35	35	-	-	-	4.25	4.25	-	-	-	2.80	8.60	8.80	0.80	2.23	3.00	3.86	4.00	A+	
	35	53	-	-	-	3.40	5.10	-	-	-	2.80	8.60	8.80	0.80	2.23	3.00	3.86	4.00	A+	
	53	53	-	-	-	4.25	4.25	-	-	-	2.80	8.60	8.80	0.80	2.23	3.00	3.86	4.00	A+	
	26	26	26	-	-	2.83	2.83	2.83	-	-	2.80	8.60	9.20	0.80	2.23	3.00	3.86	4.30	A+	
	26	26	35	-	-	2.55	2.55	3.40	-	-	2.80	8.60	9.20	0.80	2.23	3.00	3.86	4.30	A+	
	26	26	53	-	-	2.13	2.13	4.25	-	-	2.80	8.60	9.20	0.80	2.23	3.00	3.86	4.30	A+	
	26	35	35	-	-	2.32	3.09	3.09	-	-	2.80	8.60	9.20	0.80	2.23	3.00	3.86	4.30	A+	
	35	35	35	-	-	2.83	2.83	2.83	-	-	2.80	8.60	9.20	0.80	2.23	3.00	3.86	4.30	A+	
	MCKGM 822 Z4	26	26	-	-	-	2.80	2.80	-	-	-	2.80	5.60	10.00	0.70	1.41	2.50	3.96	4.00	A+
26		35	-	-	-	2.80	5.43	-	-	-	2.80	8.23	10.25	0.70	1.65	2.60	4.99	4.00	A+	
26		53	-	-	-	2.80	3.80	-	-	-	2.80	6.60	10.25	1.00	2.12	3.40	3.11	4.00	A+	
35		35	-	-	-	3.80	3.80	-	-	-	2.80	7.60	10.25	0.90	1.89	2.80	4.03	4.00	A+	
35		53	-	-	-	3.80	5.60	-	-	-	2.80	9.40	10.25	1.00	2.20	3.60	4.27	4.00	A+	
53		53	-	-	-	4.75	4.75	-	-	-	2.80	9.50	10.25	1.00	2.20	3.60	4.32	4.00	A+	
26		26	26	-	-	3.17	3.17	3.17	-	-	2.80	9.50	10.25	1.00	2.12	3.40	4.48	4.00	A+	
26		26	35	-	-	2.85	2.85	3.80	-	-	2.80	9.50	10.25	1.00	2.20	3.60	4.32	4.00	A+	
26		26	53	-	-	2.38	2.38	4.75	-	-	2.80	9.50	10.25	1.00	2.20	3.60	4.32	4.00	A+	
26		35	35	-	-	2.59	3.45	3.45	-	-	2.80	9.50	10.25	1.00	2.20	3.60	4.32	4.00	A+	
26		35	53	-	-	2.19	2.92	4.38	-	-	2.80	9.50	10.25	1.00	2.20	3.60	4.32	4.00	A+	
35		35	35	-	-	3.17	3.17	3.17	-	-	2.80	9.50	10.25	1.00	2.20	3.60	4.32	4.00	A+	
35		35	53	-	-	2.71	2.71	4.07	-	-	2.80	9.50	10.25	1.00	2.20	3.60	4.32	4.00	A+	
26		26	26	26	-	2.38	2.38	2.38	2.38	-	2.80	9.50	10.25	1.00	2.20	3.60	4.32	4.20	A+	
26		26	26	35	-	2.19	2.19	2.19	2.92	-	2.80	9.50	10.25	1.00	2.20	3.60	4.32	4.20	A+	
26		26	26	35	35	-	2.04	2.04	2.71	2.71	-	2.80	9.50	10.25	1.00	2.20	3.60	4.32	4.20	A+
MCKGM 1202 Z5		26	35	-	-	-	2.80	3.80	-	-	-	3.00	6.60	7.75	1.61	2.30	4.20	2.87	4.00	A+
	26	53	-	-	-	2.80	5.60	-	-	-	3.00	8.40	9.96	1.61	2.60	4.50	3.23	4.00	A+	
	26	71	-	-	-	2.80	8.50	-	-	-	3.00	11.30	12.17	1.61	2.80	4.50	4.04	4.00	A+	
	35	35	-	-	-	3.80	3.80	-	-	-	3.00	7.60	8.85	1.61	2.60	4.50	2.92	4.00	A+	
	35	53	-	-	-	3.80	5.60	-	-	-	3.00	9.40	11.07	1.61	2.80	4.50	3.36	4.00	A+	
	35	71	-	-	-	3.80	8.50	-	-	-	3.00	12.30	13.28	1.61	2.80	4.50	4.39	4.00	A+	
	53	53	-	-	-	5.60	5.60	-	-	-	3.00	11.20	13.28	1.61	2.80	4.50	4.00	4.00	A+	
	53	71	-	-	-	5.57	7.43	-	-	-	3.00	13.00	15.50	1.61	3.19	5.00	4.08	4.00	A+	
	71	71	-	-	-	6.50	6.50	-	-	-	3.00	13.00	15.50	1.61	3.19	5.00	4.08	4.00	A+	
	26	26	26	-	-	2.80	2.80	2.80	-	-	3.00	8.40	9.96	1.61	2.60	4.50	3.23	4.00	A+	
	26	26	35	-	-	2.80	2.80	3.80	-	-	3.00	9.40	11.07	1.61	2.80	4.50	3.36	4.00	A+	
	26	26	53	-	-	2.80	2.80	5.60	-	-	3.00	11.20	13.28	1.61	2.80	4.50	4.00	4.00	A+	
	26	26	71	-	-	2.79	2.79	7.43	-	-	3.00	13.00	15.50	1.61	3.19	5.00	4.08	4.00	A+	
	26	35	35	-	-	2.80	3.80	3.80	-	-	3.00	10.40	12.17	1.61	2.80	4.50	3.71	4.00	A+	
	26	35	53	-	-	2.80	3.80	5.60	-	-	3.00	12.20	14.39	1.61	3.19	5.00	3.82	4.00	A+	
	26	35	71	-	-	2.60	3.47	6.93	-	-	3.00	13.00	15.50	1.61	3.19	5.00	4.08	4.00	A+	
	26	53	53	-	-	2.60	5.20	5.20	-	-	3.00	13.00	15.50	1.61	3.19	5.00	4.08	4.00	A+	
	26	53	71	-	-	2.29	4.59	6.12	-	-	3.00	13.00	15.50	1.61	3.19	5.00	4.08	4.00	A+	
	26	71	71	-	-	2.05	5.47	5.47	-	-	3.00	13.00	15.50	1.61	3.19	5.00	4.08	4.00	A+	
35	35	35	-	-	4.33	4.33	4.33	-	-	3.00	13.00	13.28	1.61	2.80	4.50	4.64	4.00	A+		

Energy Class = EU Delegated Regulation No. 626/2011 on the new labelling indicating the energy consumption of air conditioners.
 SCOP = EU Regulation No. 206/2012 - Value measured according to the harmonized standard EN14825.
 COP = Value measured according to the harmonized standard EN14511.

R32 HEATING COMBINATIONS

Outdoor units	Combinations					Rated capacity (kW)					Total heating capacity (kW)			Absorbed power (kW)			COP	SCOP	Energy Class
	Unit A	Unit B	Unit C	Unit D	Unit E	Unit A	Unit B	Unit C	Unit D	Unit E	Min	Nom	Max	Min	Nom	Max			
MCKGM 1202 ZS	35	35	53			3.71	3.71	5.57			3.00	13.00	15.50	1.61	3.19	5.00	4.08	4.00	A+
	35	35	71			3.25	3.25	6.50			3.00	13.00	15.50	1.61	3.19	5.00	4.08	4.00	A+
	35	53	53			3.25	4.88	4.88			3.00	13.00	15.50	1.61	3.19	5.00	4.08	4.00	A+
	35	53	71			2.89	4.33	5.78			3.00	13.00	15.50	1.61	3.19	5.00	4.08	4.00	A+
	35	71	71			2.60	5.20	5.20			3.00	13.00	15.50	1.61	3.19	5.00	4.08	4.00	A+
	53	53	53			4.33	4.33	4.33			3.00	13.00	15.50	1.61	3.19	5.00	4.08	4.00	A+
	53	53	71			3.90	3.90	5.20			3.00	13.00	15.50	1.61	3.19	5.00	4.08	4.00	A+
	26	26	26	26		3.25	3.25	3.25	3.25		3.00	13.00	14.00	1.61	3.00	4.80	4.33	4.00	A+
	26	26	26	35		3.00	3.00	3.00	4.00		3.00	13.00	14.39	1.61	3.19	5.00	4.08	4.00	A+
	26	26	26	53		2.60	2.60	2.60	5.20		3.00	13.00	15.50	1.61	3.19	5.00	4.08	4.00	A+
	26	26	26	71		2.29	2.29	2.29	6.12		3.00	13.00	15.50	1.61	3.19	5.00	4.08	4.00	A+
	26	26	35	35		2.79	2.79	3.71	3.71		3.00	13.00	15.50	1.61	3.19	5.00	4.08	4.00	A+
	26	26	35	53		2.44	2.44	3.25	4.88		3.00	13.00	15.50	1.61	3.19	5.00	4.08	4.00	A+
	26	26	35	71		2.17	2.17	2.89	5.78		3.00	13.00	15.50	1.61	3.19	5.00	4.08	4.00	A+
	26	26	53	53		2.17	2.17	4.33	4.33		3.00	13.00	15.50	1.61	3.19	5.00	4.08	4.00	A+
	26	26	53	71		1.95	1.95	3.90	5.20		3.00	13.00	15.50	1.61	3.19	5.00	4.08	4.00	A+
	26	35	35	35		2.60	3.47	3.47	3.47		3.00	13.00	15.50	1.61	3.19	5.00	4.08	4.00	A+
	26	35	35	53		2.29	3.06	3.06	4.59		3.00	13.00	15.50	1.61	3.19	5.00	4.08	4.00	A+
	26	35	35	71		2.05	2.74	2.74	5.47		3.00	13.00	15.50	1.61	3.19	5.00	4.08	4.00	A+
	26	35	53	53		2.05	2.74	4.11	4.11		3.00	13.00	15.50	1.61	3.19	5.00	4.08	4.00	A+
	26	35	53	71		1.86	2.48	3.71	4.95		3.00	13.00	15.50	1.61	3.19	5.00	4.08	4.00	A+
	26	53	53	53		1.86	3.71	3.71	3.71		3.00	13.00	15.50	1.61	3.19	5.00	4.08	4.00	A+
	35	35	35	35		3.25	3.25	3.25	3.25		3.00	13.00	15.50	1.61	3.19	5.00	4.08	4.00	A+
	35	35	35	53		2.89	2.89	2.89	4.33		3.00	13.00	15.50	1.61	3.19	5.00	4.08	4.00	A+
	35	35	35	71		2.60	2.60	2.60	5.20		3.00	13.00	15.50	1.61	3.19	5.00	4.08	4.00	A+
	35	35	53	53		2.60	2.60	3.90	3.90		3.00	13.00	15.50	1.61	3.19	5.00	4.08	4.00	A+
	26	26	26	26	26	2.60	2.60	2.60	2.60	2.60	3.00	13.00	15.50	1.61	3.19	5.00	4.08	4.20	A+
	26	26	26	26	35	2.44	2.44	2.44	2.44	3.25	3.00	13.00	15.50	1.61	3.19	5.00	4.08	4.20	A+
	26	26	26	26	53	2.17	2.17	2.17	2.17	4.33	3.00	13.00	15.50	1.61	3.19	5.00	4.08	4.00	A+
	26	26	26	26	71	1.95	1.95	1.95	1.95	5.20	3.00	13.00	15.50	1.61	3.19	5.00	4.08	4.00	A+
	26	26	26	35	35	2.29	2.29	2.29	3.06	3.06	3.00	13.00	15.50	1.61	3.19	5.00	4.08	4.20	A+
	26	26	26	35	53	2.05	2.05	2.05	2.74	4.11	3.00	13.00	15.50	1.61	3.19	5.00	4.08	4.00	A+
26	26	26	35	71	1.86	1.86	1.86	2.48	4.95	3.00	13.00	15.50	1.61	3.19	5.00	4.08	4.00	A+	
26	26	26	53	53	1.86	1.86	1.86	3.71	3.71	3.00	13.00	15.50	1.61	3.19	5.00	4.08	4.00	A+	
26	26	35	35	35	2.17	2.17	2.89	2.89	2.89	3.00	13.00	15.50	1.61	3.19	5.00	4.08	4.20	A+	
26	26	35	35	53	1.95	1.95	2.60	2.60	3.90	3.00	13.00	15.50	1.61	3.19	5.00	4.08	4.00	A+	
26	35	35	35	35	2.05	2.74	2.74	2.74	2.74	3.00	13.00	15.50	1.61	3.19	5.00	4.08	4.20	A+	
26	35	35	35	53	1.86	2.48	2.48	2.48	3.71	3.00	13.00	15.50	1.61	3.19	5.00	4.08	4.00	A+	
35	35	35	35	35	2.60	2.60	2.60	2.60	2.60	3.00	13.00	15.50	1.61	3.19	5.00	4.08	4.20	A+	

Energy Class = EU Delegated Regulation No. 626/2011 on the new labelling indicating the energy consumption of air conditioners.
 SCOP = EU Regulation No. 206/2012 - - Value measured according to the harmonized standard EN14825.
 COP = Value measured according to the harmonized standard EN14511.

R32 COOLING COMBINATIONS WITHOUT DHW TANK

Outdoor units	Combinations				Rated capacity (kW)				Total cooling capacity (kW)			Absorbed power (kW)			EER	SEER	Energy Class
	Unit A	Unit B	Unit C	Unit D	Unit A	Unit B	Unit C	Unit D	Min	Nom	Max	Min	Nom	Max			
MCKGWM 1002 Z3W	Tank only	26	26		-	2.60	2.60		2.60	5.20	6.50	1.60	1.90	3.50	2.74	6.10	A++
		26	35		-	2.60	3.50		2.60	6.10	7.50	1.60	2.30	3.50	2.65	6.10	A++
		26	53		-	2.60	5.25		2.60	7.85	9.00	1.60	2.40	3.50	3.27	6.10	A++
		26	71		-	2.60	7.10		2.60	9.70	11.00	1.60	2.60	3.60	3.73	6.10	A++
		35	35		-	3.50	3.50		2.60	7.00	9.20	1.60	2.40	3.50	2.92	6.10	A++
		35	53		-	3.50	5.25		2.60	8.75	10.00	1.60	2.40	3.50	3.65	6.10	A++
		35	71		-	3.50	7.10		2.60	10.60	12.00	1.60	2.95	4.60	3.59	6.10	A++
		53	53		-	5.25	5.25		2.60	10.60	12.00	1.60	2.95	4.60	3.59	6.10	A++
		53	71		-	4.54	6.06		2.60	10.60	12.00	1.60	2.95	4.60	3.59	6.10	A++
		71	71		-	5.30	5.30		2.60	10.60	12.00	1.60	2.95	4.60	3.59	6.10	A++
		26	26	26	-	2.60	2.60	2.60	2.60	7.80	10.00	1.60	2.40	3.50	3.25	6.10	A++
		26	26	35	-	2.60	2.60	3.50	2.60	8.70	11.00	1.60	2.60	3.60	3.35	6.10	A++
		26	26	53	-	2.60	2.60	5.25	2.60	10.60	12.00	1.60	2.95	4.60	3.59	6.10	A++
		26	26	71	-	2.27	2.27	6.06	2.60	10.60	12.00	1.60	2.95	4.60	3.59	6.10	A++
		26	35	35	-	2.60	3.50	3.50	2.60	9.60	11.00	1.60	2.60	4.60	3.69	6.10	A++
		26	35	53	-	2.45	3.26	4.89	2.60	10.60	12.00	1.60	2.95	4.60	3.59	6.10	A++
		26	35	71	-	2.12	2.83	5.65	2.60	10.60	12.00	1.60	2.95	4.60	3.59	6.10	A++
		26	53	53	-	2.12	4.24	4.24	2.60	10.60	12.00	1.60	2.95	4.60	3.59	6.10	A++
		26	53	71	-	1.87	3.74	4.99	2.60	10.60	12.00	1.60	2.95	4.60	3.59	6.10	A++
		35	35	35	-	3.50	3.50	3.50	2.60	10.60	12.00	1.60	2.95	4.60	3.59	7.20	A++
		35	35	53	-	3.03	3.03	4.54	2.60	10.60	12.00	1.60	2.95	4.60	3.59	6.10	A++
		35	35	71	-	2.65	2.65	5.30	2.60	10.60	12.00	1.60	2.95	4.60	3.59	6.10	A++
		35	53	53	-	2.65	3.98	3.98	2.60	10.60	12.00	1.60	2.95	4.60	3.59	6.10	A++
		35	53	71	-	2.36	3.53	4.71	2.60	10.60	12.00	1.60	2.95	4.60	3.59	6.10	A++
53	53	53	-	3.53	3.53	3.53	2.60	10.60	12.00	1.60	2.95	4.60	3.59	6.10	A++		

Energy Class = EU Delegated Regulation No. 626/2011 on the new labelling indicating the energy consumption of air conditioners.
 SCOP = EU Regulation No. 206/2012 - - Value measured according to the harmonized standard EN14825.
 COP = Value measured according to the harmonized standard EN14511.

R32 COOLING COMBINATIONS WITHOUT DHW TANK

Outdoor units	Combinations					Rated capacity (kW)					Total DHW yield (kW)			Total cooling performance (kW)			Absorbed power (kW)			
	Unit A	Unit B	Unit C	Unit D	Unit E	Unit A	Unit B	Unit C	Unit D	Unit E	Min	Nom	Max	Min	Nom	Max	Min	Nom	Max	
MCKGWM 1202 24W	Tank only	26	26	-	-	-	2.60	2.60	-	-	2.60	5.20	6.50	1.60	1.90	3.50	2.74	6.10	A++	
		26	35	-	-	-	2.60	3.50	-	-	2.60	6.10	7.50	1.60	2.30	3.50	2.65	6.10	A++	
		26	53	-	-	-	2.60	5.25	-	-	2.60	7.85	9.00	1.60	2.40	3.50	3.27	6.10	A++	
		26	71	-	-	-	2.60	7.10	-	-	2.60	9.70	11.00	1.60	2.60	3.60	3.73	6.10	A++	
		35	35	-	-	-	3.50	3.50	-	-	2.60	7.00	9.20	1.60	2.40	3.50	2.92	6.10	A++	
		35	53	-	-	-	3.50	5.25	-	-	2.60	8.75	10.00	1.60	2.40	3.50	3.65	6.10	A++	
		35	71	-	-	-	3.50	7.10	-	-	2.60	10.60	12.00	1.60	2.95	4.60	3.59	6.10	A++	
		53	53	-	-	-	5.25	5.25	-	-	2.60	10.60	12.00	1.60	2.95	4.60	3.59	6.10	A++	
		53	71	-	-	-	4.54	6.06	-	-	2.60	10.60	12.00	1.60	2.95	4.60	3.59	6.10	A++	
		71	71	-	-	-	5.30	5.30	-	-	2.60	10.60	12.00	1.60	2.95	4.60	3.59	6.10	A++	
		26	26	26	-	-	2.60	2.60	2.60	-	-	2.60	7.80	10.00	1.60	2.40	3.50	3.25	6.10	A++
		26	26	35	-	-	2.60	2.60	3.50	-	-	2.60	8.70	11.00	1.60	2.60	3.60	3.35	6.10	A++
		26	26	53	-	-	2.60	2.60	5.25	-	-	2.60	10.60	12.00	1.60	2.95	4.60	3.59	6.10	A++
		26	26	71	-	-	2.27	2.27	6.06	-	-	2.60	10.60	12.00	1.60	2.95	4.60	3.59	6.10	A++
		26	35	35	-	-	2.60	3.50	3.50	-	-	2.60	9.60	11.00	1.60	2.60	4.60	3.69	6.10	A++
		26	35	53	-	-	2.45	3.26	4.89	-	-	2.60	10.60	12.00	1.60	2.95	4.60	3.59	6.10	A++
		26	35	71	-	-	2.12	2.83	5.65	-	-	2.60	10.60	12.00	1.60	2.95	4.60	3.59	6.10	A++
		26	53	53	-	-	2.12	4.24	4.24	-	-	2.60	10.60	12.00	1.60	2.95	4.60	3.59	6.10	A++
		26	53	71	-	-	1.87	3.74	4.99	-	-	2.60	10.60	12.00	1.60	2.95	4.60	3.59	6.10	A++
		35	35	35	-	-	3.50	3.50	3.50	-	-	2.60	10.60	12.00	1.60	2.95	4.60	3.59	7.20	A++
		35	35	53	-	-	3.03	3.03	4.54	-	-	2.60	10.60	12.00	1.60	2.95	4.60	3.59	6.10	A++
		35	35	71	-	-	2.65	2.65	5.30	-	-	2.60	10.60	12.00	1.60	2.95	4.60	3.59	6.10	A++
		35	53	53	-	-	2.65	3.98	3.98	-	-	2.60	10.60	12.00	1.60	2.95	4.60	3.59	6.10	A++
		35	53	71	-	-	2.36	3.53	4.71	-	-	2.60	10.60	12.00	1.60	2.95	4.60	3.59	6.10	A++
		53	53	53	-	-	3.53	3.53	3.53	-	-	2.60	10.60	12.00	1.60	2.95	4.60	3.59	6.10	A++
		53	53	71	-	-	3.63	3.63	4.84	-	-	2.60	12.10	15.20	1.60	3.40	4.60	3.56	6.10	A++
		26	26	26	26	-	2.60	2.60	2.60	2.60	2.60	2.60	10.60	13.02	1.60	3.00	4.60	3.53	6.10	A++
		26	26	26	35	-	2.60	2.60	2.60	3.50	2.60	2.60	11.30	14.11	1.60	3.20	4.60	3.53	6.10	A++
		26	26	26	53	-	2.42	2.42	2.42	4.84	2.60	2.60	12.10	15.20	1.60	3.40	4.60	3.56	6.10	A++
		26	26	26	71	-	2.14	2.14	2.14	5.69	2.60	2.60	12.10	15.20	1.60	3.40	4.60	3.56	6.10	A++
		26	26	35	35	-	2.59	2.59	3.46	3.46	2.60	2.60	12.10	15.20	1.60	3.40	4.60	3.56	7.20	A++
		26	26	35	53	-	2.27	2.27	3.03	4.54	2.60	2.60	12.10	15.20	1.60	3.40	4.60	3.56	6.10	A++
		26	26	35	71	-	2.02	2.02	2.69	5.38	2.60	2.60	12.10	15.20	1.60	3.40	4.60	3.56	6.10	A++
		26	26	53	53	-	2.02	2.02	4.03	4.03	2.60	2.60	12.10	15.20	1.60	3.40	4.60	3.56	6.10	A++
		26	26	53	71	-	1.82	1.82	3.63	4.84	2.60	2.60	12.10	15.20	1.60	3.40	4.60	3.56	6.10	A++
		26	35	35	35	-	2.42	3.23	3.23	3.23	2.60	2.60	12.10	15.20	1.60	3.40	4.60	3.56	6.10	A++
		26	35	35	53	-	2.14	2.85	2.85	4.27	2.60	2.60	12.10	15.20	1.60	3.40	4.60	3.56	6.10	A++
		26	35	35	71	-	1.91	2.55	2.55	5.09	2.60	2.60	12.10	15.20	1.60	3.40	4.60	3.56	6.10	A++
		26	35	53	53	-	1.91	2.55	3.82	3.82	2.60	2.60	12.10	15.20	1.60	3.40	4.60	3.56	6.10	A++
		26	35	53	71	-	1.73	2.30	3.46	4.61	2.60	2.60	12.10	15.20	1.60	3.40	4.60	3.56	6.10	A++
26	53	53	53	-	1.73	3.46	3.46	3.46	2.60	2.60	12.10	15.20	1.60	3.40	4.60	3.56	6.10	A++		
35	35	35	35	-	3.03	3.03	3.03	3.03	2.60	2.60	12.10	15.20	1.60	3.40	4.60	3.56	6.10	A++		
35	35	35	53	-	2.69	2.69	2.69	4.03	2.60	2.60	12.10	15.20	1.60	3.40	4.60	3.56	6.10	A++		
35	35	35	71	-	2.42	2.42	2.42	4.84	2.60	2.60	12.10	15.20	1.60	3.40	4.60	3.56	6.10	A++		
35	35	53	53	-	2.42	2.42	3.63	3.63	2.60	2.60	12.10	15.20	1.60	3.40	4.60	3.56	6.10	A++		

Energy Class = EU Delegated Regulation No. 626/2011 on the new labelling indicating the energy consumption of air conditioners.
 SCOP = EU Regulation No. 206/2012 - - Value measured according to the harmonized standard EN14825.
 COP = Value measured according to the harmonized standard EN14511.

R32 HEATING COMBINATIONS WITHOUT DHW TANK

Outdoor units	Combinations				Rated capacity (kW)				Total heating capacity (kW)			Absorbed power (kW)			COP	SCOP	Energy Class
	Unit A	Unit B	Unit C	Unit D	Unit A	Unit B	Unit C	Unit D	Min	Nom	Max	Min	Nom	Max			
MCKGWM 1002 Z3W	Tank only	26	26		-	2.80	2.80		3.00	5.60	7.00	1.61	1.90	3.60	2.95	4.0	A+
		26	35		-	2.80	3.80		3.00	6.60	8.16	1.61	2.30	3.80	2.87	4.0	A+
		26	53		-	2.80	5.60		3.00	8.40	10.50	1.61	2.80	4.20	3.00	4.0	A+
		26	71		-	2.80	8.20		3.00	11.00	12.83	1.61	3.04	5.00	3.62	4.0	A+
		35	35		-	3.80	3.80		3.00	7.60	9.33	1.61	2.60	4.00	2.92	4.0	A+
		35	53		-	3.80	5.60		3.00	9.40	11.66	1.61	2.90	4.80	3.24	4.0	A+
		35	71		-	3.80	8.20		3.00	12.00	14.00	1.61	3.20	5.00	3.75	4.0	A+
		53	53		-	5.60	5.60		3.00	12.00	14.00	1.61	3.20	5.00	3.75	4.0	A+
		53	71		-	5.14	6.86		3.00	12.00	14.00	1.61	3.20	5.00	3.75	4.0	A+
		71	71		-	6.00	6.00		3.00	12.00	14.00	1.61	3.20	5.00	3.75	4.0	A+
		26	26	26	-	2.80	2.80	2.80	3.00	8.40	10.50	1.61	2.80	4.20	3.00	4.0	A+
		26	26	35	-	2.80	2.80	3.80	3.00	9.40	11.66	1.61	2.90	4.80	3.24	4.0	A+
		26	26	53	-	2.80	2.80	5.60	3.00	12.00	14.00	1.61	3.20	5.00	3.75	4.0	A+
		26	26	71	-	2.57	2.57	6.86	3.00	12.00	14.00	1.61	3.20	5.00	3.75	4.0	A+
		26	35	35	-	2.80	3.80	3.80	3.00	10.40	12.83	1.61	3.04	5.00	3.42	4.0	A+
		26	35	53	-	2.77	3.69	5.54	3.00	12.00	14.00	1.61	3.20	5.00	3.75	4.0	A+
		26	35	71	-	2.40	3.20	6.40	3.00	12.00	14.00	1.61	3.20	5.00	3.75	4.0	A+
		26	53	53	-	2.40	4.80	4.80	3.00	12.00	14.00	1.61	3.20	5.00	3.75	4.0	A+
		26	53	71	-	2.12	4.24	5.65	3.00	12.00	14.00	1.61	3.20	5.00	3.75	4.0	A+
		35	35	35	-	3.80	3.80	3.80	3.00	12.00	14.00	1.61	3.20	5.00	3.75	4.2	A+
		35	35	53	-	3.43	3.43	5.14	3.00	12.00	14.00	1.61	3.20	5.00	3.75	4.2	A+
		35	35	71	-	3.00	3.00	6.00	3.00	12.00	14.00	1.61	3.20	5.00	3.75	4.2	A+
		35	53	53	-	3.00	4.50	4.50	3.00	12.00	14.00	1.61	3.20	5.00	3.75	4.2	A+
		35	53	71	-	2.67	4.00	5.33	3.00	12.00	14.00	1.61	3.20	5.00	3.75	4.2	A+
53	53	53	-	4.00	4.00	4.00	3.00	12.00	14.00	1.61	3.20	5.00	3.75	4.2	A+		

Energy Class = EU Delegated Regulation No. 626/2011 on the new labelling indicating the energy consumption of air conditioners.
 SCOP = EU Regulation No. 206/2012 - - Value measured according to the harmonized standard EN14825.
 COP = Value measured according to the harmonized standard EN14511.

R32 HEATING COMBINATIONS WITHOUT DHW TANK

Outdoor units	Combinations					Rated capacity (kW)					Total heating capacity (kW)			Absorbed power (kW)			COP	SCOP	Energy Class	
	Unit A	Unit B	Unit C	Unit D	Unit E	Unit A	Unit B	Unit C	Unit D	Unit E	Min	Nom	Max	Min	Nom	Max				
MCKGWM 1202 24W	Tank only	26	26	-	-	-	2.80	2.80	-	-	3.00	5.60	7.00	1.61	1.90	3.60	2.95	4.0	A+	
		26	35	-	-	-	2.80	3.80	-	-	3.00	6.60	8.16	1.61	2.30	3.80	2.87	4.0	A+	
		26	53	-	-	-	2.80	5.60	-	-	3.00	8.40	10.50	1.61	2.80	4.20	3.00	4.0	A+	
		26	71	-	-	-	2.80	8.20	-	-	3.00	11.00	12.83	1.61	3.04	5.00	3.62	4.0	A+	
		35	35	-	-	-	3.80	3.80	-	-	3.00	7.60	9.33	1.61	2.60	4.00	2.92	4.0	A+	
		35	53	-	-	-	3.80	5.60	-	-	3.00	9.40	11.66	1.61	2.90	4.80	3.24	4.0	A+	
		35	71	-	-	-	3.80	8.20	-	-	3.00	12.00	14.00	1.61	3.20	5.00	3.75	4.0	A+	
		53	53	-	-	-	5.60	5.60	-	-	3.00	12.00	14.00	1.61	3.20	5.00	3.75	4.0	A+	
		53	71	-	-	-	5.14	6.86	-	-	3.00	12.00	14.00	1.61	3.20	5.00	3.75	4.0	A+	
		71	71	-	-	-	6.00	6.00	-	-	3.00	12.00	14.00	1.61	3.20	5.00	3.75	4.0	A+	
		26	26	26	-	-	2.80	2.80	2.80	-	-	3.00	8.40	10.50	1.61	2.80	4.20	3.00	4.0	A+
		26	26	35	-	-	2.80	2.80	3.80	-	-	3.00	9.40	11.66	1.61	2.90	4.80	3.24	4.0	A+
		26	26	53	-	-	2.80	2.80	5.60	-	-	3.00	12.00	14.00	1.61	3.20	5.00	3.75	4.0	A+
		26	26	71	-	-	2.57	2.57	6.86	-	-	3.00	12.00	14.00	1.61	3.20	5.00	3.75	4.0	A+
		26	35	35	-	-	2.80	3.80	3.80	-	-	3.00	10.40	12.83	1.61	3.04	5.00	3.42	4.0	A+
		26	35	53	-	-	2.77	3.69	5.54	-	-	3.00	12.00	14.00	1.61	3.20	5.00	3.75	4.0	A+
		26	35	71	-	-	2.40	3.20	6.40	-	-	3.00	12.00	14.00	1.61	3.20	5.00	3.75	4.0	A+
		26	53	53	-	-	2.40	4.80	4.80	-	-	3.00	12.00	14.00	1.61	3.20	5.00	3.75	4.0	A+
		26	53	71	-	-	2.12	4.24	5.65	-	-	3.00	12.00	14.00	1.61	3.20	5.00	3.75	4.0	A+
		35	35	35	-	-	3.80	3.80	3.80	-	-	3.00	12.00	14.00	1.61	3.20	5.00	3.75	4.2	A+
		35	35	53	-	-	3.43	3.43	5.14	-	-	3.00	12.00	14.00	1.61	3.20	5.00	3.75	4.2	A+
		35	35	71	-	-	3.00	3.00	6.00	-	-	3.00	12.00	14.00	1.61	3.20	5.00	3.75	4.2	A+
		35	53	53	-	-	3.00	4.50	4.50	-	-	3.00	12.00	14.00	1.61	3.20	5.00	3.75	4.2	A+
		35	53	71	-	-	2.67	4.00	5.33	-	-	3.00	12.00	14.00	1.61	3.20	5.00	3.75	4.2	A+
		53	53	53	-	-	4.00	4.00	4.00	-	-	3.00	12.00	14.00	1.61	3.20	5.00	3.75	4.2	A+
		53	53	71	-	-	3.90	3.90	5.20	-	-	3.00	13.00	15.50	1.61	3.35	5.00	3.88	4.0	A+
		26	26	26	26	-	2.80	2.80	2.80	2.80	-	3.00	12.00	14.00	1.61	3.20	4.80	3.75	4.1	A+
		26	26	26	35	-	2.80	2.80	2.80	3.80	-	3.00	12.50	14.39	1.61	3.20	5.00	3.91	4.1	A+
		26	26	26	53	-	2.60	2.60	2.60	5.20	-	3.00	13.00	15.50	1.61	3.35	5.00	3.88	4.1	A+
		26	26	26	71	-	2.29	2.29	2.29	6.12	-	3.00	13.00	15.50	1.61	3.35	5.00	3.88	4.1	A+
		26	26	35	35	-	2.79	2.79	3.71	3.71	-	3.00	13.00	15.50	1.61	3.35	5.00	3.88	4.1	A+
		26	26	35	53	-	2.44	2.44	3.25	4.88	-	3.00	13.00	15.50	1.61	3.35	5.00	3.88	4.1	A+
		26	26	35	71	-	2.17	2.17	2.89	5.78	-	3.00	13.00	15.50	1.61	3.35	5.00	3.88	4.1	A+
		26	26	53	53	-	2.17	2.17	4.33	4.33	-	3.00	13.00	15.50	1.61	3.35	5.00	3.88	4.1	A+
		26	26	53	71	-	1.95	1.95	3.90	5.20	-	3.00	13.00	15.50	1.61	3.35	5.00	3.88	4.1	A+
		26	35	35	35	-	2.60	3.47	3.47	3.47	-	3.00	13.00	15.50	1.61	3.35	5.00	3.88	4.1	A+
		26	35	35	53	-	2.29	3.06	3.06	4.59	-	3.00	13.00	15.50	1.61	3.35	5.00	3.88	4.1	A+
		26	35	35	71	-	2.05	2.74	2.74	5.47	-	3.00	13.00	15.50	1.61	3.35	5.00	3.88	4.1	A+
		26	35	53	53	-	2.05	2.74	4.11	4.11	-	3.00	13.00	15.50	1.61	3.35	5.00	3.88	4.1	A+
		26	35	53	71	-	1.86	2.48	3.71	4.95	-	3.00	13.00	15.50	1.61	3.35	5.00	3.88	4.1	A+
26	53	53	53	-	1.86	3.71	3.71	3.71	-	3.00	13.00	15.50	1.61	3.35	5.00	3.88	4.1	A+		
35	35	35	35	-	3.25	3.25	3.25	3.25	-	3.00	13.00	15.50	1.61	3.35	5.00	3.88	4.1	A+		
35	35	35	53	-	2.89	2.89	2.89	4.33	-	3.00	13.00	15.50	1.61	3.35	5.00	3.88	4.1	A+		
35	35	35	71	-	2.60	2.60	2.60	5.20	-	3.00	13.00	15.50	1.61	3.35	5.00	3.88	4.1	A+		
35	35	53	53	-	2.60	2.60	3.90	3.90	-	3.00	13.00	15.50	1.61	3.35	5.00	3.88	4.1	A+		

Energy Class = EU Delegated Regulation No. 626/2011 on the new labelling indicating the energy consumption of air conditioners.
 SCOP = EU Regulation No. 206/2012 - - Value measured according to the harmonized standard EN14825.
 COP = Value measured according to the harmonized standard EN14511.

R32 COOLING COMBINATIONS WITH DHW TANK

Outdoor units	Combinations				Rated capacity (kW)				Total DHW yield (kW)			Total cooling performance (kW)			Absorbed power (kW)		
	Unit A	Unit B	Unit C	Unit D	Unit A	Unit B	Unit C	Unit D	Min	Nom	Max	Min	Nom	Max	Min	Nom	Max
MCKGWM 1002 Z3W	MWTGM 200 Z4W	26	-	-	4.20	2.60	-	-	2.20	4.20	4.60	2.20	2.60	3.00	1.60	2.30	3.50
		35	-	-	4.20	3.50	-	-	2.20	4.20	4.60	2.20	3.50	4.00	1.60	2.40	3.50
		53	-	-	4.20	5.25	-	-	2.20	4.20	4.60	2.20	5.25	5.80	1.60	2.40	3.50
		71	-	-	4.20	7.10	-	-	2.20	4.20	4.60	2.20	7.10	8.80	1.60	3.00	4.60
		26	26	-	4.20	2.60	2.60	-	2.20	4.20	4.60	2.60	5.20	6.50	1.60	2.70	5.00
		26	35	-	4.20	2.60	3.50	-	2.20	4.20	4.60	2.60	6.10	7.50	1.60	3.10	5.00
		26	53	-	4.20	2.60	5.25	-	2.20	4.20	4.60	2.60	7.85	9.00	1.60	3.20	5.00
		26	71	-	4.20	2.60	7.10	-	2.20	4.20	4.60	2.60	9.70	11.00	1.60	3.40	5.10
		35	35	-	4.20	3.50	3.50	-	2.20	4.20	4.60	2.60	7.00	9.20	1.60	3.20	5.00
		35	53	-	4.20	3.50	5.25	-	2.20	4.20	4.60	2.60	8.75	10.00	1.60	3.20	5.00
		35	71	-	4.20	3.50	7.10	-	2.20	4.20	4.60	2.60	10.60	12.00	1.60	3.80	6.10
		53	53	-	4.20	5.25	5.25	-	2.20	4.20	4.60	2.60	10.50	12.00	1.60	3.80	6.10
		53	71	-	4.20	4.54	6.06	-	2.20	4.20	4.60	2.60	10.60	12.00	1.60	3.80	6.10
		26	26	26	4.20	2.60	2.60	2.60	2.20	4.20	4.60	2.60	7.80	10.00	1.60	3.20	5.00
		26	26	35	4.20	2.60	2.60	3.50	2.20	4.20	4.60	2.60	8.70	11.00	1.60	3.40	5.10
		26	26	53	4.20	2.60	2.60	5.25	2.20	4.20	4.60	2.60	10.45	12.00	1.60	3.80	6.10
		26	26	71	4.20	2.27	2.27	6.06	2.20	4.20	4.60	2.60	10.60	12.00	1.60	3.80	6.10
		26	35	35	4.20	2.60	3.50	3.50	2.20	4.20	4.60	2.60	9.60	11.00	1.60	3.80	6.10
		26	35	53	4.20	2.45	3.26	4.89	2.20	4.20	4.60	2.60	10.60	12.00	1.60	3.80	6.10
		35	35	35	4.20	3.50	3.50	3.50	2.20	4.20	4.60	2.60	10.50	12.00	1.60	3.80	6.10
35	35	53	4.20	3.03	3.03	4.54	2.20	4.20	4.60	2.60	10.60	12.00	1.60	3.80	6.10		

Outdoor units	Combinations				Rated capacity (kW)					Total DHW yield (kW)			Total cooling performance (kW)			Absorbed power (kW)			
	Unit A	Unit B	Unit C	Unit D	Unit E	Unit A	Unit B	Unit C	Unit D	Unit E	Min	Nom	Max	Min	Nom	Max	Min	Nom	Max
MCKGWM 1202 Z4W	MWTGM 200 Z4W	26	-	-	-	4.20	2.60	-	-	-	2.20	4.20	4.60	2.20	2.60	3.00	1.60	2.30	3.50
		35	-	-	-	4.20	3.50	-	-	-	2.20	4.20	4.60	2.20	3.50	4.00	1.60	2.40	3.50
		53	-	-	-	4.20	5.25	-	-	-	2.20	4.20	4.60	2.20	5.25	5.80	1.60	2.40	3.50
		71	-	-	-	4.20	7.10	-	-	-	2.20	4.20	4.60	2.20	7.10	8.80	1.60	3.00	4.60
		26	35	-	-	4.20	2.60	3.50	-	-	2.20	4.20	4.60	2.60	6.10	7.50	1.60	3.10	6.10
		26	53	-	-	4.20	2.60	5.25	-	-	2.20	4.20	4.60	2.60	7.85	9.00	1.60	3.40	6.10
		26	71	-	-	4.20	2.60	7.10	-	-	2.20	4.20	4.60	2.60	9.70	11.00	1.60	4.20	6.10
		35	35	-	-	4.20	3.50	3.50	-	-	2.20	4.20	4.60	2.60	7.00	9.20	1.60	3.20	6.10
		35	53	-	-	4.20	3.50	5.25	-	-	2.20	4.20	4.60	2.60	8.75	10.00	1.60	3.80	6.10
		35	71	-	-	4.20	3.50	7.10	-	-	2.20	4.20	4.60	2.60	10.60	12.00	1.60	4.20	6.10
		53	53	-	-	4.20	5.25	5.25	-	-	2.20	4.20	4.60	2.60	10.50	12.00	1.60	4.20	6.10
		53	71	-	-	4.20	5.19	6.91	-	-	2.20	4.20	4.60	2.60	12.10	12.00	1.60	4.20	6.10
		26	26	26	-	4.20	2.60	2.60	2.60	-	2.20	4.20	4.60	2.60	7.80	10.00	1.60	3.60	6.10
		26	26	35	-	4.20	2.60	2.60	3.50	-	2.20	4.20	4.60	2.60	8.70	11.00	1.60	4.20	6.10
		26	26	53	-	4.20	2.60	2.60	5.25	-	2.20	4.20	4.60	2.60	10.45	13.02	1.60	3.80	6.10
		26	26	71	-	4.20	2.59	2.59	6.91	-	2.20	4.20	4.60	2.60	12.10	15.20	1.60	4.20	6.10
		26	35	35	-	4.20	2.60	3.50	3.50	-	2.20	4.20	4.60	2.60	9.60	11.94	1.60	3.80	6.10
		26	35	53	-	4.20	2.60	3.50	5.25	-	2.20	4.20	4.60	2.60	11.35	14.11	1.60	4.20	6.10
		26	35	71	-	4.20	2.42	3.23	6.45	-	2.20	4.20	4.60	2.60	12.10	15.20	1.60	4.20	6.10
		26	53	53	-	4.20	2.42	4.84	4.84	-	2.20	4.20	4.60	2.60	12.10	15.20	1.60	4.20	6.10
		26	53	71	-	4.20	2.14	4.27	5.69	-	2.20	4.20	4.60	2.60	12.10	15.20	1.60	4.20	6.10
		35	35	35	-	4.20	3.50	3.50	3.50	-	2.20	4.20	4.60	2.60	10.50	13.02	1.60	3.80	6.10
		35	35	53	-	4.20	3.46	3.46	5.19	-	2.20	4.20	4.60	2.60	12.10	15.20	1.60	4.20	6.10
		35	35	71	-	4.20	3.03	3.03	6.05	-	2.20	4.20	4.60	2.60	12.10	15.20	1.60	4.20	6.10
		35	53	53	-	4.20	3.03	4.54	4.54	-	2.20	4.20	4.60	2.60	12.10	15.20	1.60	4.20	6.10
		26	26	26	26	4.20	2.60	2.60	2.60	2.60	2.20	4.20	4.60	2.60	10.40	13.02	1.60	4.20	6.10
		26	26	26	35	4.20	2.60	2.60	2.60	3.50	2.20	4.20	4.60	2.60	11.30	14.11	1.60	4.20	6.10
		26	26	26	53	4.20	2.42	2.42	2.42	4.84	2.20	4.20	4.60	2.60	12.10	15.20	1.60	4.20	6.10
		26	26	26	71	4.20	2.14	2.14	2.14	5.69	2.20	4.20	4.60	2.60	12.10	15.20	1.60	4.20	6.10
		26	26	35	35	4.20	2.59	2.59	3.46	3.46	2.20	4.20	4.60	2.60	12.10	15.20	1.60	4.20	6.10
		26	26	35	53	4.20	2.27	2.27	3.03	4.54	2.20	4.20	4.60	2.60	12.10	15.20	1.60	4.20	6.10
		26	35	35	35	4.20	2.42	3.23	3.23	3.23	2.20	4.20	4.60	2.60	12.10	15.20	1.60	4.20	6.10
		26	35	35	53	4.20	2.14	2.85	2.85	4.27	2.20	4.20	4.60	2.60	12.10	15.20	1.60	4.20	6.10
		35	35	35	35	4.20	3.03	3.03	3.03	3.03	2.20	4.20	4.60	2.60	12.10	15.20	1.60	4.20	6.10

R32 HEATING COMBINATIONS WITH DHW TANK

Outdoor units	Combinations				Rated capacity (kW)				Total DHW yield (kW)			Total heating capacity (kW)			Absorbed power (kW)			
	Unit A	Unit B	Unit C	Unit D	Unit A	Unit B	Unit C	Unit D	Min	Nom	Max	Min	Nom	Max	Min	Nom	Max	
MCKGWM 1002 Z3W	MWTGM 200 Z4W	26	-	-	4.20	2.80	-	-	2.20	4.20	4.60	2.60	2.80	3.20	1.61	2.30	3.80	
		35	-	-	4.20	3.80	-	-	2.20	4.20	4.60	3.00	3.80	4.00	1.61	2.60	4.00	
		53	-	-	4.20	5.60	-	-	2.20	4.20	4.60	3.00	5.60	6.00	1.61	2.90	4.80	
		71	-	-	4.20	8.20	-	-	2.20	4.20	4.60	3.00	8.20	9.00	1.61	3.04	5.00	
		26	26	-	4.20	2.80	2.80	-	-	2.20	4.20	4.60	3.00	5.60	7.00	1.61	2.70	5.10
		26	35	-	4.20	2.80	3.80	-	-	2.20	4.20	4.60	3.00	6.60	8.16	1.61	3.10	5.30
		26	53	-	4.00	2.67	5.33	-	-	2.20	4.00	4.60	3.00	8.00	10.50	1.61	3.60	5.70
		26	71	-	3.32	2.21	6.47	-	-	2.20	3.32	4.60	3.00	8.68	12.83	1.61	3.84	6.50
		35	35	-	4.20	3.80	3.80	-	-	2.20	4.20	4.60	3.00	7.60	9.33	1.61	3.40	5.50
		35	53	-	3.71	3.35	4.94	-	-	2.20	3.71	4.60	3.00	8.29	11.66	1.61	3.70	6.30
		35	71	-	3.11	2.81	6.07	-	-	2.20	3.11	4.60	3.00	8.89	14.00	1.61	3.84	6.50
		53	53	-	3.27	4.36	4.36	-	-	2.20	3.27	4.60	3.00	8.73	14.00	1.61	3.84	6.50
		53	71	-	3.11	3.81	5.08	-	-	2.20	3.11	4.60	3.00	8.89	14.00	1.61	3.84	6.50
		26	26	26	4.00	2.67	2.67	2.67	-	2.20	4.00	4.60	3.00	8.00	10.50	1.61	3.60	5.70
		26	26	35	3.71	2.47	2.47	3.35	-	2.20	3.71	4.60	3.00	8.29	11.66	1.61	3.70	6.30
		26	26	53	3.27	2.18	2.18	4.36	-	2.20	3.27	4.60	3.00	8.73	14.00	1.61	3.84	6.50
		26	26	71	3.11	1.90	1.90	5.08	-	2.20	3.11	4.60	3.00	8.89	14.00	1.61	3.84	6.50
		26	35	35	3.45	2.30	3.12	3.12	-	2.20	3.45	4.60	3.00	8.55	12.83	1.61	3.84	6.50
		26	35	53	3.11	2.05	2.74	4.10	-	2.20	3.11	4.60	3.00	8.89	14.00	1.61	3.84	6.50
		35	35	35	3.23	2.92	2.92	2.92	-	2.20	3.23	4.60	3.00	8.77	14.00	1.61	3.84	6.50
35	35	53	3.11	2.54	2.54	3.81	-	2.20	3.11	4.60	3.00	8.89	14.00	1.61	3.84	6.50		

Outdoor units	Combinations					Rated capacity (kW)					Total DHW yield (kW)			Total heating capacity (kW)			Absorbed power (kW)			
	Unit A	Unit B	Unit C	Unit D	Unit E	Unit A	Unit B	Unit C	Unit D	Unit E	Min	Nom	Max	Min	Nom	Max	Min	Nom	Max	
MCKGWM 1202 Z4W	MWTGM 200 Z4W	26	-	-	-	4.20	2.80	-	-	-	2.20	4.20	4.60	2.60	2.80	3.20	1.61	2.30	3.80	
		35	-	-	-	4.20	3.80	-	-	-	2.20	4.20	4.60	3.00	3.80	4.00	1.61	2.60	4.00	
		53	-	-	-	4.20	5.60	-	-	-	2.20	4.20	4.60	3.00	5.60	6.00	1.61	2.90	4.80	
		71	-	-	-	4.20	8.20	-	-	-	2.20	4.20	4.60	3.00	8.20	9.00	1.61	3.04	5.00	
		26	35	-	-	4.20	2.80	3.80	-	-	-	2.20	4.20	4.60	3.00	6.60	7.75	1.61	3.10	5.70
		26	53	-	-	4.20	2.80	5.60	-	-	-	2.20	4.20	4.60	3.00	8.40	9.96	1.61	3.40	6.00
		26	71	-	-	3.59	2.39	7.01	-	-	-	2.20	3.59	4.60	3.00	9.41	12.17	1.61	3.60	6.00
		35	35	-	-	4.20	3.80	3.80	-	-	-	2.20	4.20	4.60	3.00	7.60	8.85	1.61	3.40	6.00
		35	53	-	-	4.01	3.63	5.35	-	-	-	2.20	4.01	4.60	3.00	8.99	11.07	1.61	3.60	6.00
		35	71	-	-	3.37	3.05	6.58	-	-	-	2.20	3.37	4.60	3.00	9.63	13.28	1.61	3.60	6.00
		53	53	-	-	3.55	4.73	4.73	-	-	-	2.20	3.55	4.60	3.00	9.45	13.28	1.61	3.60	6.00
		53	71	-	-	3.17	4.21	5.61	-	-	-	2.20	3.17	4.60	3.00	9.83	15.50	1.61	3.99	6.50
		26	26	26	-	4.20	2.80	2.80	2.80	-	-	2.20	4.20	4.60	3.00	8.40	9.96	1.61	3.40	6.00
		26	26	35	-	4.01	2.68	2.68	3.63	-	-	2.20	4.01	4.60	3.00	8.99	11.07	1.61	3.60	6.00
		26	26	53	-	3.55	2.36	2.36	4.73	-	-	2.20	3.55	4.60	3.00	9.45	13.28	1.61	3.60	6.00
		26	26	71	-	3.17	2.11	2.11	5.61	-	-	2.20	3.17	4.60	3.00	9.83	15.50	1.61	3.99	6.50
		26	35	35	-	3.74	2.49	3.38	3.38	-	-	2.20	3.74	4.60	3.00	9.26	12.17	1.61	3.60	6.00
		26	35	53	-	3.33	2.22	3.01	4.44	-	-	2.20	3.33	4.60	3.00	9.67	14.39	1.61	3.99	6.50
		26	35	71	-	3.17	1.97	2.62	5.24	-	-	2.20	3.17	4.60	3.00	9.83	15.50	1.61	3.99	6.50
		26	53	53	-	3.17	1.97	3.93	3.93	-	-	2.20	3.17	4.60	3.00	9.83	15.50	1.61	3.99	6.50
		26	53	71	-	3.17	1.73	3.47	4.62	-	-	2.20	3.17	4.60	3.00	9.83	15.50	1.61	3.99	6.50
		35	35	35	-	3.50	3.17	3.17	3.17	-	-	2.20	3.50	4.60	3.00	9.50	13.28	1.61	3.60	6.00
		35	35	53	-	3.17	2.81	2.81	4.21	-	-	2.20	3.17	4.60	3.00	9.83	15.50	1.61	3.99	6.50
		35	35	71	-	3.17	2.46	2.46	4.91	-	-	2.20	3.17	4.60	3.00	9.83	15.50	1.61	3.99	6.50
		35	53	53	-	3.17	2.46	3.68	3.68	-	-	2.20	3.17	4.60	3.00	9.83	15.50	1.61	3.99	6.50
		26	26	26	26	3.55	2.36	2.36	2.36	2.36	-	2.20	3.55	4.60	3.00	9.45	14.00	1.61	3.80	6.30
		26	26	26	35	3.33	2.22	2.22	2.22	3.01	-	2.20	3.33	4.60	3.00	9.67	14.39	1.61	3.99	6.50
		26	26	26	53	3.17	1.97	1.97	3.93	3.93	-	2.20	3.17	4.60	3.00	9.83	15.50	1.61	3.99	6.50
		26	26	26	71	3.17	1.73	1.73	4.62	4.62	-	2.20	3.17	4.60	3.00	9.83	15.50	1.61	3.99	6.50
		26	26	35	35	3.17	2.11	2.11	2.81	2.81	-	2.20	3.17	4.60	3.00	9.83	15.50	1.61	3.99	6.50
		26	26	35	53	3.17	1.84	1.84	2.46	3.68	-	2.20	3.17	4.60	3.00	9.83	15.50	1.61	3.99	6.50
		26	35	35	35	3.17	1.97	2.62	2.62	2.62	-	2.20	3.17	4.60	3.00	9.83	15.50	1.61	3.99	6.50
		26	35	35	53	3.17	1.73	2.31	2.31	3.47	-	2.20	3.17	4.60	3.00	9.83	15.50	1.61	3.99	6.50
		35	35	35	35	3.17	2.46	2.46	2.46	2.46	-	2.20	3.17	4.60	3.00	9.83	15.50	1.61	3.99	6.50



VRF SYSTEMS

MW MINI, MW 2-PIPE, MW 3-PIPE

57	MW MINI SYSTEM
59	> OUTDOOR UNITS
61	MW 2-PIPE SYSTEM ANTI CORROSION
66	> OUTDOOR UNITS
68	> COMBINATIONS
73	MW 3-PIPE SYSTEM HEAT RECOVERY
84	> OUTDOOR UNITS
86	> COMBINATIONS
90	> FLOW CONTROLLERS
91	> HYDRONIC MODULE



MW MINI SYSTEM

COMPACT OUTDOOR UNITS



10.00 kW	12.10 kW	14.10 kW
1-Phase	1-Phase	1-Phase
M-VMC-OV-100-NG	M-VMC-OV-121-NG	M-VMC-OV-141-NG

SLIM OUTDOOR UNITS



16.00 kW	22.40 kW	28.00 kW	33.50 kW
3-Phase	3-Phase	3-Phase	3-Phase
M-VM-OV-160-SG	M-VS-OV-224-SG	M-VS-OV-280-SG	M-VS-OV-335-SG

INDOOR UNITS

Applicable indoor units
for air-to-air operation
on page. 93

MW MINI COMPACT & SLIM IS COMPOSED OF 7 SINGLE OUTDOOR UNITS TO WHICH MAX 20 INDOOR UNITS CAN BE CONNECTED

1-PHASE, SINGLE FAN: 3 MODELS

The 1-Phase outdoor units with horizontal air discharge are available in 10.00 kW, 12.10 kW and 14.10 kW models.

All the compressors of the 1-Phase models are Rotary DC Inverter and Inverter fans.

3-PHASE, DOUBLE FAN: 4 MODELS

The 3-Phase outdoor units with horizontal air discharge are available in 16.00 kW, 22.40 kW, 28.00 kW and 33.50 kW models.

Rotary DC Inverter compressor for the 16.00 kW and 22.40 kW models.
Scroll Inverter compressor for the 28.00 kW and 33.50 kW models.

CAPACITY AND NUMBER OF CONNECTABLE INDOOR UNITS

Model	Min~Max power of connectable I.U.	Min~Max number of connectable I.U.
M-VMC-OV-100-NG	50~135%	1~5
M-VMC-OV-121-NG	50~135%	1~6
M-VMC-OV-141-NG	50~135%	1~8
M-VM-OV-160-SG	50~135%	1~9
M-VS-OV-224-SG	50~135%	1~13
M-VS-OV-280-SG	50~135%	1~17
M-VS-OV-335-SG	50~135%	1~20

OPERATING RANGE

up to

52°C

in cooling

down to

-20°C

in heating

MAXIMUM COMPACTNESS FOR ALL OUTDOOR UNITS

COMPACT
10.00 - 12.10 - 14.10 kW



L 980 x H 790 x D 360 (mm) 10~12.1 kW
L 940 x H 820 x D 460 (mm) 14.1 kW

SLIM
16.00 - 22.40 - 28.00 - 33.50 kW



L 900 x H 1345 x D 340 (mm) 16 kW
L 940 x H 1430 x D 320 (mm) 22.4 kW
L 940 x H 1615 x D 460 (mm) 28~33.5 kW

COMPACT OUTDOOR UNITS

3 REFRIGERANT CAPACITIES

10.00 - 12.10 - 14.10 kW

R410A

Refrigerant gas

GOLD FIN PROTECTION

USE IN SINGLE MODE

(not in combination)

COMPACT DESIGN

COOLING OPERATING RANGE

-5~+52° C

HEATING OPERATING RANGE

-20~+27° C



M-VMC-OV-100-NG
M-VMC-OV-121-NG
M-VMC-OV-141-NG

Model			M-VMC-OV-100-NG	M-VMC-OV-121-NG	M-VMC-OV-141-NG
Nominal Data					
Rated capacity		kW	10.00	12.10	14.10
Nominal absorbed power	Cooling	kW	2.70	3.50	3.92
Energy efficiency coefficient (nominal)		EER1	3.70	3.51	3.60
Rated capacity		kW	11.00	13.00	16.00
Nominal absorbed power	Heating	kW	2.50	2.70	4.16
Energy performance coefficient (nominal)		COP1	4.40	4.81	3.85
Seasonal Data					
Seasonal energy efficiency index	Cooling	SEER2	6.60	7.28	6.76
Seasonal performance coefficient	Heating	SCOP2	3.80	4.45	3.67
Seasonal energy efficiency (ηs)		%	149	175	143.80
Electrical Data					
Power supply		Ph-V-Hz		1-220~240V-50Hz	
Maximum current		A	22.40	24.00	35.80
Refrigerant Circuit Data					
Refrigerant ³		type (GWP)		R410A (2088)	
Q.ty of refrigerant pre-charge ⁴ (tons of CO2 equivalent)		Kg	1.8 (3.76)	2 (4.18)	3.3 (6.89)
Compressor		nb. / type		1 / Rotary DC Inverter	
Piping diameter	Liquid	mm (inch)	9.52 (3/8")	9.52 (3/8")	9.52 (3/8")
	Gas	mm (inch)	15.9 (5/8")	15.9 (5/8")	15.9 (5/8")
Product Specifications					
Dimensions	WxHxD	mm	980x790x360	980x790x360	940x820x460
Net weight		Kg	80	85	98
Sound power level	max	dB(A)	69	70	73
Sound pressure level at 1 m	max	dB(A)	-	-	-
Volume of air treated	max	m ³ /h	4000	4400	5200
Operating range (outdoor temperature)	Cooling	°C	-5~52	-5~52	-5~52
	Heating	°C	-20~27	-20~27	-20~27
Connectable indoor units (min - max)		nb.	1 - 5	1 - 6	1 - 8
Capacity of connectable indoor units		%		50 ~ 135	

1. Value measured according to the harmonized standard EN14511.

2. EU Regulation No. 206/2012 - N.2281/2016 - Value measured according to the harmonized standard EN14825.

3. Refrigerant leakage contributes to climate change. If released into the atmosphere, refrigerants with a lower global warming potential (GWP) contribute less to global warming than those with a higher GWP. This appliance contains a refrigerant with a GWP of 2088.

If 1 kg of this refrigerant were released into the atmosphere, therefore, the impact on global warming would be 2088 times higher than 1 kg of CO₂, over a period of 100 years.

Under no circumstances should the user attempt to intervene on the refrigerant circuit or disassemble the product. If necessary, always contact qualified personnel.

4. To calculate the additional refrigerant charge, refer to the labels located inside and outside the unit.

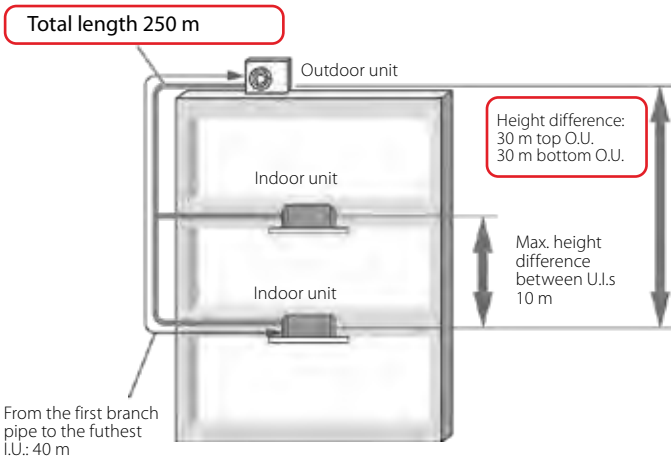

ALUMINIUM LOUVERS WITH ANTI-CORROSION COATING (GOLD FIN)

The louvers' coating lasts over time and ensures greater resistance to salt corrosion.

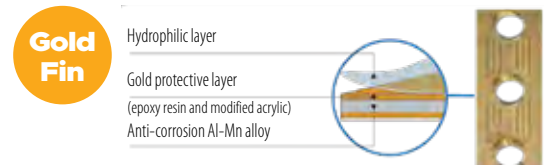

SLIM OUTDOOR UNITS

4 REFRIGERANT CAPACITIES

16.00 - 22.40 - 28.00 - 33.50 kW

R410A

Refrigerant gas

GOLD FIN PROTECTION

USE IN SINGLE MODE
(not in combination)

COMPACT DESIGN

COOLING OPERATING RANGE
-5~+52° C

HEATING OPERATION RANGE

-20~+27° C



M-VM-OV-160-SG
M-VS-OV-224-SG
M-VS-OV-280-SG
M-VS-OV-335-SG

Model	M-VM-OV-160-SG		M-VS-OV-224-SG		M-VS-OV-280-SG		M-VS-OV-335-SG		
Nominal Data									
Rated capacity	Cooling	kW	16.00	22.40	28.00	33.50			
Nominal absorbed power		kW	4.75	6.12	7.78	9.57			
Energy efficiency coefficient (nominal)		EER ¹	3.37	3.66	3.60	3.50			
Rated capacity	Heating	kW	18.00	24.00	30.00	35.00			
Nominal absorbed power		kW	4.65	4.90	6.12	7.14			
Energy performance coefficient (nominal)		COP ¹	3.87	4.90	4.90	4.90			
Seasonal Data									
Seasonal energy efficiency index	Cooling	SEER ²	6.96	7.27	6.98	7.10			
Seasonal performance coefficient	Heating	SCOP ²	4.04	4.08	3.92	4.06			
Seasonal energy efficiency (ηs)		%	158.60	160.20	153.80	159.40			
Electrical Data									
Power supply	Ph-V-Hz		3-380~415V-50Hz						
Maximum current	A		12.50	17.20	24.00	24.50			
Refrigerant Circuit Data									
Refrigerant ³	type (GWP)		R410A (2088)						
Q.ty of refrigerant pre-charge ⁴ (tons of CO2 equivalent)	Kg		3.3 (6.89)	5.5 (11.48)	7.1 (14.82)	8 (16.7)			
Compressor	nb. / type		1 / Rotary DC Inverter			1 / Scroll DC Inverter			
Piping diameter	Liquid	mm (inch)	9.52 (3/8")	9.52 (3/8")	9.52 (3/8")	12.7 (1/2")			
	Gas	mm (inch)	19.05 (3/4")	19.05 (3/4")	22.2 (7/8")	25.4 (1")			
Product Specifications									
Dimensions	WxHxD		mm	900x1345x340	940x1430x320	940x1615x460	940x1615x460		
Net weight			Kg	122	133	166	177		
Sound power level	max		dB(A)	69	74	74	76		
Sound pressure level at 1 m	max		dB(A)	-	-	-	-		
Volume of air treated	max		m ³ /h	6000	8000	11000	11000		
Operating range (outdoor temperature)	Cooling		°C	-5~-52	-5~-52	-5~-52	-5~-52		
	Heating		°C	-20~-27	-20~-27	-20~-27	-20~-27		
Connectable indoor units (min - max)			nb.	1 - 9	1 - 13	1 - 17	1 - 20		
Capacity of connectable indoor units			%	50 ~ 135					

1. Value measured according to the harmonized standard EN14511.

2. EU Regulation No. 206/2012 - N.2281/2016 - Value measured according to the harmonized standard EN14825.

3. Refrigerant leakage contributes to climate change. If released into the atmosphere, refrigerants with a lower global warming potential (GWP) contribute less to global warming than those with a higher GWP. This appliance contains a refrigerant with a GWP of 2088. If 1 kg of this refrigerant were released into the atmosphere, therefore, the impact on global warming would be 2088 times higher than 1 kg of CO2, over a period of 100 years.

Under no circumstances should the user attempt to intervene on the refrigerant circuit or disassemble the product. If necessary, always contact qualified personnel.

4. To calculate the additional refrigerant charge, refer to the labels located inside and outside the unit.

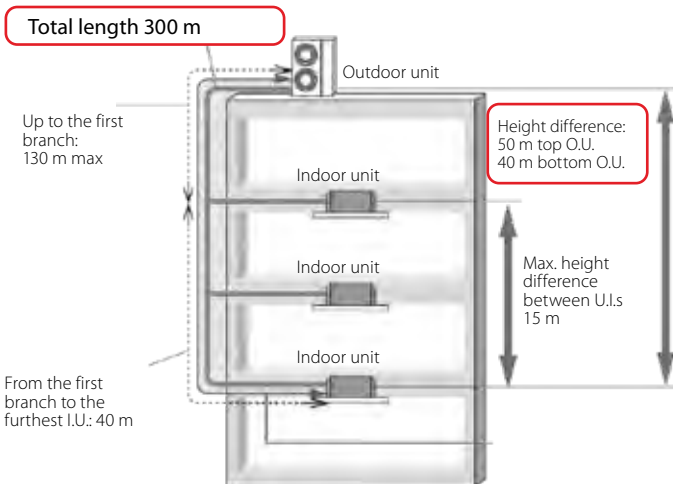

ALUMINIUM LOUVERS WITH ANTI-CORROSION COATING (GOLD FIN)

The louvers' coating lasts over time and ensures greater resistance to salt corrosion.



Hydrophilic layer
Gold protective layer
(epoxy resin and modified acrylic)
Anti-corrosion Al-Mn alloy

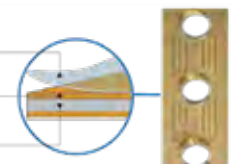

THE MW 2-PIPE SYSTEM ANTI-CORROSION IN INDIVIDUAL OR MODULAR USE

OUTDOOR UNITS



22.40 kW	28.00 kW	33.50 kW
8HP	10HP	12HP
M-VA-OV-224-SG	M-VA-OV-280-SG	M-VA-OV-335-SG



40.00 kW	45.00 kW	50.40 kW	56.00 kW	61.50 kW
14HP	16HP	18HP	20HP	22HP
M-VA-OV-400-SG	M-VA-OV-450-SG	M-VA-OV-500-SG	M-VA-OV-560-SG	M-VA-OV-615-SG

INDOOR UNITS

Applicable indoor units
for air-to-air operation
on page. 93



THE MW 2-PIPE ANTI-CORROSION CONSISTS OF 8 INDIVIDUAL OUTDOOR UNITS. IN COMBINATION IT REACHES A MAXIMUM OUTPUT OF 246 KW TO WHICH UP TO 80 INDOOR UNITS CAN BE CONNECTED

8 THREE-PHASE MODELS

The 3-phase outdoor units with vertical air discharge are available in models from 22.40 kW up to 61.50 kW. The maximum power of the combined outdoor units reaches 246 kW, the highest value in the industry.

All compressors of the 3-Phase models are Scroll DC Inverter.

The MW 2-PIPE ANTI-CORROSION system can connect up to a maximum of 80 indoor units.

POWER AND NUMBER OF CONNECTABLE INDOOR UNITS

Model	Min~Max power of connectable I.U.	Min~Max number of connectable I.U.
M-VA-OV-224-SG	50~135%	1~13
M-VA-OV-280-SG	50~135%	1~16
M-VA-OV-335-SG	50~135%	1~19
M-VA-OV-400-SG	50~135%	1~23
M-VA-OV-450-SG	50~135%	1~26
M-VA-OV-500-SG	50~135%	1~29
M-VA-OV-560-SG	50~135%	1~33
M-VA-OV-615-SG	50~135%	1~36

MAXIMUM COMPACTNESS FOR ALL OUTDOOR UNITS

22.40 - 28.00 - 33.50 kW



L 930 x H 1690 x D 775 (mm)

40.00 - 45.00 - 50.40 - 56.00 - 61.50 kW



L 1340 x H 1690 x D 775 (mm)

SPECIAL ANTI-CORROSION TREATMENT

With the special anti-corrosion treatment of the outdoor units, the application possibilities are increased, especially in coastal areas where the air is richer in salt and humidity, and in industrial areas where high concentrations of chemical substances are present.

The test carried out with neutral salt spray (H) found effective increases in performance compared to untreated models.

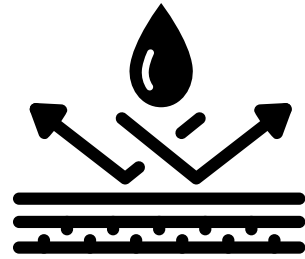

GRILLES

The grilles receive a phosphating and electrophoresis treatment and are coated with highly weather-resistant powder.

+100% anti-corrosion capacity compared to a standard model.

GAS-LIQUID SEPARATOR

The surface of the pressure vessel adopts phosphorizing treatment and is coated with high weather-resistant powder.

+ 400% anti-corrosion capacity compared to a standard model.

HEAT EXCHANGER

The heat exchanger features black aluminum fins that are resistant to acids and corrosion. State-of-the-art anti-corrosion treatment.

+ 33% anti-corrosion capacity compared to a standard model.

ZINC-NICKEL FASTENERS

The body uses zinc-nickel alloy screws to improve anti-corrosion performance. These screws withstand neutral salt spray test for 500 hours without rusting.

+400% anti-corrosion capacity compared to normal galvanized screws.

PRINTED CIRCUIT BOARD

The surface of the controller is coated with a special protective material, acting against humidity, mold and corrosion.

+ 400% anti-corrosion capacity compared to a standard model.

BODY

The surface of the roofing sheet metal is treated with highly weather-resistant powder.

+ 100% anti-corrosion capacity compared to a standard model.

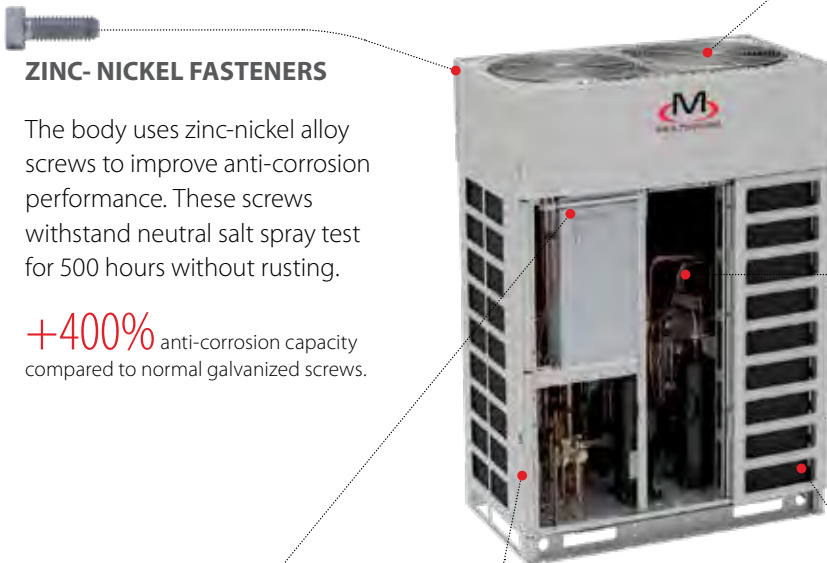

EXCELLENT PERFORMANCE

The MW 2-PIPE ANTI-CORROSION systems are characterised by high installation flexibility, thanks to the possibility of connecting internal units of different types.

The wide range of outdoor units in terms of power, modularity and dimensions also allows you to choose the optimal solution capable of meeting the requirements of occupied space, weight and handling in each application.

Possibility of using classic heat recovery units (ERV), or combined with post-treatment batteries (ERV+DX), for the introduction of renewal air. The recovery units are equipped with high efficiency filters.

Through centralized controls, Wi-Fi interfaces and multiple protocol gateways, it is possible to manage large systems remotely and from a single terminal.



ENERGY EFFICIENCY

- High efficiency low temperature enthalpy addition technology.
- New heat exchanger design.
- Smart control.
- Intelligent cooling and heating technology.
- Noise control technology.

RELIABLE AND STABLE

- Multiple corrosion protection.
- CAN+communication technology.
- Multiple safety protection.
- Self-adapting drive control technology.
- Oil quality control technology.
- Oil circuit management technology.
- Compact structure.
- Very wide operating range: thanks to its modularity, the system can be adapted to the power required by different installations.

ADAPTABLE AND FLEXIBLE

- Compact design.
- Fan static pressure: up to 110 Pa, the highest on the market.
- Very high splitting limits and height difference between units: make the system adaptable to various types of installation.
- Fast installation.
- High degree of installation adaptability.

Operating ranges of outdoor units

The **MW 2-PIPE ANTI-CORROSION** system features a very wide external temperature operating range, ensuring new design flexibility.

up to

55°C

in cooling

down to

-30°C

in heating



COOLING MODE

Outdoor temperature from -15° to 55° C



HEATING MODE

Outdoor temperature from -30° to 24° C



OUTDOOR UNITS

3 REFRIGERANT CAPACITIES
22.40 - 28.00 - 33.50 kW

R410A
Refrigerant gas

DC Inverter compressors guarantee total reliability thanks to high energy efficiency and silence. In addition, they allow a reduction in vibrations and accurate control of the operating frequency.



OPERATION RANGE

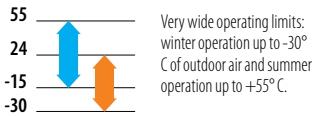

M-VA-OV-224-SG
M-VA-OV-280-SG
M-VA-OV-335-SG

Model			M-VA-OV-224-SG	M-VA-OV-280-SG	M-VA-OV-335-SG
Power	HP		8	10	12
Nominal Data					
Rated capacity	Cooling	kW	22.40	28.00	33.50
Nominal absorbed power		kW	4.99	6.26	8.00
Energy efficiency coefficient (nominal)		EER ¹	4.49	4.47	4.19
Rated capacity	Heating	kW	25.00	31.50	37.50
Nominal absorbed power		kW	4.85	7.39	8.68
Energy performance coefficient (nominal)		COP ¹	5.15	4.26	4.32
Seasonal Data					
Seasonal energy efficiency index	Cooling	SEER ²	7.10	6.59	6.31
Seasonal performance coefficient	Heating	SCOP ²	4.62	4.80	4.40
Seasonal energy efficiency (ns)		%	181.80	189.00	173.00
Electrical Data					
Power supply	Ph-V-Hz		3-380~415V-50Hz		
Maximum current	A		23.00	23.50	24.10
Refrigerant Circuit Data					
Refrigerant ³	type (GWP)		R410A (2088)		
Q.ty of refrigerant pre-charge ⁴ (tons of CO2 equivalent)	Kg		5.5 (11.48)	5.5 (11.48)	7.5 (15.66)
Compressor	nb. / type		1 / Scroll DC Inverter		
Piping diameter	Liquid	mm (inch)	9.52 (3/8")	9.52 (3/8")	12.7 (1/2")
	Gas	mm (inch)	19.05 (3/4")	22.2 (7/8")	25.4 (1")
Product Specifications					
Dimensions	WxHxD	mm	930x1690x775	930x1690x775	930x1690x775
Net weight	Kg		220	240	240
Sound power level	max	dB(A)	82	86	86
Sound pressure level at 1 m	max	dB(A)	56	57	59
Volume of air treated	max	m ³ /h	9750	10500	11100
Available static pressure	std/max	Pa	0/110	0/110	0/110
	Operating range (outdoor temperature)	Cooling	°C	-15~55	-15~55
	Heating	°C	-30~24	-30~24	-30~24
Connectable air-to-air indoor units (max)	nb.		13	16	19
Capacity of connectable air-to-air indoor units	%			50 ~ 135	

1. Value measured according to the harmonized standard EN14511.

2. EU Regulation No. 206/2012 -- Value measured according to the harmonized standard EN14825.

3. Refrigerant leakage contributes to climate change. If released into the atmosphere, refrigerants with a lower global warming potential (GWP) contribute less to global warming than those with a higher GWP. This appliance contains a refrigerant with a GWP of 2088. If 1 kg of this refrigerant were released into the atmosphere, therefore, the impact on global warming would be 2088 times higher than 1 kg of CO2, over a period of 100 years.

Under no circumstances should the user attempt to intervene on the refrigerant circuit or disassemble the product. If necessary, always contact qualified personnel.

4. To calculate the additional refrigerant charge, refer to the labels located inside and outside the unit.

OUTDOOR UNITS

5 REFRIGERANT CAPACITIES
40.00 - 45.00 - 50.40 - 56.00 - 61.50 kW

R410A
Refrigerant gas

DC Inverter compressors guarantee total reliability thanks to high energy efficiency and silence. In addition, they allow a reduction in vibrations and accurate control of the operating frequency.



OPERATION RANGE

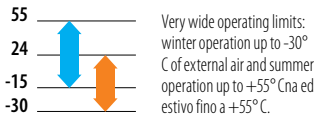

- M-VA-OV-400-SG
- M-VA-OV-450-SG
- M-VA-OV-500-SG
- M-VA-OV-560-SG
- M-VA-OV-615-SG

Model			M-VA-OV-400-SG	M-VA-OV-450-SG	M-VA-OV-500-SG	M-VA-OV-560-SG	M-VA-OV-615-SG
Power	HP		14	16	18	20	22
Nominal Data							
Rated capacity	Cooling	kW	40.00	45.00	50.40	56.00	61.50
Nominal absorbed power		kW	9.52	11.87	12.76	15.47	17.47
Energy efficiency coefficient (nominal)		EER ¹	4.20	3.79	3.95	3.62	3.52
Rated capacity	Heating	kW	45.00	50.00	56.50	63.00	69.00
Nominal absorbed power		kW	11.17	12.99	13.92	15.56	17.60
Energy performance coefficient (nominal)		COP ¹	4.03	3.85	4.06	4.05	3.92
Seasonal Data							
Seasonal energy efficiency index	Cooling	SEER ²	6.68	6.17	6.06	5.97	5.97
Seasonal performance coefficient	Heating	SCOP ²	4.80	4.84	4.19	4.11	4.11
Seasonal energy efficiency (ηs)		%	189.00	190.60	164.60	161.40	161.40
Electrical Data							
Power supply	Ph-V-Hz	3-380~415V-50Hz					
Maximum current	A	37.50	39.30	47.00	48.00	49.00	
Refrigerant Circuit Data							
Refrigerant ³	type (GWP)	R410A (2088)					
Q.ty of refrigerant pre-charge ⁴ (tons of CO2 equivalent)	Kg	7.5 (15.66)	7.5 (15.66)	8.3 (17.33)	8.3 (17.33)	8.3 (17.33)	
Compressor	nb. / type	1 / Scroll DC Inverter			2 / Scroll DC Inverter		
Piping diameter	Liquid	mm (inch)	12.7 (1/2")	12.7 (1/2")	15.9 (5/8")	15.9 (5/8")	15.9 (5/8")
	Gas	mm (inch)	25.4 (1")	28.6 (1-1/8")	28.6 (1-1/8")	28.6 (1-1/8")	28.6 (1-1/8")
Product Specifications							
Dimensions	WxHxD	mm	1340x1690x775	1340x1690x775	1340x1690x775	1340x1690x775	1340x1690x775
Net weight		Kg	300	300	350	350	355
Sound power level	max	dB(A)	90	93	93	94	94
Sound pressure level at 1 m	max	dB(A)	59	60	61	62	63
Volume of air treated	max	m ³ /h	13500	15400	16000	16500	16500
Available static pressure	std/max	Pa	0/110	0/110	0/110	0/110	0/110
Operating range (outdoor temperature)	Cooling	°C	-15~55	-15~55	-15~55	-15~55	-15~55
	Heating	°C	-30~24	-30~24	-30~24	-30~24	-30~24
Connectable air-to-air indoor units (max)	nb.		23	26	29	33	36
Capacity of connectable air-to-air indoor units	%		50 ~ 135				

1. Value measured according to the harmonized standard EN14511.

2. EU Regulation No. 206/2012 -- Value measured according to the harmonized standard EN14825.

3. Refrigerant leakage contributes to climate change. If released into the atmosphere, refrigerants with a lower global warming potential (GWP) contribute less to global warming than those with a higher GWP. This appliance contains a refrigerant with a GWP of 2088.

If 1 kg of this refrigerant were released into the atmosphere, therefore, the impact on global warming would be 2088 times higher than 1 kg of CO₂ over a period of 100 years.

Under no circumstances should the user attempt to intervene on the refrigerant circuit or disassemble the product. If necessary, always contact qualified personnel.

4. To calculate the additional refrigerant charge, refer to the labels located inside and outside the unit.

COMBINATIONS

Model			M-VA-OV-680-SG	M-VA-OV-730-SG	M-VA-OV-785-SG	M-VA-OV-850-SG
Power	HP		24	26	28	30
Combination			280+400	280+450	280+500	280+560
Rated capacity	Cooling	kW	68.00	73.00	78.40	84.00
Nominal absorbed power		kW	15.79	18.14	19.02	21.73
Energy efficiency coefficient (nominal)		EER ¹	4.31	4.02	4.12	3.86
Rated capacity	Heating	kW	76.50	81.50	88.00	94.50
Nominal absorbed power		kW	18.56	20.38	21.31	22.95
Energy performance coefficient (nominal)		COP ¹	4.12	4.00	4.13	4.12
Electrical Data						
Power supply	Ph-V-Hz		3-380~415V-50Hz			
Maximum current	A		61.00	62.80	70.50	71.50
Refrigerant Circuit Data						
Refrigerant ²	type (GWP)		R410A (2088)			
Qty. of refrigerant pre-charge ³ (tons of CO ₂ equivalent)	Kg		13 (27.14)	13 (27.14)	13.8 (28.81)	13.8 (28.81)
Compressor	nb. / type		2 / Scroll DC Inverter		3 / Scroll DC Inverter	
Piping diameter ⁴	Liquid	mm (inch)	15.9 (5/8")	19.05 (3/4")	19.05 (3/4")	19.05 (3/4")
	Gas	mm (inch)	28.6 (1-1/8")	31.8 (1-1/4")	31.8 (1-1/4")	31.8 (1-1/4")
Product Specifications						
Dimensions ⁵	WxHxD	mm	2370x1690x775	2370x1690x775	2370x1690x775	2370x1690x775
Net weight		Kg	520	520	570	570
Volume of air treated	max	m ³ /h	24000	25900	26500	27000
Available static pressure	std/max	Pa	0/110	0/110	0/110	0/110
Operating range (outdoor temperature)	Cooling	°C	-15~55	-15~55	-15~55	-15~55
	Heating	°C	-30~24	-30~24	-30~24	-30~24
Connectable air-to-air indoor units (max)	nb.		39	43	46	50
Capacity of connectable air-to-air indoor units	%		50 ~ 135			
Accessories						
Branch pipe kit for O.U. pairing	nb. / type		1 / DOS-68-MW-VA			

Model			M-VA-OV-1300-SG	M-VA-OV-1350-SG	M-VA-OV-1410-SG	M-VA-OV-1460-SG
Power	HP		46	48	50	52
Combination			280+450+560	280+450+615	335+450+615	280+560+615
Rated capacity	Cooling	kW	129.00	134.50	140.00	145.50
Nominal absorbed power		kW	33.61	35.61	37.34	36.50
Energy efficiency coefficient (nominal)		EER ¹	3.84	3.78	3.75	3.99
Rated capacity	Heating	kW	144.50	150.50	156.50	163.50
Nominal absorbed power		kW	35.94	37.98	39.27	38.91
Energy performance coefficient (nominal)		COP ¹	4.02	3.96	3.99	4.20
Electrical Data						
Power supply	Ph-V-Hz		3-380~415-50			
Maximum current	A		110.80	111.80	112.40	119.50
Refrigerant Circuit Data						
Refrigerant ²	type (GWP)		R410A (2088)			
Qty. of refrigerant pre-charge ³ (tons of CO ₂ equivalent)	Kg		21.3 (44.47)	21.3 (44.47)	23.3 (48.65)	22.1 (46.14)
Compressor	nb. / type		4 / Scroll DC Inverter		5 / Scroll DC Inverter	
Piping diameter ⁴	Liquid	mm (inch)	19.05 (3/4")	19.05 (3/4")	19.05 (3/4")	19.05 (3/4")
	Gas	mm (inch)	38.1 (1-1/2")	38.1 (1-1/2")	41.3 (1-5/8")	41.3 (1-5/8")
Product Specifications						
Dimensions ⁵	WxHxD	mm	3810x1690x775	3810x1690x775	3810x1690x775	3810x1690x775
Net weight		Kg	870	875	895	925
Volume of air treated	max	m ³ /h	42400	42400	43000	43000
Available static pressure	std/max	Pa	0/110	0/110	0/110	0/110
Operating range (outdoor temperature)	Cooling	°C	-15~55	-15~55	-15~55	-15~55
	Heating	°C	-30~24	-30~24	-30~24	-30~24
Connectable air-to-air indoor units (max)	nb.		64	64	66	69
Capacity of connectable air-to-air indoor units	%		50 ~ 135			
Accessories						
Branch pipe kit for O.U. pairing	nb. / type		2 / DOS-68-MW-VA			

1. Value measured according to harmonized standard EN14511.

2. Refrigerant leakage contributes to climate change. Refrigerants with a lower global warming potential (GWP) contribute less to global warming when released into the atmosphere than those with a higher GWP. This appliance contains a refrigerant with a GWP of 2088. Therefore, if 1 kg of this refrigerant were released into the atmosphere, the impact on global warming would be 2088 times greater than 1 kg of CO₂, over a period of 100 years. Under no circumstances should the user attempt to intervene on the refrigerant circuit or disassemble the product. If necessary, always contact qualified personnel.

3. To calculate the additional refrigerant charge, refer to the labels located inside and outside the unit.

4. In combinations of multiple outdoor units, the diameters indicated refer to the section up to the first branch, with an equivalent length of less than 90 m.

5. Space between the combined units = 100 mm.

6. To determine the power of the connectable hydronic modules, consult the installation manual.

COMBINATIONS

M-VA-OV-900-SG	M-VA-OV-960-SG	M-VA-OV-1010-SG	M-VA-OV-1065-SG	M-VA-OV-1130-SG	M-VA-OV-1180-SG	M-VA-OV-1235-SG
32	34	36	38	40	42	44
280+615	335+615	400+615	450+615	500+615	560+615	615+615
89.50	95.00	101.50	106.50	111.90	117.50	123.00
23.74	25.47	27.00	29.34	30.23	32.94	34.94
3.77	3.73	3.76	3.63	3.70	3.57	3.52
100.50	106.50	114.00	119.00	125.50	132.00	138.00
25.00	26.28	28.77	30.59	31.52	33.16	35.20
4.02	4.05	3.96	3.89	3.98	3.98	3.92
3-380~415V-50Hz						
72.50	73.10	86.50	88.30	96.00	97.00	98.00
R410A (2088)						
13.8 (28.81)	15.8 (32.99)	15.8 (32.99)	15.8 (32.99)	16.6 (34.66)	16.6 (34.66)	16.6 (34.66)
3 / Scroll DC Inverter			4 / Scroll DC Inverter			
19.05 (3/4")	19.05 (3/4")	19.05 (3/4")	19.05 (3/4")	19.05 (3/4")	19.05 (3/4")	19.05 (3/4")
31.8 (1-1/4")	31.8 (1-1/4")	38.1 (1-1/2")	38.1 (1-1/2")	38.1 (1-1/2")	38.1 (1-1/2")	38.1 (1-1/2")
2370x1690x775	2370x1690x775	2780x1690x775	2780x1690x775	2780x1690x775	2780x1690x775	2780x1690x775
575	595	655	655	705	705	710
27000	27600	30000	31900	32500	33000	33000
0/110	0/110	0/110	0/110	0/110	0/110	0/110
-15~55	-15~55	-15~55	-15~55	-15~55	-15~55	-15~55
-30~24	-30~24	-30~24	-30~24	-30~24	-30~24	-30~24
53	56	59	63	64	64	64
50 ~ 135						
1 / DOS-68-MW-VA						

M-VA-OV-1515-SG	M-VA-OV-1580-SG	M-VA-OV-1630-SG	M-VA-OV-1685-SG	M-VA-OV-1750-SG	M-VA-OV-1800-SG	M-VA-OV-1845-SG
54	56	58	60	62	64	66
280+615+615	335+615+615	400+615+615	450+615+615	500+615+615	560+615+615	615+615+615
151.00	156.50	163.00	168.00	173.40	179.00	184.50
41.21	42.94	44.47	46.82	47.70	50.41	52.41
3.66	3.64	3.67	3.59	3.64	3.55	3.52
169.50	175.50	183.00	188.00	194.50	201.00	207.00
42.60	43.88	46.37	48.19	49.12	50.76	52.81
3.98	4.00	3.95	3.90	3.96	3.96	3.92
3-380~415-50						
121.50	122.10	135.50	137.30	145.00	146.00	147.00
R410A (2088)						
22.1 (46.14)	24.1 (50.32)	24.1 (50.32)	24.1 (50.32)	24.9 (51.99)	24.9 (51.99)	24.9 (51.99)
5 / Scroll DC Inverter			6 / Scroll DC Inverter			
19.05 (3/4")	19.05 (3/4")	19.05 (3/4")	19.05 (3/4")	19.05 (3/4")	19.05 (3/4")	19.05 (3/4")
41.3 (1-5/8")	41.3 (1-5/8")	41.3 (1-5/8")	41.3 (1-5/8")	41.3 (1-5/8")	41.3 (1-5/8")	41.3 (1-5/8")
3810x1690x775	3810x1690x775	4220x1690x775	4220x1690x775	4220x1690x775	4220x1690x775	4220x1690x775
930	950	1010	1010	1060	1060	1065
43500	44100	46500	48400	49000	49500	49500
0/110	0/110	0/110	0/110	0/110	0/110	0/110
-15~55	-15~55	-15~55	-15~55	-15~55	-15~55	-15~55
-30~24	-30~24	-30~24	-30~24	-30~24	-30~24	-30~24
71	74	77	80	80	80	80
50 ~ 135						
2 / DOS-68-MW-VA						

1. Value measured according to harmonized standard EN14511.

2. Refrigerant leakage contributes to climate change. Refrigerants with a lower global warming potential (GWP) contribute less to global warming when released into the atmosphere than those with a higher GWP. This appliance contains a refrigerant with a GWP of 2088. Therefore, if 1 kg of this refrigerant were released into the atmosphere, the impact on global warming would be 2088 times greater than 1 kg of CO₂, over a period of 100 years. Under no circumstances should the user attempt to intervene on the refrigerant circuit or disassemble the product. If necessary, always contact qualified personnel.

3. To calculate the additional refrigerant charge, refer to the labels located inside and outside the unit.

4. In combinations of multiple outdoor units, the diameters indicated refer to the section up to the first branch, with an equivalent length of less than 90 m.

5. Space between the combined units = 100 mm.

6. To determine the power of the connectable hydronic modules, consult the installation manual.

COMBINATIONS

Model			M-VA-OV-1908-SG	M-VA-OV-1962-SG	M-VA-OV-2016-SG	M-VA-OV-2072-SG
Power	HP		68	70	72	74
Combination			280+450+560+615	280+500+560+615	280+560+560+615	280+560+615+615
Rated capacity	Cooling	kW	190.50	195.90	201.50	207.00
Nominal absorbed power		kW	51.08	51.96	54.67	56.68
Energy efficiency coefficient (nominal)		EER ¹	3.73	3.77	3.69	3.65
Rated capacity	Heating	kW	213.50	220.00	226.50	232.50
Nominal absorbed power		kW	53.54	54.47	56.11	58.15
Energy performance coefficient (nominal)		COP ¹	3.99	4.04	4.04	4.00
Electrical Data						
Power supply	Ph-V-Hz		3-380~415-50			
Maximum current	A		159.80	167.50	168.50	169.50
Refrigerant Circuit Data						
Refrigerant ²	type (GWP)		R410A (2088)			
Q.ty of refrigerant pre-charge ³ (tons of CO ₂ equivalent)	Kg		29.6 (61.8)	30.4 (63.47)	30.4 (63.47)	30.4 (63.47)
Compressor	nb. / type		6 / Scroll DC Inverter		7 / Scroll DC Inverter	
Piping diameter ⁴	Liquid	mm (inch)	22.2 (7/8")	22.2 (7/8")	22.2 (7/8")	22.2 (7/8")
	Gas	mm (inch)	44.5 (1-3/4")	44.5 (1-3/4")	44.5 (1-3/4")	44.5 (1-3/4")
Product Specifications						
Dimensions ⁵	WxHxD	mm	5250x1690x775	5250x1690x775	5250x1690x775	5250x1690x775
Net weight		Kg	1225	1275	1275	1280
Volume of air treated	max	m ³ /h	58900	59500	60000	60000
Available static pressure	std/max	Pa	0/110	0/110	0/110	0/110
Operating range (outdoor temperature)	Cooling	°C	-15~55	-15~55	-15~55	-15~55
	Heating	°C	-30~24	-30~24	-30~24	-30~24
Connectable air-to-air indoor units (max)	nb.		80	80	80	80
Capacity of connectable air-to-air indoor units	%		50 ~ 135			
Accessories						
Branch pipe kit for O.U. pairing	nb. / type		3 / DOS-68-MW-VA			

1. Value measured according to harmonized standard EN14511.

2. Refrigerant leakage contributes to climate change. Refrigerants with a lower global warming potential (GWP) contribute less to global warming when released into the atmosphere than those with a higher GWP. This appliance contains a refrigerant with a GWP of 2088. Therefore, if 1 kg of this refrigerant were released into the atmosphere, the impact on global warming would be 2088 times greater than 1 kg of CO₂, over a period of 100 years. Under no circumstances should the user attempt to intervene on the refrigerant circuit or disassemble the product. If necessary, always contact qualified personnel.

3. To calculate the additional refrigerant charge, refer to the labels located inside and outside the unit.

4. In combinations of multiple outdoor units, the diameters indicated refer to the section up to the first branch, with an equivalent length of less than 90 m.

5. Space between the combined units = 100 mm.

6. To determine the power of the connectable hydronic modules, consult the installation manual.

COMBINATIONS

M-VA-OV-2128-SG	M-VA-OV-2184-SG	M-VA-OV-2240-SG	M-VA-OV-2295-SG	M-VA-OV-2350-SG	M-VA-OV-2405-SG	M-VA-OV-2460-SG
76	78	80	82	84	86	88
280+615+615+615	335+615+615+615	400+615+615+615	450+615+615+615	500+615+615+615	560+615+615+615	615+615+615+615
212.50	218.00	224.50	229.50	234.90	240.50	246.00
58.68	60.41	61.94	64.29	65.17	67.88	69.89
3.62	3.61	3.62	3.57	3.60	3.54	3.52
238.50	244.50	252.00	257.00	263.50	270.00	276.00
60.20	61.49	63.97	65.79	66.72	68.36	70.41
3.96	3.98	3.94	3.91	3.95	3.95	3.92
3-380~415-50						
170.50	171.10	184.50	186.30	194.00	195.00	196.00
R410A (2088)						
30.4 (63.47)	32.4 (67.65)	32.4 (67.65)	32.4 (67.65)	33.2 (69.32)	33.2 (69.32)	33.2 (69.32)
7 / Scroll DC Inverter			8 / Scroll DC Inverter			
22.2 (7/8")	22.2 (7/8")	22.2 (7/8")	22.2 (7/8")	22.2 (7/8")	22.2 (7/8")	22.2 (7/8")
44.5 (1-3/4")	44.5 (1-3/4")	44.5 (1-3/4")	44.5 (1-3/4")	44.5 (1-3/4")	44.5 (1-3/4")	44.5 (1-3/4")
5250x1690x775	5250x1690x775	5660x1690x775	5660x1690x775	5660x1690x775	5660x1690x775	5660x1690x775
1285	1305	1365	1365	1415	1415	1420
60000	60600	63000	64900	65500	66000	66000
0/110	0/110	0/110	0/110	0/110	0/110	0/110
-15~55	-15~55	-15~55	-15~55	-15~55	-15~55	-15~55
-30~24	-30~24	-30~24	-30~24	-30~24	-30~24	-30~24
80	80	80	80	80	80	80
50 ~ 135						
3 / D05-68-MW-VA						

1. Value measured according to harmonized standard EN14511.

2. Refrigerant leakage contributes to climate change. Refrigerants with a lower global warming potential (GWP) contribute less to global warming when released into the atmosphere than those with a higher GWP. This appliance contains a refrigerant with a GWP of 2088. Therefore, if 1 kg of this refrigerant were released into the atmosphere, the impact on global warming would be 2088 times greater than 1 kg of CO₂, over a period of 100 years. Under no circumstances should the user attempt to intervene on the refrigerant circuit or disassemble the product. If necessary, always contact qualified personnel.

3. To calculate the additional refrigerant charge, refer to the labels located inside and outside the unit.

4. In combinations of multiple outdoor units, the diameters indicated refer to the section up to the first branch, with an equivalent length of less than 90 m.

5. Space between the combined units = 100 mm.

6. To determine the power of the connectable hydronic modules, consult the installation manual.



THE MW 3-PIPE SYSTEM HEAT RECOVERY IN INDIVIDUAL OR MODULAR USE

OUTDOOR UNITS

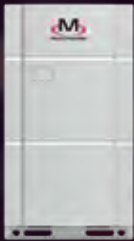

22.40 kW	28.00 kW	33.50 kW
8HP	10HP	12HP
M-VR-OV-224-SG	M-VR-OV-280-SG	M-VR-OV-335-SG



40.00 kW	45.00 kW	50.40 kW	56.00 kW	61.50 kW
14HP	16HP	18HP	20HP	22HP
M-VR-OV-400-SG	M-VR-OV-450-SG	M-VR-OV-500-SG	M-VR-OV-560-SG	M-VR-OV-615-SG

FLOW CONTROLLERS

Nb. of connections	Nb. of connections	Nb. of connections	Nb. of connections
1	2	4	8
M-VR-ME-1-NG	M-VR-ME-2-NG	M-VR-ME-4-NG	M-VR-ME-8-NG



HYDRONIC MODULE



16.00 kW
1-Phase
M-VR-HM-16-NG
30.00 kW
1-Phase
M-VR-HM-30-NG

INDOOR UNITS

Applicable indoor units for air-to-air operation on page. 93



MW 3-PIPE HEAT RECOVERY CONSISTS OF 8 INDIVIDUAL OUTDOOR UNITS. IN COMBINATION IT REACHES A MAXIMUM OUTPUT OF 246 KW TO WHICH UP TO 80 INDOOR UNITS CAN BE CONNECTED

8 THREE-PHASE MODELS

The maximum power of the single outdoor unit reaches 61.5 kW (22 HP); the maximum power of the combined outdoor units reaches 246 kW (88 HP), the highest value in the industry.

The MW 3-PIPE system is able to create combinations of 4 external units, to which up to 80 internal units can be connected, thanks to the most advanced CAN+ technology.

POWER AND NUMBER OF CONNECTABLE INDOOR UNITS

Model	Min~Max power of connectable I.U.	Min~Max number of connectable I.U.	Max power of connectable hydronic modules [kW]	Max number of connectable hydronic modules
M-VR-OV-224-SG	50~135%	1~13	32	2
M-VR-OV-280-SG	50~135%	1~16	32	2
M-VR-OV-335-SG	50~135%	1~19	32	2
M-VR-OV-400-SG	50~135%	1~23	32	2
M-VR-OV-450-SG	50~135%	1~26	46	2
M-VR-OV-500-SG	50~135%	1~29	46	2
M-VR-OV-560-SG	50~135%	1~33	46	2
M-VR-OV-615-SG	50~135%	1~36	60	2

MAXIMUM COMPACTNESS FOR ALL OUTDOOR UNITS

Compactness is another important plus. There are two aesthetics proposed, with a single fan (from 22.4 to 33.5 kW) and with a double fan (from 40 to 61.5 kW).

22.40 - 28.00 - 33.50 kW



L 930 x H 1690 x D 775 (mm)

40.00 - 45.00 - 50.40 - 56.00 - 61.50 kW



L 1340 x H 1690 x D 775 (mm)

MIX OF TECHNOLOGIES TO ENSURE MAXIMUM EFFICIENCY AND ENERGY SAVINGS

The MULTIWARM 3-PIPE system with heat recovery can simultaneously meet the needs of air conditioning, heating and hot water production.

The MULTIWARM 3-PIPE range is particularly suitable for many types of applications: villas, shops, offices, shopping centres, hotels, hospitals, banks, museums, schools.

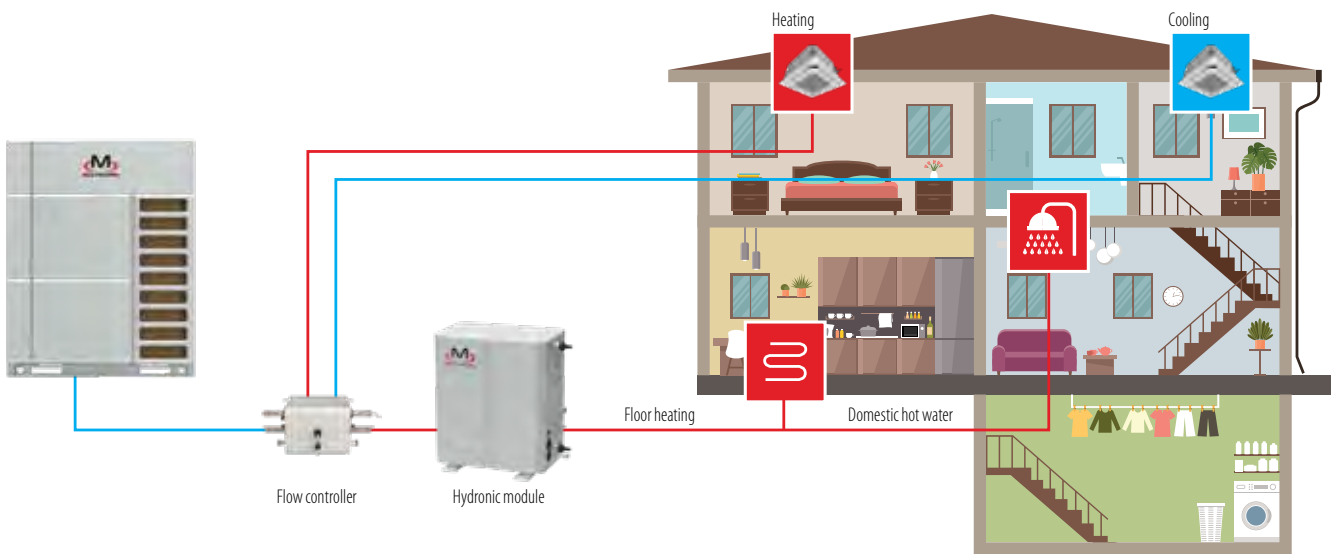

All DC Inverter Compressors

The use of All DC Inverter compressors guarantees excellent system efficiency both at full load and partial load. The high efficiency permanent magnet synchronous motor produces a better performance than the traditional DC Inverter compressor.

The system can directly absorb gas to reduce superheat loss.



+ medium and high frequency performance, thanks to the new structure of the high pressure chamber

+ low frequency efficiency, with the new concentrated winding motor

DC Inverter Sensorless Fan Motor



Linear speed regulation ranges from 5 to 65 Hz. Compared with traditional Inverter motors, operation is more efficient.

Sensorless control technology ensures quieter operation, less vibration and smoother operation.

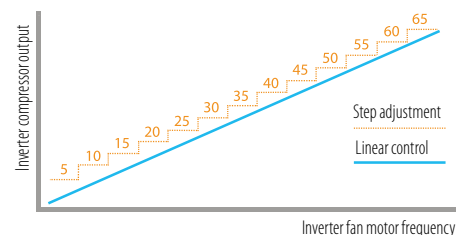

Enhanced Vapour Injection "EVI" technology

This special technology applied to the compressor uses part of the refrigerant to maximize performance while improving energy efficiency.

Automatic load control

The unit intelligently detects and controls system parameters, adapting them to actual cooling/heating needs.

Automatically adjusts the refrigerant heat exchange temperature according to the increase or decrease in ambient temperature.

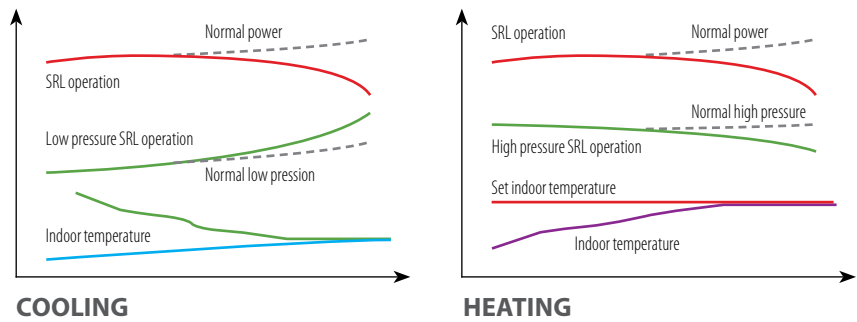

Control technology with energy savings of up to 20%

The MW 3-PIPE system has two energy saving modes:

- > **Automatic energy saving:** automatically adjusts the parameters according to the working status, thus reducing the cost of electricity. It can save up to 15% energy.
- > **Forced energy saving:** forcibly limits the output power. Depending on the power consumption and user needs, a capacity ratio of 90% or 80% can be selected.

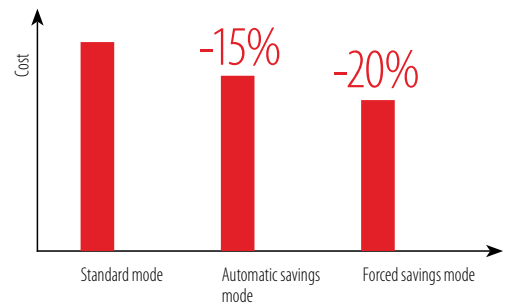

Up to 80 connectable indoor units

The Multiwarm 3-PIPE system can be installed in combinations of up to 4 outdoor units, and is capable of connecting up to 80 indoor units.

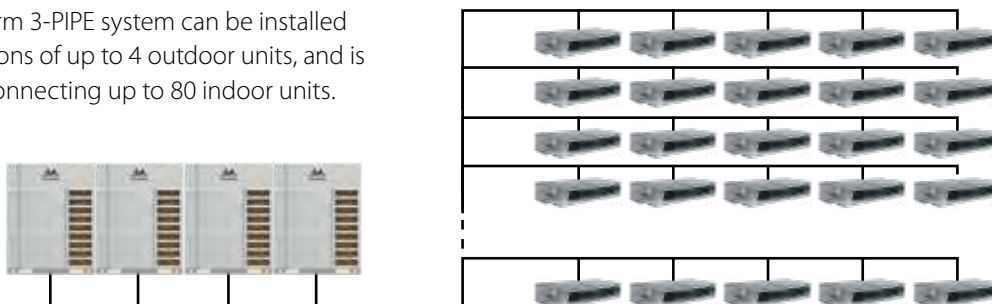

SILENT COMFORT THAT LASTS OVER TIME

Wide operating range, from -25°C to 55°C , fast start-up times, rapid defrosting without performance drops. Reduced noise for maximum comfort in all environments.

Wide range of operation and operating conditions

Operation is possible for voltages from 380 to 415V, at 50Hz.

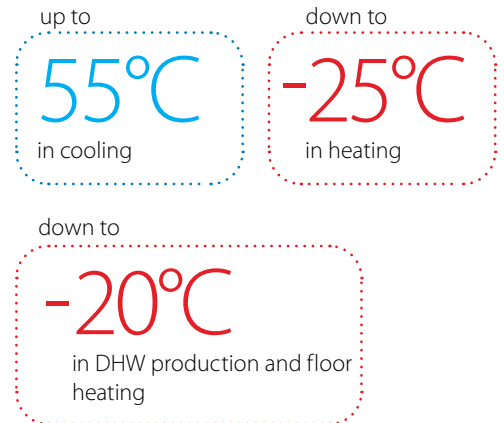
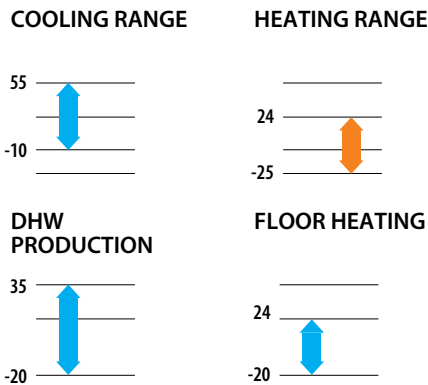

Heat storage defrosting technology (optional module)

The heat storage module is optional and offers the advantage of an innovative and intelligent defrosting mode, allowing you to accelerate heat transfer, defrost quickly and maintain constant comfort.

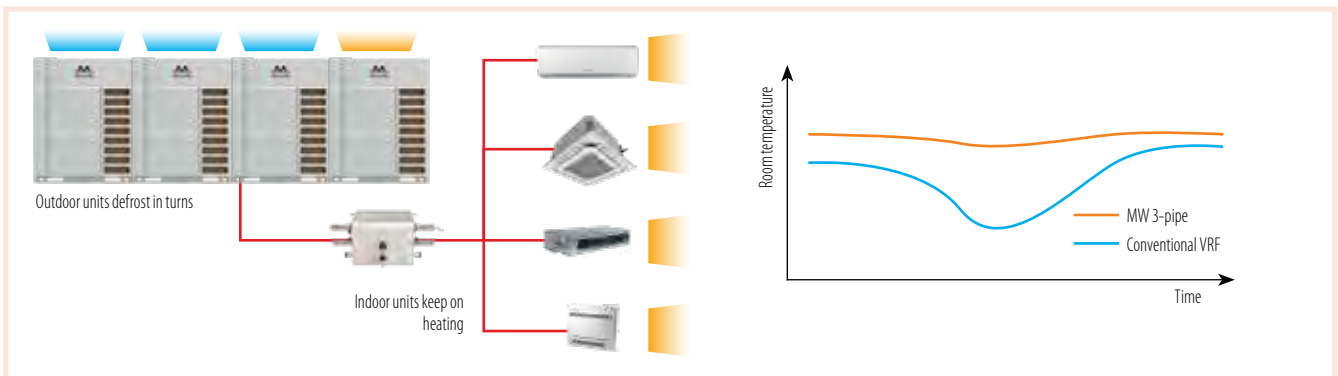

Reduction of pre-heating time

The motor's electric winding and the heating belt are activated simultaneously, heating the oil and ensuring rapid and complete evaporation of the coolant. This allows the pre-heating time to be reduced by 75%, from 8 to 2 hours.



Intelligent defrosting and auto-adaptive control

It occurs with variable cycles and capacities based on the system temperature, pressure and speed of the workload. The MW 3-PIPE system can automatically change the compressor capacity during defrosting by evaluating the parameters in real time, so as to obtain stable or fast defrosting.

Outdoor unit silent mode and sound level control

The system can learn, define and remember user habits. It can automatically determine the system capacity in the next 24 hours to achieve automatic silent operation.

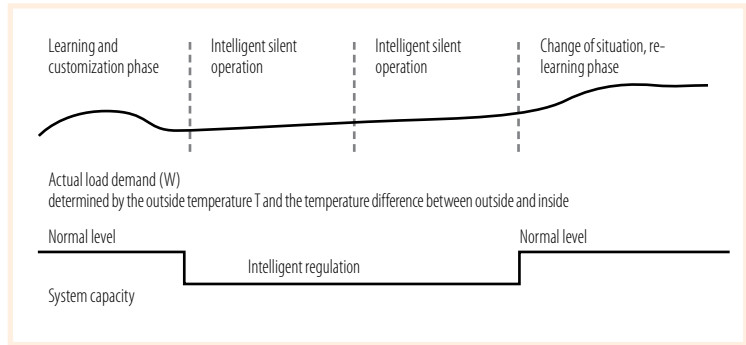

Optimized fan housing design

The fan housing structure reduces vibrations during operation. This allows a reduction in noise level of up to 3 dB(A).



3D aerodynamic axial fan

Its special inverted S-shape, while ensuring a significant increase in air flow, has the advantage of containing noise emissions.

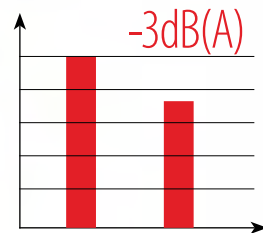

Sound absorption and insulation

The use of high-quality sound-absorbing materials ensures optimum insulation of the compressor and other components. The use of sound-absorbing cotton + insulation box allows the unit's noise level to be controlled.



Sound-absorbing cotton



Insulation box

Intelligent control of the refrigeration circuit

The system intelligently judges whether the refrigerant circulation amount is sufficient based on the system parameters (pressure, temperature, speed, etc.). The refrigerant transfer is performed automatically.

EXCELLENT PERFORMANCE

The new generation intelligent management control system and healthy fresh air solution ensure excellent energy saving, comfort and reliability.

Highly efficient heat exchanger

The heat exchanger has a design such that the battery has been divided into two distinct areas (upper and lower) to improve the flow of the refrigerant: the flow scheme adopted (1-2-2-1), compared to the traditional one, guarantees a better heat exchange.

Its characteristics:

- > corrugated heat exchange fins with reduced pitch;
- > reduced fin section, increased corrosion resistance;
- > wavy hydrophilic design, easier defrosting.

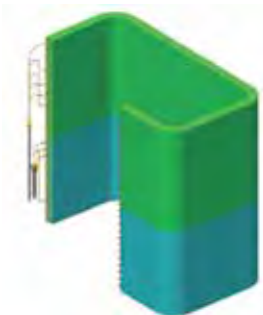
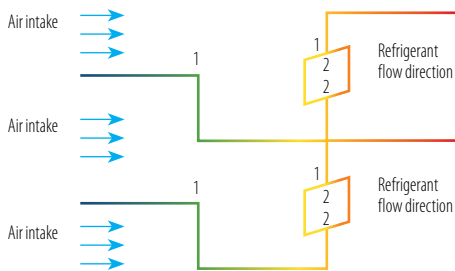

Wide airflow

The inverted S-shaped fan blade design allows for a larger action area and consequently a greater volume of air treated at the same rpm.

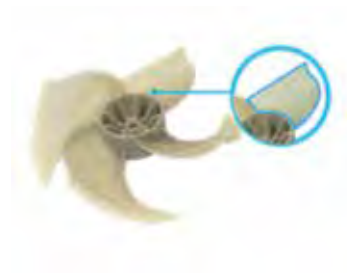

HPAC function - intelligent switching control

The MW 3-PIPE system adopts a brand new modular control method that ensures not only the operating life of the entire unit, but also the overall operating energy efficiency through intelligent switching, modulated according to the load demands of the indoor unit.



VRF traditional system

MW 3-pipe

RELIABILITY OVER TIME AND EASY MAINTENANCE

Heat exchanger with Golden Fin treatment against corrosion. Protects against atmospheric phenomena and the effects of aggressive environments.

Alternating control of variable cycle modules

The HPAC function, with intelligent switching between outdoor units according to a variable control cycle based on the load demands of the indoor unit, helps to increase the reliability of the system over time.

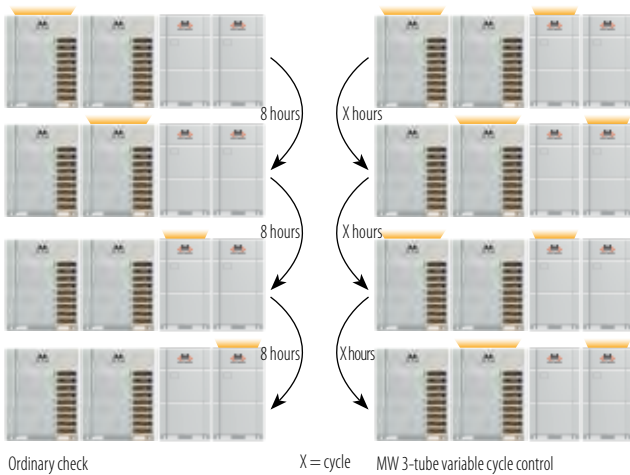

Compressor rotation control

The overall life of the modular units is considered in the system control. When there is more than one compressor, the internal compressors will operate in turn to balance the life of each compressor.



Golden Fin Anti-Corrosion Protection

The main material of the Golden Fin is a rust-proof aluminum-manganese (Al-Mn) alloy, coated with the Golden Protection Layer (anti-corrosion layer composed of epoxy resin and modified acrylic, without silicone) whose anti-corrosion performance in the salt spray test is 200-300% higher than that of normal Blue Fins.

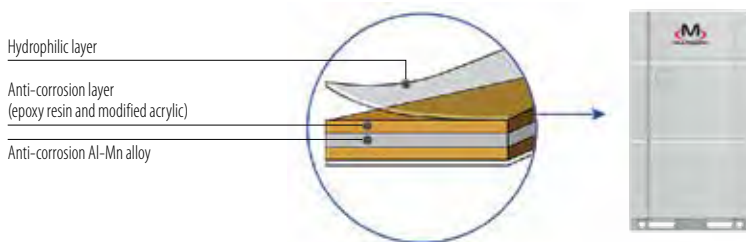

FLEXIBILITY AND SIMPLICITY OF INSTALLATION

The maximum overall pipe length available on the market, equal to 1,000 m, allows installation in a wide range of buildings, with maximum flexibility.

High split length

- Maximum effective length of a single pipe = 200 m
- Maximum equivalent length of a single pipe = 240 m
- Maximum length of pipes = 1000 m
- Maximum length after first branch = 120 m
- Maximum height difference of indoor and outdoor units = 110 m
- Maximum height difference between indoor units = 30 m

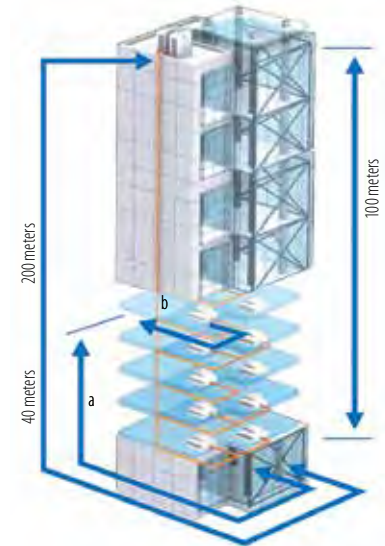

Smart Start

QUICK INSTALLATION

- > Automatic address assignment to indoor units, no DIP switch required for start-up.
- > Five-sided outlet pipe connection method: maximum installation versatility.
- > No external oil balance tube thanks to advanced oil balance control.
- > Highly versatile design.

EFFICIENT MULTIPLE STARTS



Quick start with just one button.



Clear interface, detailed data and professional analysis.



Multifunctional debugger, quick connection, no special PC needed, automatic data storage, no external memory. Debugging without installation wired control.

Air ducting - maximum versatility

The design of the outdoor unit fan allows for a very high static pressure of the outdoor unit, with a range from 0 to 110 Pa. This makes the installation of the machine more versatile and suitable for different types of environments, especially in cases where it is necessary to position the outdoor units inside the rooms.



Large spaces for easy maintenance

The MW 3-PIPE system is designed with integrated electric control and reserved maintenance space, to facilitate after-sales service.



Excellent emergency operation

EMERGENCY FUNCTION

The system can realize a combination of 4 modules with outdoor units. When an error occurs in one of the modules, the other modules take over the emergency operation to continue the service.



EMERGENCY OPERATION OF THE FAN

Thanks to the dual fan design, one of the two fans can continue to operate if the other one fails.



COMPRESSOR EMERGENCY OPERATION

All compressors in each module are DC Inverter and when one compressor fails, the others take over the emergency operation.

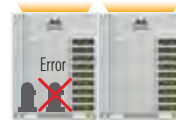

EMERGENCY OPERATION OF THE SENSOR

If there is a sensor problem on one indoor unit, it can be turned off while the other units continue to operate. A maximum of 3 indoor units can be turned off at the same time.



Automatic refrigerant recovery

The advanced automatic refrigerant recovery function from the indoor and outdoor units allows the refrigerant to be effectively recovered from the units in the event of a malfunction, avoiding gas dispersion and reducing intervention times.

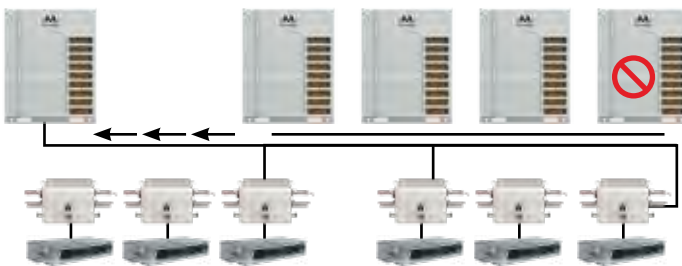

Emergency function of the indoor unit

When an indoor unit needs to be turned off for maintenance, the other indoor units connected to the same system remain in operation.

Auto-positioning function of indoor units

If multiple indoor units are installed in large spaces such as exhibition halls, conference rooms and offices, the auto-positioning function enables the indoor unit buzzers to sound so you can quickly locate them.





OUTDOOR UNITS

3 REFRIGERANT CAPACITIES
22.40 - 28.00 - 33.50 kW

R410A
Refrigerant gas

DC Inverter compressors guarantee total reliability thanks to high energy efficiency and silence. In addition, they allow a reduction in vibrations and accurate control of the operating frequency.



OPERATION RANGE

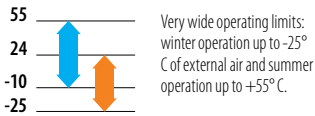

M-VR-OV-224-SG
M-VR-OV-280-SG
M-VR-OV-335-SG

Model			M-VR-OV-224-SG	M-VR-OV-280-SG	M-VR-OV-335-SG
Power		HP	8	10	12
Nominal Data					
Rated capacity	Cooling	kW	22.40	28.00	33.50
Nominal absorbed power		kW	4.98	6.48	8.19
Energy efficiency coefficient (nominal)		EER ¹	4.50	4.32	4.09
Rated capacity	Heating	kW	25.00	31.50	37.50
Nominal absorbed power		kW	5.10	7.24	8.91
Energy performance coefficient (nominal)		COP ¹	4.90	4.35	4.21
Seasonal Data					
Seasonal energy efficiency index	Cooling	SEER ²	7.00	6.70	6.55
Seasonal performance coefficient	Heating	SCOP ²	4.32	4.58	4.74
Seasonal energy efficiency (ns)		%	169.80	180.20	186.60
Electrical Data					
Power supply		Ph-V-Hz	3-380~415V-50Hz		
Maximum current		A	23.00	23.50	24.10
Refrigerant Circuit Data					
Refrigerant ³		type (GWP)	R410A (2088)		
Q.ty of refrigerant pre-charge ⁴ (tons of CO2 equivalent)		Kg	8.2 (17.12)	8.5 (17.75)	9.6 (20.04)
Compressor		nb. / type	1 / Scroll DC Inverter		
Piping diameter	Liquid	mm (inch)	9.52 (3/8")	9.52 (3/8")	12.7 (1/2")
	Gas HP	mm (inch)	15.9 (5/8")	19.05 (3/4")	19.05 (3/4")
	Gas LP	mm (inch)	19.05 (3/4")	22.2 (7/8")	25.4 (1")
Product Specifications					
Dimensions	WxHxD	mm	930x1690x775	930x1690x775	930x1690x775
Net weight		Kg	243	243	256
Sound power level	max	dB(A)	80	82	84
Sound pressure level at 1 m	max	dB(A)	60	61	63
Volume of air treated	max	m ³ /h	9750	10500	11100
Available static pressure	std/max	Pa	0/110	0/110	0/110
	Cooling	°C	-10~-55	-10~-55	-10~-55
Operating range (outdoor temperature)	Heating	°C	-25~-24	-25~-24	-25~-24
	Hydronic heating	°C	-20~-24	-20~-24	-20~-24
	Domestic hot water (DHW)	°C	-20~-35	-20~-35	-20~-35
Connectable air-to-air indoor units (max)		nb.	13	16	19
Connectable air-to-water hydronic modules (max) ⁵		nb.	2	2	2
Capacity of connectable air-to-air indoor units		%	50 ~ 135		

1. Value measured according to the harmonized standard EN14511.

2. EU Regulation No. 206/2012 -- Value measured according to the harmonized standard EN14825.

3. Refrigerant leakage contributes to climate change. If released into the atmosphere, refrigerants with a lower global warming potential (GWP) contribute less to global warming than those with a higher GWP. This appliance contains a refrigerant with a GWP of 2088. If 1 kg of this refrigerant were released into the atmosphere, therefore, the impact on global warming would be 2088 times higher than 1 kg of CO₂, over a period of 100 years. Under no circumstances should the user attempt to intervene on the refrigerant circuit or disassemble the product. If necessary, always contact qualified personnel.

4. To calculate the additional refrigerant charge, refer to the labels located inside and outside the unit.

5. To determine the power of the connectable hydronic modules, consult the installation manual.

OUTDOOR UNITS

5 REFRIGERANT CAPACITIES
40.00 - 45.00 - 50.40 - 56.00 - 61.50 kW

R410A
Refrigerant gas

DC Inverter compressors guarantee total reliability thanks to high energy efficiency and silence. In addition, they allow a reduction in vibrations and accurate control of the operating frequency.



OPERATION RANGE



- M-VR-OV-400-SG
- M-VR-OV-450-SG
- M-VR-OV-500-SG
- M-VR-OV-560-SG
- M-VR-OV-615-SG

Model			M-VR-OV-400-SG	M-VR-OV-450-SG	M-VR-OV-500-SG	M-VR-OV-560-SG	M-VR-OV-615-SG
Power	HP		14	16	18	20	22
Nominal Data							
Rated capacity	Cooling	kW	40.00	45.00	50.40	56.00	61.50
Nominal absorbed power		kW	9.76	11.45	12.99	15.82	18.52
Energy efficiency coefficient (nominal)		EER ¹	4.10	3.93	3.88	3.54	3.32
Rated capacity	Heating	kW	45.00	50.00	56.50	63.00	69.00
Nominal absorbed power		kW	10.84	12.47	14.49	16.71	18.40
Energy performance coefficient (nominal)		COP ¹	4.15	4.01	3.90	3.77	3.75
Seasonal Data							
Seasonal energy efficiency index	Cooling	SEER ²	6.91	6.46	6.48	6.32	6.32
Seasonal performance coefficient	Heating	SCOP ²	4.44	4.42	4.25	4.15	4.15
Seasonal energy efficiency (η _s)		%	174.60	173.80	167.00	163.00	163.00
Electrical Data							
Power supply	Ph-V-Hz		3-380~415V-50Hz				
Maximum current	A		37.50	39.30	47.00	48.00	49.00
Refrigerant Circuit Data							
Refrigerant ³	type (GWP)		R410A (2088)				
Q.ty of refrigerant pre-charge ⁴ (tons of CO ₂ equivalent)	Kg		11.1 (23.18)	11.6 (24.22)	12.8 (26.73)	12.8 (26.73)	13.3 (27.77)
Compressor	nb. / type		1 / Scroll DC Inverter		2 / Scroll DC Inverter		
Piping diameter	Liquid	mm (inch)	12.7 (1/2")	12.7 (1/2")	15.9 (5/8")	15.9 (5/8")	15.9 (5/8")
	Gas HP	mm (inch)	22.2 (7/8")	22.2 (7/8")	25.4 (1")	25.4 (1")	25.4 (1")
	Gas LP	mm (inch)	25.4 (1")	28.6 (1-1/8")	28.6 (1-1/8")	28.6 (1-1/8")	28.6 (1-1/8")
Product Specifications							
Dimensions	WxHxD	mm	1340x1690x775	1340x1690x775	1340x1690x775	1340x1690x775	1340x1690x775
Net weight		Kg	325	325	385	385	385
Sound power level	max	dB(A)	91	91	88	88	88
Sound pressure level at 1 m	max	dB(A)	63	63	63	63	64
Volume of air treated	max	m ³ /h	13500	15400	16500	16500	16500
Available static pressure	std/max	Pa	0/110	0/110	0/110	0/110	0/110
	Cooling	°C	-10~-55	-10~-55	-10~-55	-10~-55	-10~-55
Operating range (outdoor temperature)	Heating	°C	-25~-24	-25~-24	-25~-24	-25~-24	-25~-24
	Hydronic heating	°C	-20~-24	-20~-24	-20~-24	-20~-24	-20~-24
	Domestic hot water (DHW)	°C	-20~-35	-20~-35	-20~-35	-20~-35	-20~-35
Connectable air-to-air indoor units (max)	nb.		23	26	29	33	36
Connectable air-to-water hydronic modules (max) ⁵	nb.		2	2	2	2	2
Capacity of connectable air-to-air indoor units	%		50 ~ 135				

1. Value measured according to the harmonized standard EN14511.

2. EU Regulation No. 206/2012 -- Value measured according to the harmonized standard EN14825.

3. Refrigerant leakage contributes to climate change. If released into the atmosphere, refrigerants with a lower global warming potential (GWP) contribute less to global warming than those with a higher GWP. This appliance contains a refrigerant with a GWP of 2088. If 1 kg of this refrigerant were released into the atmosphere, therefore, the impact on global warming would be 2088 times higher than 1 kg of CO₂, over a period of 100 years. Under no circumstances should the user attempt to intervene on the refrigerant circuit or disassemble the product. If necessary, always contact qualified personnel.

4. To calculate the additional refrigerant charge, refer to the labels located inside and outside the unit.

5. To determine the power of the connectable hydronic modules, consult the installation manual.

COMBINATIONS

Model		M-VR-OV-680-SG	M-VR-OV-730-SG	M-VR-OV-785-SG	M-VR-OV-850-SG
Power	HP	24	26	28	30
Combination		280+400	280+450	280+500	280+560
Rated capacity	Cooling	kW	68.00	73.00	78.40
Nominal absorbed power		kW	16.24	17.93	19.47
Energy efficiency coefficient (nominal)		EER1	4.19	4.07	4.03
Rated capacity	Heating	kW	76.50	81.50	88.00
Nominal absorbed power		kW	18.08	19.71	21.73
Energy performance coefficient (nominal)		COP1	4.23	4.13	4.05
Electrical Data					
Power supply	Ph-V-Hz	3-380~415V-50Hz			
Maximum current	A	61.00	62.80	70.50	71.50
Refrigerant Circuit Data					
Refrigerant2	type (GWP)	R410A (2088)			
Q.ty of refrigerant pre-charge 3 (tons of CO2 equivalent)	Kg	19.6 (40.93)	20.1 (41.97)	21.3 (44.48)	21.3 (44.48)
Compressor	nb. / type	2 / Scroll DC Inverter		3 / Scroll DC Inverter	
Piping diameter4	Liquid	mm (inch)	15.9 (5/8")	19.05 (3/4")	19.05 (3/4")
	Gas HP	mm (inch)	25.4 (1")	28.6 (1-1/8")	28.6 (1-1/8")
	Gas LP	mm (inch)	28.6 (1-1/8")	31.8 (1-1/4")	31.8 (1-1/4")
Product Specifications					
Dimensions5	WxHxD	mm	2370x1690x775	2370x1690x775	2370x1690x775
Net weight		Kg	568	568	628
Volume of air treated	max	m3/h	24000	25900	27000
Available static pressure	std/max	Pa	0/110	0/110	0/110
	Cooling	°C	-10~-55	-10~-55	-10~-55
Operating range (outdoor temperature)	Heating	°C	-25~-24	-25~-24	-25~-24
	Hydronic heating	°C	-20~-24	-20~-24	-20~-24
	Domestic hot water (DHW)	°C	-20~-35	-20~-35	-20~-35
Connectable air-to-air indoor units (max)	nb.	39	43	46	50
Connectable air-to-water hydronic modules (max)6	nb.	4	4	4	4
Capacity of connectable air-to-air indoor units	%	50 ~ 135			
Accessories					
Branch pipe kit for O.U. pairing	nb. / type	1 / DOS-68-MW-VR			

Model		M-VR-OV-1300-SG	M-VR-OV-1350-SG	M-VR-OV-1410-SG	M-VR-OV-1460-SG
Power	HP	46	48	50	52
Combination		280+450+560	280+450+615	335+450+615	280+560+615
Rated capacity	Cooling	kW	129.00	134.50	145.50
Nominal absorbed power		kW	33.75	36.46	38.17
Energy efficiency coefficient (nominal)		EER1	3.82	3.69	3.67
Rated capacity	Heating	kW	144.50	150.50	156.50
Nominal absorbed power		kW	36.42	38.11	39.78
Energy performance coefficient (nominal)		COP1	3.97	3.95	3.93
Electrical Data					
Power supply	Ph-V-Hz	3-380~415-50			
Maximum current	A	110.80	111.80	112.40	120.50
Refrigerant Circuit Data					
Refrigerant2	type (GWP)	R410A (2088)			
Q.ty of refrigerant pre-charge 3 (tons of CO2 equivalent)	Kg	32.9 (68.70)	33.4 (69.74)	34.5 (72.03)	34.6 (72.25)
Compressor	nb. / type	4 / Scroll DC Inverter			5 / Scroll DC Inverter
Piping diameter4	Liquid	mm (inch)	19.05 (3/4")	19.05 (3/4")	19.05 (3/4")
	Gas HP	mm (inch)	31.8 (1-1/4")	31.8 (1-1/4")	38.1 (1-1/2")
	Gas LP	mm (inch)	38.1 (1-1/2")	38.1 (1-1/2")	41.3 (1-5/8")
Product Specifications					
Dimensions5	WxHxD	mm	3810x1690x775	3810x1690x775	3810x1690x775
Net weight		Kg	953	953	1013
Volume of air treated	max	m3/h	42400	42400	43000
Available static pressure	std/max	Pa	0/110	0/110	0/110
	Cooling	°C	-10~-55	-10~-55	-10~-55
Operating range (outdoor temperature)	Heating	°C	-25~-24	-25~-24	-25~-24
	Hydronic heating	°C	-20~-24	-20~-24	-20~-24
	Domestic hot water (DHW)	°C	-20~-35	-20~-35	-20~-35
Connectable air-to-air indoor units (max)	nb.	64	64	66	69
Connectable air-to-water hydronic modules (max)6	nb.	6	6	6	6
Capacity of connectable air-to-air indoor units	%	50 ~ 135			
Accessories					
Branch pipe kit for O.U. pairing	nb. / type	1 / DOS-68-MW-VR + 1 / DOS-246-MW-VR			

1. Value measured according to harmonized standard EN14511.

2. Refrigerant leakage contributes to climate change. Refrigerants with a lower global warming potential (GWP) contribute less to global warming when released into the atmosphere than those with a higher GWP. This appliance contains a refrigerant with a GWP of 2088. Therefore, if 1 kg of this refrigerant were released into the atmosphere, the impact on global warming would be 2088 times greater than 1 kg of CO2, over a period of 100 years. Under no circumstances should the user attempt to intervene on the refrigerant circuit or disassemble the product. If necessary, always contact qualified personnel.

3. To calculate the additional refrigerant charge, refer to the labels located inside and outside the unit.

4. In combinations of multiple outdoor units, the diameters indicated refer to the section up to the first branch, with an equivalent length of less than 90 m.

5. Space between the combined units = 100 mm.

6. To determine the power of the connectable hydronic modules, consult the installation manual.

COMBINATIONS

M-VR-OV-900-SG	M-VR-OV-960-SG	M-VR-OV-1010-SG	M-VR-OV-1065-SG	M-VR-OV-1130-SG	M-VR-OV-1180-SG	M-VR-OV-1235-SG
32	34	36	38	40	42	44
280+615	335+615	400+615	450+615	500+615	560+615	615+615
89.50	95.00	101.50	106.50	111.50	117.50	123.00
25.01	26.71	28.28	29.97	31.51	34.34	37.05
3.58	3.56	3.59	3.55	3.55	3.42	3.32
100.50	106.50	114.00	119.00	125.50	132.00	138.00
25.64	27.31	29.24	30.87	32.89	35.11	36.80
3.92	3.90	3.90	3.86	3.82	3.76	3.75
3-380~415V-50Hz						
72.50	73.10	86.50	88.30	96.00	97.00	98.00
R410A (2088)						
21.8 (45.52)	22.9 (47.81)	24.4 (50.95)	24.9 (51.99)	26.1 (54.50)	26.1 (54.50)	26.6 (55.54)
3 / Scroll DC Inverter			4 / Scroll DC Inverter			
19.05 (3/4")	19.05 (3/4")	19.05 (3/4")	19.05 (3/4")	19.05 (3/4")	19.05 (3/4")	19.05 (3/4")
28.6 (1-1/8")	28.6 (1-1/8")	28.6 (1-1/8")	31.8 (1-1/4")	31.8 (1-1/4")	31.8 (1-1/4")	31.8 (1-1/4")
31.8 (1-1/4")	31.8 (1-1/4")	31.8 (1-1/4")	38.1 (1-1/2")	38.1 (1-1/2")	38.1 (1-1/2")	38.1 (1-1/2")
2370x1690x775	2370x1690x775	2780x1690x775	2780x1690x775	2780x1690x775	2780x1690x775	2780x1690x775
628	641	710	710	770	770	770
27000	27600	30000	31900	33000	33000	33000
0/110	0/110	0/110	0/110	0/110	0/110	0/110
-10~55	-10~55	-10~55	-10~55	-10~55	-10~55	-10~55
-25~24	-25~24	-25~24	-25~24	-25~24	-25~24	-25~24
-20~24	-20~24	-20~24	-20~24	-20~24	-20~24	-20~24
-20~35	-20~35	-20~35	-20~35	-20~35	-20~35	-20~35
53	56	59	63	64	64	64
4	4	4	4	4	4	4
50 ~ 135						
1 / DOS-68-MW-VR			1 / DOS-246-MW-VR			

M-VR-OV-1515-SG	M-VR-OV-1580-SG	M-VR-OV-1630-SG	M-VR-OV-1685-SG	M-VR-OV-1750-SG	M-VR-OV-1800-SG	M-VR-OV-1845-SG
54	56	58	60	62	64	66
280+615+615	335+615+615	400+615+615	450+615+615	500+615+615	560+615+615	615+615+615
151.00	156.50	163.00	168.00	173.40	179.00	184.50
43.53	45.24	46.80	48.50	50.04	52.87	55.57
3.47	3.46	3.48	3.46	3.47	3.39	3.32
169.50	175.50	183.00	188.00	194.50	201.00	207.00
44.04	45.71	47.64	49.27	51.29	53.51	55.20
3.85	3.84	3.84	3.82	3.79	3.76	3.75
3-380~415-50						
121.50	122.10	135.50	137.30	145.00	146.00	147.00
R410A (2088)						
35.1 (73.29)	36.2 (75.58)	37.7 (78.72)	38.2 (79.76)	39.4 (82.27)	39.4 (82.27)	39.9 (83.31)
5 / Scroll DC Inverter			6 / Scroll DC Inverter			
19.05 (3/4")	19.05 (3/4")	19.05 (3/4")	19.05 (3/4")	19.05 (3/4")	19.05 (3/4")	19.05 (3/4")
38.1 (1-1/2")	38.1 (1-1/2")	38.1 (1-1/2")	38.1 (1-1/2")	38.1 (1-1/2")	38.1 (1-1/2")	38.1 (1-1/2")
41.3 (1-5/8")	41.3 (1-5/8")	41.3 (1-5/8")	41.3 (1-5/8")	41.3 (1-5/8")	41.3 (1-5/8")	41.3 (1-5/8")
3810x1690x775	3810x1690x775	4220x1690x775	4220x1690x775	4220x1690x775	4220x1690x775	4220x1690x775
1013	1026	1095	1095	1155	1155	1155
43500	44100	46500	48400	49500	49500	49500
0/110	0/110	0/110	0/110	0/110	0/110	0/110
-10~55	-10~55	-10~55	-10~55	-10~55	-10~55	-10~55
-25~24	-25~24	-25~24	-25~24	-25~24	-25~24	-25~24
-20~24	-20~24	-20~24	-20~24	-20~24	-20~24	-20~24
-20~35	-20~35	-20~35	-20~35	-20~35	-20~35	-20~35
71	74	77	80	80	80	80
6	6	6	6	6	6	6
50 ~ 135						
1 / DOS-68-MW-VR + 1 / DOS-246-MW-VR			2 / DOS-246-MW-VR			

1. Value measured according to harmonized standard EN14511.

2. Refrigerant leakage contributes to climate change. Refrigerants with a lower global warming potential (GWP) contribute less to global warming when released into the atmosphere than those with a higher GWP. This appliance contains a refrigerant with a GWP of 2088. Therefore, if 1 kg of this refrigerant were released into the atmosphere, the impact on global warming would be 2088 times greater than 1 kg of CO₂, over a period of 100 years. Under no circumstances should the user attempt to intervene on the refrigerant circuit or disassemble the product. If necessary, always contact qualified personnel.

3. To calculate the additional refrigerant charge, refer to the labels located inside and outside the unit.

4. In combinations of multiple outdoor units, the diameters indicated refer to the section up to the first branch, with an equivalent length of less than 90 m.

5. Space between the combined units = 100 mm.

6. To determine the power of the connectable hydronic modules, consult the installation manual.

COMBINATIONS

Model			M-VR-OV-1908-SG	M-VR-OV-1962-SG	M-VR-OV-2016-SG	M-VR-OV-2072-SG
Power		HP	68	70	72	74
Combination			280+450+560+615	280+500+560+615	280+560+560+615	280+560+615+615
Rated capacity	Cooling	kW	190.50	195.90	201.50	2070
Nominal absorbed power		kW	52.28	53.81	56.64	59.35
Energy efficiency coefficient (nominal)		EER1	3.64	3.64	3.56	3.49
Rated capacity	Heating	kW	213.50	220.00	226.50	232.50
Nominal absorbed power		kW	54.82	56.84	59.06	60.75
Energy performance coefficient (nominal)		COP1	3.89	3.87	3.83	3.83
Electrical Data						
Power supply		Ph-V-Hz	3-380~415-50			
Maximum current		A	159.80	167.50	168.50	169.50
Refrigerant Circuit Data						
Refrigerant2		type (GWP)	R410A (2088)			
Q.ty of refrigerant pre-charge 3 (tons of CO2 equivalent)		Kg	46.2 (96.47)	47.4 (98.98)	47.4 (98.98)	47.9 (100.02)
Compressor		nb. / type	6 / Scroll DC Inverter		7 / Scroll DC Inverter	
Piping diameter4	Liquid	mm (inch)	22.2 (7/8")	22.2 (7/8")	22.2 (7/8")	22.2 (7/8")
	Gas HP	mm (inch)	41.3 (1-5/8")	41.3 (1-5/8")	41.3 (1-5/8")	41.3 (1-5/8")
	Gas LP	mm (inch)	44.5 (1-3/4")	44.5 (1-3/4")	44.5 (1-3/4")	44.5 (1-3/4")
Product Specifications						
Dimensions5		WxHxD	5250x1690x775	5250x1690x775	5250x1690x775	5250x1690x775
Net weight		Kg	1338	1398	1398	1398
Volume of air treated		max	m3/h	58900	60000	60000
Available static pressure		std/max	Pa	0/110	0/110	0/110
Operating range (outdoor temperature)	Cooling	°C	-10~55	-10~55	-10~55	-10~55
	Heating	°C	-25~24	-25~24	-25~24	-25~24
	Hydronic heating	°C	-20~24	-20~24	-20~24	-20~24
	Domestic hot water (DHW)	°C	-20~35	-20~35	-20~35	-20~35
Connectable air-to-air indoor units (max)		nb.	80	80	80	80
Connectable air-to-water hydronic modules (max)6		nb.	6	6	6	6
Capacity of connectable air-to-air indoor units		%	50 ~ 135			
Accessories						
Branch pipe kit for O.U. pairing		nb. / type	1 / DOS-68-MW-VR + 2 / DOS-246-MW-VR			

1. Value measured according to harmonized standard EN14511.

2. Refrigerant leakage contributes to climate change. Refrigerants with a lower global warming potential (GWP) contribute less to global warming when released into the atmosphere than those with a higher GWP. This appliance contains a refrigerant with a GWP of 2088. Therefore, if 1 kg of this refrigerant were released into the atmosphere, the impact on global warming would be 2088 times greater than 1 kg of CO2, over a period of 100 years. Under no circumstances should the user attempt to intervene on the refrigerant circuit or disassemble the product. If necessary, always contact qualified personnel.

3. To calculate the additional refrigerant charge, refer to the labels located inside and outside the unit.

4. In combinations of multiple outdoor units, the diameters indicated refer to the section up to the first branch, with an equivalent length of less than 90 m.

5. Space between the combined units = 100 mm.

6. To determine the power of the connectable hydronic modules, consult the installation manual.

COMBINATIONS

M-VR-OV-2128-SG	M-VR-OV-2184-SG	M-VR-OV-2240-SG	M-VR-OV-2295-SG	M-VR-OV-2350-SG	M-VR-OV-2405-SG	M-VR-OV-2460-SG
76	78	80	82	84	86	88
280+615+615+615	335+615+615+615	400+615+615+615	450+615+615+615	500+615+615+615	560+615+615+615	615+615+615+615
212.50	218.00	224.50	229.50	234.90	240.50	246.00
62.05	63.76	65.33	67.02	68.56	71.39	74.10
3.42	3.42	3.44	3.42	3.43	3.37	3.32
238.50	244.50	252.00	257.00	263.50	270.00	276.00
62.44	64.11	66.04	67.67	69.69	71.91	73.60
3.82	3.81	3.82	3.80	3.78	3.75	3.75
3-380~415-50						
170.50	171.10	184.50	186.30	194.00	195.00	196.00
R410A (2088)						
48.4 (101.06)	49.5 (103.35)	51 (106.49)	51.5 (107.53)	52.7 (110.04)	52.7 (110.04)	53.2 (111.08)
7 / Scroll DC Inverter			8 / Scroll DC Inverter			
22.2 (7/8")	22.2 (7/8")	22.2 (7/8")	22.2 (7/8")	22.2 (7/8")	22.2 (7/8")	22.2 (7/8")
41.3 (1-5/8")	41.3 (1-5/8")	41.3 (1-5/8")	41.3 (1-5/8")	41.3 (1-5/8")	41.3 (1-5/8")	41.3 (1-5/8")
44.5 (1-3/4")	44.5 (1-3/4")	44.5 (1-3/4")	44.5 (1-3/4")	44.5 (1-3/4")	44.5 (1-3/4")	44.5 (1-3/4")
5250x1690x775	5250x1690x775	5660x1690x775	5660x1690x775	5660x1690x775	5660x1690x775	5660x1690x775
1398	1411	1480	1480	1540	1540	1540
60000	60600	63000	64900	66000	66000	66000
0/110	0/110	0/110	0/110	0/110	0/110	0/110
-10~-55	-10~-55	-10~-55	-10~-55	-10~-55	-10~-55	-10~-55
-25~-24	-25~-24	-25~-24	-25~-24	-25~-24	-25~-24	-25~-24
-20~-24	-20~-24	-20~-24	-20~-24	-20~-24	-20~-24	-20~-24
-20~-35	-20~-35	-20~-35	-20~-35	-20~-35	-20~-35	-20~-35
80	80	80	80	80	80	80
6	6	6	6	6	6	6
50 ~ 135						
1 / DOS-68-MW-VR + 2 / DOS-246-MW-VR			3 / DOS-246-MW-VR			

1. Value measured according to harmonized standard EN14511.

2. Refrigerant leakage contributes to climate change. Refrigerants with a lower global warming potential (GWP) contribute less to global warming when released into the atmosphere than those with a higher GWP. This appliance contains a refrigerant with a GWP of 2088. Therefore, if 1 kg of this refrigerant were released into the atmosphere, the impact on global warming would be 2088 times greater than 1 kg of CO₂, over a period of 100 years. Under no circumstances should the user attempt to intervene on the refrigerant circuit or disassemble the product. If necessary, always contact qualified personnel.

3. To calculate the additional refrigerant charge, refer to the labels located inside and outside the unit.

4. In combinations of multiple outdoor units, the diameters indicated refer to the section up to the first branch, with an equivalent length of less than 90 m.

5. Space between the combined units = 100 mm.

6. To determine the power of the connectable hydronic modules, consult the installation manual.

FLOW CONTROLLERS

M-VR-ME-1-NG

M-VR-ME-2-NG

M-VR-ME-4-NG

M-VR-ME-8-NG

Model				M-VR-ME-1-NG	M-VR-ME-2-NG	M-VR-ME-4-NG	M-VR-ME-8-NG
Pairs of connections for indoor units		q.ty		1	2	4	8
Max. number of connectable indoor units	for each pair of connections ¹			8	8	8	8
	for each flow controller			8	16	32	64
Max. capacity of connectable indoor units	for each pair of connections ²	kW		16.00	16.00	16.00	16.00
	for each flow controller ³	kW		16.00	28.00	45.00	85.00
Electrical Data							
Power supply		Ph-V-Hz		1-220~240V-50Hz			
Refrigerant Circuit Data							
Piping diameter (a saldare)	Outdoor unit side	Liquid	mm (inch)	9.52 (3/8")	9.52 (3/8")	12.7 (1/2")	12.7 (1/2")
		Gas HP	mm (inch)	19.05 (3/4")	19.05 (3/4")	22.2 (7/8")	22.2 (7/8")
		Gas LP	mm (inch)	22.2 (7/8")	22.2 (7/8")	28.6 (1-1/8")	28.6 (1-1/8")
	Indoor uni side	Liquid	mm	6.35 / 9.52	6.35 / 9.52	6.35 / 9.52	6.35 / 9.52
		Gas	mm	12.7 / 15.9	12.7 / 15.9	12.7 / 15.9	12.7 / 15.9
Product Specifications							
Dimensions		WxHxD	mm	340x250x388	340x250x388	460x250x388	784x250x388
Net weight			Kg	12	14.5	20.6	33
Condensate drain				Necessary	Necessary	Necessary	Necessary

1. Any indoor units connected to the same pair of connections must operate in the same operating mode.

2. I.U.s with capacities from 16 to 30 kW can be connected to the heat cost allocators with 2 to 8 connections, using the DIS-180-1 branch kit which occupies 2 pairs of connections.

3. In case of connection of hydronic modules, the maximum capacity increases to 32 kW (2 connections), 64 kW (4 connections) and 96 kW (8 connections).

HYDRONIC MODULE



M-VR-HM-16-NG
M-VR-HM-30-NG

Model			M-VR-HM-16-NG	M-VR-HM-30-NG
Rated capacity	Domestic hot water	kW	4.50 (3.60~16.00)	4.50 (3.60~30.00)
	Hydronic heating	kW	16.00	30.00
Maximum delivery water temperature		°C	55	55
Electrical Data				
Power supply		Ph-V-Hz	1-220~240-50Hz	
Hydraulic Data				
Water/freon heat exchanger	Brand	type	Braze-welded plates	
	Water flow	m ³ /h	2.76	5.16
	Pressure drop	kPa	27.5	38.5
Circulation pump			Not included	
Water connections	Diameter	mm	25	25
	Thread	Inch	G1	G1
Operating pressure Min/Max	Max	bar	3	3
Expansion vessel			Not included	
Refrigerant Circuit Data				
Piping diameter	Liquid	mm (inch)	9.52 (3/8")	9.52 (3/8")
	Gas		15.9 (5/8")	22.2 (7/8")
Product Specifications				
Dimensions	WxHxD	mm	515x606x330	515x606x330
Net weight		kg	36	40
Condensate drain				Necessary
Controls	Wired control			Included
	Climate curve			Available
Accessories				
Branch pipe kit for connection to flow divider			-	DIS-180-1

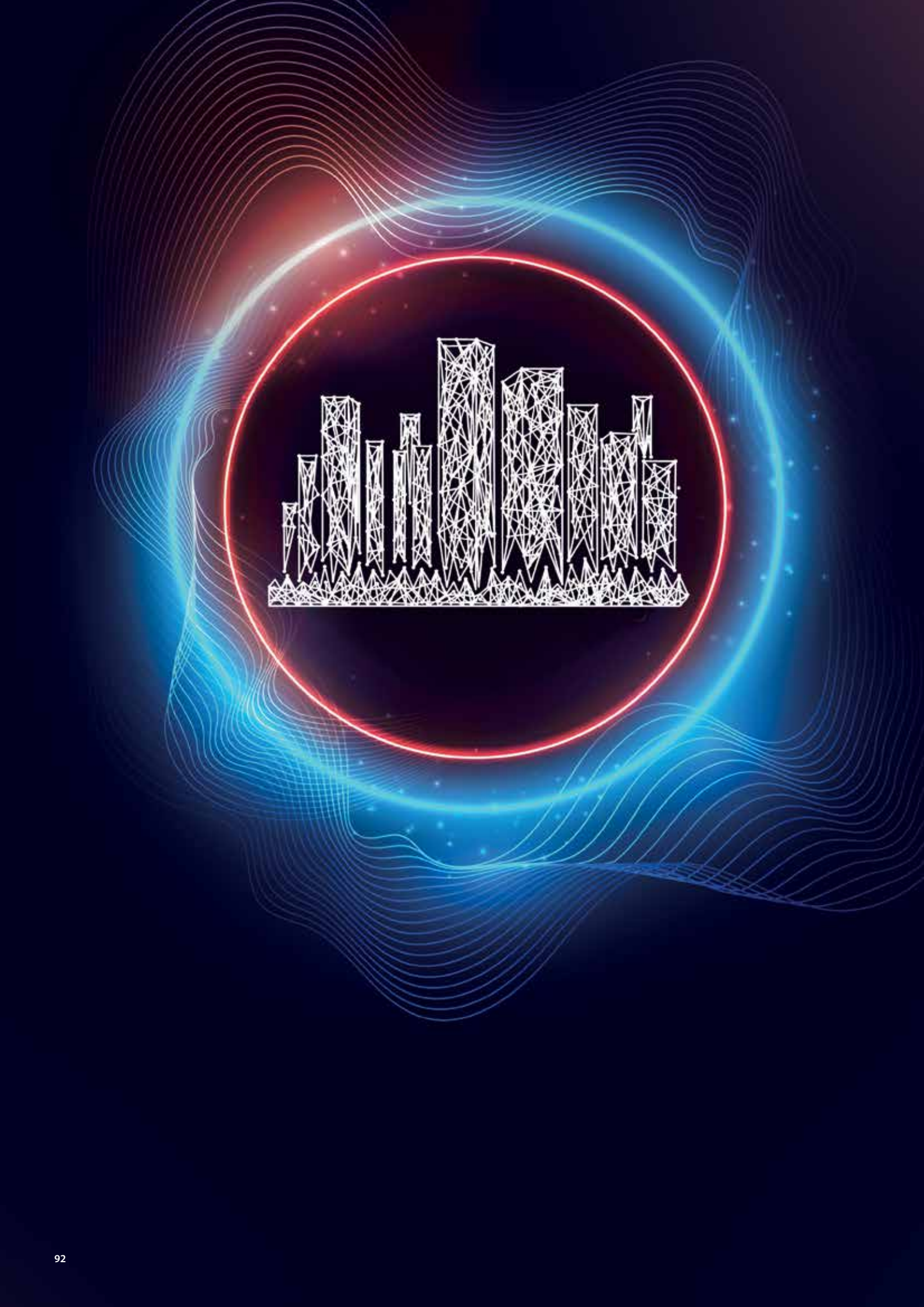

INDOOR UNITS











MW MINI, MW 2-PIPE, MW 3-PIPE SYSTEMS

- 95 > **LINE UP INDOOR UNITS**
- 96 > **WALL**
- 97 > **8-WAY COMPACT CASSETTE**
- 98 > **8-WAY CASSETTE**
- 99 > **DUCTED LOW/MEDIUM STATIC PRESSURE**
- 100 > **DUCTED HIGH STATIC PRESSURE**
- 101 > **CONSOLE**
- 102 > **FLOOR/CEILING**
- 103 > **RECESSED FLOOR**
- 104 > **DUCTED WITH ALL-OUTSIDE AIR**
- 105 > **ENTHALPY HEAT RECOVERY WITH COIL**
- 106 > **AHU CONNECTION KIT**



INDOOR UNITS

MW MINI, MW 2-PIPE, MW 3-PIPE SYSTEMS

		kW	1.50	2.20	2.80	3.60	4.50	5.60	7.10	9.00	11.20	12.50	14.00	16.00	18.00	22.40	28.00
Wall	 M-V-WLA-G	✓	✓	✓	✓	✓	✓	✓	✓								
8-Way Compact Cassette	 M-V-CSA-G	✓	✓	✓	✓	✓	✓	✓									
8-Way Cassette	 M-V-CBA-G								✓	✓	✓		✓				
Ducted low/medium static pressure	 M-V-DLA-G		✓	✓	✓	✓	✓	✓									
Ducted high static pressure	 M-V-DHA-G								✓	✓	✓		✓				
Ducted high static pressure	 M-V-DHA-G															✓	✓
Console	 M-V-CNA-G		✓	✓	✓	✓	✓	✓									
Floor/ceiling	 M-V-FCA-G					✓		✓	✓	✓	✓		✓				
Recessed floor	 M-V-FYA-G		✓	✓	✓	✓	✓	✓	✓								
Ducted with all-outside air	 M-V-DFA-NG											✓	✓				
Enthalpy heat recovery with coil	 M-V-THE-DX-NG									✓		✓	✓				
										500mc/h		800mc/h	1000mc/h				

WALL

7 CAPACITIES
1.50~7.10 kW

ELEGANT & COMPACT DESIGN
209 mm depth for models from
1.50 to 3.60 kW

WASHABLE FILTER
better air quality

SELF-DIAGNOSIS

CONTROLS
standard remote control
optional wired control

M-V-WLA-151~711-G



Model	M-V-WLA-151-G		M-V-WLA-221-G		M-V-WLA-281-G	
Control (included)			Remote control			
Rated capacity	Cooling	kW	1.50	2.20	2.80	
	Heating	kW	1.80	2.50	3.20	
Electrical data						
Power supply	Ph-V-Hz		1-220~240V-50Hz			
Power absorption	W		20	20	20	
Product specifications						
Dimensions	WxHxD	mm	845x289x209	845x289x209	845x289x209	
Net weight			10.5	10.5	10.5	
Sound pressure level at 1 m	H/M/L	dB(A)	35/33/30	35/33/30	35/33/30	
Volume of air treated	H/M/L	m ³ /h	500/440/300	500/440/300	500/440/300	
Connection diameter	Liquid/Gas	mm (inch)	6.35 (1/4") / 9.52 (3/8")			
	Condensate	mm	20	20	20	
Optional parts						
Wired control	M-V-CW-SD1-G (LCD) / M-V-CW-TW1-G (touch) / M-V-CW-HB2-G (simplified)					
Centralized control	M-V-CC-T255-G2 / M-V-CC-T32-G (simplified)					

Model	M-V-WLA-361-G		M-V-WLA-451-G		M-V-WLA-561-G		M-V-WLA-711-G	
Control (included)					Remote control			
Rated capacity	Cooling	kW	3.60	4.50	5.60	7.10		
	Heating	kW	4.00	5.00	6.30	7.50		
Electrical data								
Power supply	Ph-V-Hz		1-220~240V-50Hz					
Power absorption	W		25	35	50	65		
Product specifications								
Dimensions	WxHxD	mm	845x289x209	970x300x224	1078x325x246	1078x325x246		
Net weight			10.5	12.5	16	16		
Sound pressure level at 1 m	H/M/L	dB(A)	38/35/31	43/40/37	43/41/37	44/41/37		
Volume of air treated	H/M/L	m ³ /h	630/460/320	850/580/500	1100/850/650	1200/850/650		
Connection diameter	Liquid/Gas	mm (inch)	6.35 (1/4") / 12.74 (1/2")			9.52 (3/8") / 15.9 (5/8")		
	Condensate	mm	20	20	20	20		
Optional parts								
Wired control	M-V-CW-SD1-G (LCD) / M-V-CW-TW1-G (touch) / M-V-CW-HB2-G (simplified)							
Centralized control	M-V-CC-T255-G2 / M-V-CC-T32-G (simplified)							

8-WAY COMPACT CASSETTE 60x60

6 CAPACITIES
1.50~5.60 kW

COMPACT DESIGN
265 mm height for recessed installation in false ceilings

360° AIR DISTRIBUTION

WASHABLE FILTER
better air quality

CONDENSATE DRAIN PUMP INCLUDED

maximum height difference
1200 mm from panel edge

CONTROLS
standard remote control
optional wired control

M-V-CSA-151~561-G



Model	M-V-CSA-151-G		M-V-CSA-221-G		M-V-CSA-281-G	
Control (included)			Remote control			
Rated capacity	Cooling	kW	1.50	2.20	2.80	
	Heating	kW	1.80	2.50	3.20	
Electrical data						
Power supply	Ph-V-Hz		1-220~240V-50Hz			
Power absorption	W		30	30	30	
Product specifications						
Dimensions	WxHxD	mm	570x265x570	570x265x570	570x265x570	
Net weight			17.5	17.5	17.5	
Sound pressure level at 1 m	H/M/L	dB(A)	33/30/25	36/31/25	36/33/28	
Volume of air treated	H/M/L	m³/h	460/420/370	500/460/370	570/480/420	
Connection diameter	Liquid/Gas	mm (inch)	6.35 (1/4") / 9.52 (3/8")			
	Condensate	mm	25	25	25	
Accessories						
Decorative panel			M-V-CGR-608-G			
Panel dimensions	WxHxD	mm	620x47.5x620	620x47.5x620	620x47.5x620	
Net weight	Kg		3	3	3	
Optional parts						
Wired control	M-V-CW-SD1-G (LCD) / M-V-CW-TW1-G (touch) / M-V-CW-HB2-G (simplified)					
Centralized control	M-V-CC-T255-G2 / M-V-CC-T32-G (simplified)					

Model	M-V-CSA-361-G		M-V-CSA-451-G		M-V-CSA-561-G	
Control (included)			Remote control			
Rated capacity	Cooling	kW	3.60	4.50	5.60	
	Heating	kW	4.00	5.00	6.30	
Electrical data						
Power supply	Ph-V-Hz		1-220~240V-50Hz			
Power absorption	W		30	45	45	
Product specifications						
Dimensions	WxHxD	mm	570x265x570	570x265x570	570x265x570	
Net weight			17.5	17.5	17.5	
Sound pressure level at 1 m	H/M/L	dB(A)	39/37/35	43/41/39	43/41/39	
Volume of air treated	H/M/L	m³/h	620/550/480	730/650/560	730/650/560	
Connection diameter	Liquid/Gas	mm (inch)	6.35 (1/4") / 12.74 (1/2")		9.52 (3/8") / 15.9 (5/8")	
	Condensate	mm	25	25	25	
Accessories						
Decorative panel			M-V-CGR-608-G			
Panel dimensions	WxHxD	mm	620x47.5x620	620x47.5x620	620x47.5x620	
Net weight	Kg		3	3	3	
Optional parts						
Wired control	M-V-CW-SD1-G (LCD) / M-V-CW-TW1-G (touch) / M-V-CW-HB2-G (simplified)					
Centralized control	M-V-CC-T255-G2 / M-V-CC-T32-G (simplified)					

8-WAY CASSETTE 84x84

4 CAPACITIES
7.10~14.00 kW

ULTRA COMPACT DESIGN
only **200 mm** high for the 7.10 kW model
for installation in false ceilings

WASHABLE FILTER
better air quality

CONDENSATE DRAIN PUMP INCLUDED
maximum height difference **1200 mm**
from panel edge

CONTROLS
standard remote control
optional wired control



M-V-CBA-712~1402-G



Model			M-V-CBA-712-G		M-V-CBA-902-G	
Control (included)			Remote control			
Rated capacity	Cooling	kW	7.10		9.00	
	Heating	kW	8.00		10.00	
Electrical data						
Power supply		Ph-V-Hz	1-220~240V-50Hz			
Power absorption		W	60		75	
Product specifications						
Dimensions	WxHxD	mm	840x200x840		840x240x840	
Net weight		Kg	21		22.5	
Sound pressure level at 1 m	H/M/L	dB(A)	37/35/32		40/36/31	
Volume of air treated	H/M/L	m ³ /h	1100/935/850		1400/1000/900	
Connection diameter	Liquid/Gas	mm (inch)	25		9.52 (3/8") / 15.9 (5/8")	
	Condensate	mm	25		25	
Accessories						
Decorative panel			M-V-CGR-848-G			
Panel dimensions	WxHxD	mm	950x65x950		950x65x950	
Net weight		Kg	6		6	
Optional parts						
Wired control			M-V-CW-SD1-G (LCD) / M-V-CW-TW1-G (touch) / M-V-CW-HB2-G (simplified)			
Centralized control			M-V-CC-T255-G2 / M-V-CC-T32-G (simplified)			

Model			M-V-CBA-1122-G		M-V-CBA-1402-G	
Control (included)			Remote control			
Rated capacity	Cooling	kW	11.20		14.00	
	Heating	kW	12.50		16.00	
Electrical data						
Power supply		Ph-V-Hz	1-220~240V-50Hz			
Power absorption		W	100		160	
Product specifications						
Dimensions	WxHxD	mm	840x240x840		840x290x840	
Net weight		Kg	22.5		25	
Sound pressure level at 1 m	H/M/L	dB(A)	43/39/35		46/41/35	
Volume of air treated	H/M/L	m ³ /h	1550/1200/1000		1800/1450/1150	
Connection diameter	Liquid/Gas	mm (inch)	25		9.52 (3/8") / 15.9 (5/8")	
	Condensate	mm	25		25	
Accessories						
Decorative panel			M-V-CGR-848-G			
Panel dimensions	WxHxD	mm	950x65x950		950x65x950	
Net weight		Kg	6		6	
Optional parts						
Wired control			M-V-CW-SD1-G (LCD) / M-V-CW-TW1-G (touch) / M-V-CW-HB2-G (simplified)			
Centralized control			M-V-CC-T255-G2 / M-V-CC-T32-G (simplified)			

DUCTED LOW/MEDIUM STATIC PRESSURE

5 CAPACITIES
2.20~5.60 kW

WASHABLE FILTER
better air quality

CONDENSATE DRAIN PUMP INCLUDED
maximum height difference **850 mm**
from the exit hole

Ideal for cooling and heating small and medium-sized rooms

COMPACT MODEL
only **200 mm** high, **710 mm** wide and **462 mm** deep (2.20~3.60 kW)

CONTROLS
wired control included

M-V-DLA-222~562-G



Model			M-V-DLA-222-G	M-V-DLA-282-G	M-V-DLA-362-G
Control (included)			Wired control		
Rated capacity	Cooling	kW	2.20	2.80	3.60
	Heating	kW	2.50	3.20	4.00
Electrical data					
Power supply		Ph-V-Hz	1-220~240V-50Hz		
Power absorption		W	78	78	78
Product specifications					
Dimensions	WxHxD	mm	710x200x462	710x200x462	710x200x462
Net weight		Kg	18.5	18.5	19.0
Sound pressure level at 1 m	H/M/L	dB(A)	30/25/22	30/25/22	31/27/25
Volume of air treated	H/M/L	m ³ /h	450/350/200	450/350/200	550/400/300
Fan static pressure	Std/Max	Pa	15/30	15/30	15/30
Connection diameter	Liquid/Gas	mm (inch)	6.35 (1/4") / 9.52 (3/8")		6.35 (1/4") / 12.74 (1/2")
	Condensate	mm	25	25	25
Optional parts					
Centralized control			M-V-CC-T255-G2 / M-V-CC-T32-G (simplified)		

Model			M-V-DLA-452-G	M-V-DLA-562-G
Control (included)			Wired control	
Rated capacity	Cooling	kW	4.50	5.60
	Heating	kW	5.00	6.30
Electrical data				
Power supply		Ph-V-Hz	1-220~240V-50Hz	
Power absorption		W	78	117
Product specifications				
Dimensions	WxHxD	mm	1010x200x462	1010x200x462
Net weight		Kg	24.0	25.0
Sound pressure level at 1 m	H/M/L	dB(A)	33/29/27	35/31/29
Volume of air treated	H/M/L	m ³ /h	750/550/400	850/700/550
Fan static pressure	Std/Max	Pa	15/30	15/30
Connection diameter	Liquid/Gas	mm (inch)	6.35 (1/4") / 12.74 (1/2")	
	Condensate	mm	25	25
Optional parts				
Centralized control			M-V-CC-T255-G2 / M-V-CC-T32-G (simplified)	

DUCTED HIGH STATIC PRESSURE

6 CAPACITIES
7.10~28.00 kW

WASHABLE FILTER
better air quality

Ideal for cooling and heating medium
and large sized rooms

CONTROLS
wired control included

ULTRA COMPACT DESIGN
only **300 mm** high for the
7.10 and 18.00 kW models

**CONDENSATE DRAIN PUMP
INCLUDED** maximum height
difference **1100 mm** from the outlet
hole for models from 7.10 to 18.00 kW

5 FAN SPEEDS
auto, low, med, high, turbo

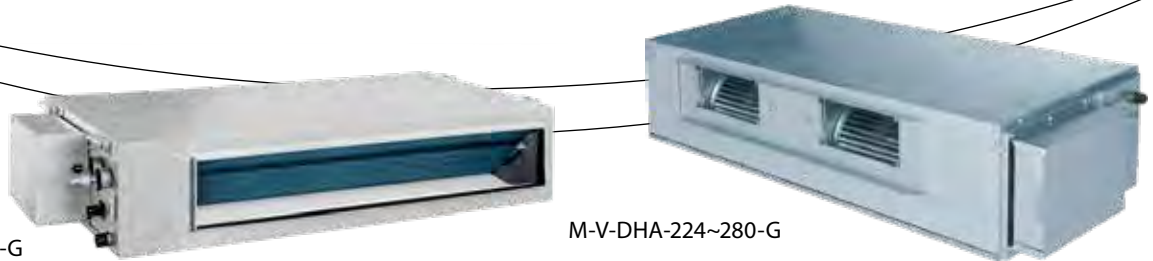

M-V-DHA-711~1401-G

M-V-DHA-224~280-G

Model			M-V-DHA-711-G	M-V-DHA-901-G	M-V-DHA-1121-G	M-V-DHA-1401-G
Control (included)			Wired control			
Rated capacity	Cooling	kW	7.10	9.00	11.20	14.00
	Heating	kW	8.00	10.00	12.50	16.00
Electrical data						
Power supply		Ph-V-Hz	1-220~240V-50Hz			
Power absorption		W	100	140	160	220
Product specifications						
Dimensions	WxHxD	mm	1000x300x700	1400x300x700	1400x300x700	1400x300x700
Net weight		Kg	43	57	57	58
Sound pressure level at 1 m	H/M/L	dB(A)	38/36/34	40/37/35	40/38/36	42/39/37
Volume of air treated	H/M/L	m³/h	1250/1050/950	1800/1450/1250	2000/1600/1400	2350/1900/1650
Fan static pressure	Std/Max	Pa	90/200	90/200	90/200	90/200
Connection diameter	Liquid/Gas	mm (inch)	9.52 (3/8") / 15.9 (5/8")			
	Condensate	mm	25	25	25	25
Optional parts						
Centralized control			M-V-CC-T255-G2 / M-V-CC-T32-G (simplified)			

Model			M-V-DHA-224-G	M-V-DHA-280-G
Control (included)			Wired control	
Rated capacity	Cooling	kW	22.40	28.00
	Heating	kW	25.00	31.00
Electrical data				
Power supply		Ph-V-Hz	1-220~240V-50Hz	
Power absorption		W	800	900
Product specifications				
Dimensions	WxHxD	mm	1483x385x791	1686x450x870
Net weight		Kg	82	105
Sound pressure level at 1 m	H/M/L	dB(A)	54/52/49	55/52/50
Volume of air treated	H/M/L	m³/h	4000/3600/3200	4400/4000/3600
Fan static pressure	Std/Max	Pa	100/200	100/200
Connection diameter	Liquid/Gas	mm (inch)	9.52 (3/8") / 19.05 (3/4")	
	Condensate	mm	25	
Optional parts				
Centralized control			M-V-CC-T255-G2 / M-V-CC-T32-G (simplified)	

CONSOLE

5 CAPACITIES

2.20~5.00 kW

LOW SOUND IMPACT

only **27 dB(A)** for the 2.20 and 2.80 kW models

SELF-DIAGNOSIS

I FEEL FUNCTION

CONTROLS

remote control included
optional wired control

M-V-CNA-22~50-G



Model			M-V-CNA-22-G		M-V-CNA-28-G	
Control (included)			Remote control			
Rated capacity	Cooling	kW	2.20		2.80	
	Heating	kW	2.50		3.20	
Electrical data						
Power supply		Ph-V-Hz	1-220~240V-50Hz			
Power absorption		W	15		15	
Product specifications						
Dimensions	WxHxD	mm	700x600x215		700x600x215	
Net weight		Kg	16		16	
Sound pressure level at 1 m	H/M/L	dB(A)	38/33/27		38/33/27	
Volume of air treated	H/M/L	m ³ /h	400/320/270		400/320/270	
Connection diameter	Liquid/Gas	mm (inch)	6.35 (1/4) / 9.52 (3/8)			
	Condensate	mm	28		28	
Optional parts						
Wired control			M-V-CW-SD1-G (LCD) / M-V-CW-TW1-G (touch) / M-V-CW-HB2-G (simplified)			
Centralized control			M-V-CC-T255-G2 / M-V-CC-T32-G (simplified)			

Model			M-V-CNA-36-G		M-V-CNA-45-G		M-V-CNA-50-G	
Control (included)			Remote control					
Rated capacity	Cooling	kW	3.60		4.50		5.00	
	Heating	kW	4.00		5.00		5.50	
Electrical data								
Power supply		Ph-V-Hz	1-220~240V-50Hz					
Power absorption		W	20		40		40	
Product specifications								
Dimensions	WxHxD	mm	700x600x215		700x600x215		700x600x215	
Net weight		Kg	16		16		16	
Sound pressure level at 1 m	H/M/L	dB(A)	40/37/32		46/43/39		46/43/39	
Volume of air treated	H/M/L	m ³ /h	480/400/300		680/600/500		680/600/500	
Connection diameter	Liquid/Gas	mm (inch)	6.35 (1/4) / 12.74 (1/2)					
	Condensate	mm	28		28		28	
Optional parts								
Wired control			M-V-CW-SD1-G (LCD) / M-V-CW-TW1-G (touch) / M-V-CW-HB2-G (simplified)					
Centralized control			M-V-CC-T255-G2 / M-V-CC-T32-G (simplified)					

FLOOR/CEILING

6 CAPACITIES

3.60~14.00 kW

COMPACT DESIGN

235 mm height for all models

WASHABLE FILTER

better air quality

I FEEL FUNCTION

SELF-DIAGNOSIS

CONTROLS

remote control included

optional wired control

M-V-FCA-361~1401-G



Model			M-V-FCA-361-G	M-V-FCA-561-G	M-V-FCA-711-G
Control (included)			Remote control		
Rated capacity	Cooling	kW	3.60	5.60	7.10
	Heating	kW	4.00	6.30	8.00
Electrical data					
Power supply		Ph-V-Hz	1-220~240V-50Hz		
Power absorption		W	40	75	75
Product specifications					
Dimensions	WxHxD	mm	870x235x665	870x235x665	1200x 235x665
Net weight		Kg	25	31	31
Sound pressure level at 1 m	H/M/L	dB(A)	36/32/28	44/41/38	44/41/38
Volume of air treated	H/M/L	m ³ /h	650/610/530/460	850/800/700/600	1300/1220/1090/940
Connection diameter	Liquid/Gas	mm (inch)	6.35 (1/4") / 12.74 (1/2")		9.52 (3/8") / 15.9 (5/8")
	Condensate	mm	17		17
Optional parts					
Wired control			M-V-CW-SD1-G (LCD) / M-V-CW-TW1-G (touch) / M-V-CW-HB2-G (simplified)		
Centralized control			M-V-CC-T255-G2 / M-V-CC-T32-G (simplified)		

Model			M-V-FCA-901-G	M-V-FCA-1121-G	M-V-FCA-1401-G
Control (included)			Remote control		
Rated capacity	Cooling	kW	9.00	11.20	14.00
	Heating	kW	10.00	12.50	16.00
Electrical data					
Power supply		Ph-V-Hz	1-220~240V-50Hz		
Power absorption		W	140	160	160
Product specifications					
Dimensions	WxHxD	mm	1200x235x665	1570x235x665	1570x235x665
Net weight		Kg	31	40	42
Sound pressure level at 1 m	H/M/L	dB(A)	47/43/39	47/44/42	50/48/44
Volume of air treated	H/M/L	m ³ /h	1500/1380/1200/1020	1800/1700/1540/1400	2100/2000/1800/1480
Connection diameter	Liquid/Gas	mm (inch)	9.52 (3/8") / 15.9 (5/8")		
	Condensate	mm	17		17
Optional parts					
Wired control			M-V-CW-SD1-G (LCD) / M-V-CW-TW1-G (touch) / M-V-CW-HB2-G (simplified)		
Centralized control			M-V-CC-T255-G2 / M-V-CC-T32-G (simplified)		

RECESSED FLOOR

6 CAPACITIES
2.20~7.10 kW

COMPACT DESIGN
200 mm depth on all capacities

WASHABLE FILTER
better air quality



M-V-FYA-221~711-G



Model			M-V-FYA-221-G	M-V-FYA-281-G	M-V-FYA-361-G
Control (included)			Wired control		
Rated capacity	Cooling	kW	2.20	2.80	3.60
	Heating	kW	2.50	3.20	4.00
Electrical data					
Power supply		Ph-V-Hz	1-220~240V-50Hz		
Power absorption		W	35	35	43
Product specifications					
Dimensions	WxHxD	mm	700x615x200	700x615x200	700x615x200
Net weight		Kg	23	23	23
Sound pressure level at 1 m	H/M/L	dB(A)	30/28/25	30/28/25	33/31/28
Volume of air treated	H/M/L	m ³ /h	450/350/250	450/350/250	550/450/350
Fan static pressure	Std/Max	Pa	10/40	10/40	10/40
Connection diameter	Liquid/Gas	mm (inch)	6.35 (1/4) / 9.52 (3/8)		6.35 (1/4) / 12.74 (1/2)
	Condensate	mm	25	25	25
Optional parts					
Centralized control			M-V-CC-T255-G2 / M-V-CC-T32-G (simplified)		

Model			M-V-FYA-451-G	M-V-FYA-561-G	M-V-FYA-711-G
Control (included)			Wired control		
Rated capacity	Cooling	kW	4.50	5.60	7.10
	Heating	kW	5.00	6.30	8.00
Electrical data					
Power supply		Ph-V-Hz	1-220~240V-50Hz		
Power absorption		W	45	80	90
Product specifications					
Dimensions	WxHxD	mm	900x615x200	1100x615x200	1100x615x200
Net weight		Kg	27	32	32
Sound pressure level at 1 m	H/M/L	dB(A)	33/31/28	35/33/30	37/35/33
Volume of air treated	H/M/L	m ³ /h	650/500/400	900/750/600	1100/900/700
Fan static pressure	Std/Max	Pa	15/60	15/60	15/60
Connection diameter	Liquid/Gas	mm (inch)	9.52 (3/8) / 15.9 (5/8)		
	Condensate	mm	25	25	25
Optional parts					
Centralized control			M-V-CC-T255-G2 / M-V-CC-T32-G (simplified)		

100% OUTDOOR AIR DUCTED

2 CAPACITIES
12.50~14.00 kW

WASHABLE FILTER
better air quality

All-air ducting allows fresh outside air to be introduced into the rooms without causing fluctuations in internal temperature.

CONTROLS
wired control included

M-V-DFA-12520~14020-NG



Model			M-V-DFA-12520-NG	M-V-DFA-14020-NG
Control (included)			Wired control	
Rated capacity	Cooling ¹	kW	12.50	14.00
	Heating ²	kW	8.50	10.00
Electrical data				
Power supply		Ph-V-Hz	1-220~240V-50Hz	
Power absorption		W	200/350	200/350
Product specifications				
Dimensions	WxHxD	mm	1400x300x700	1400x300x700
Net weight		Kg	54	54
Sound pressure level at 1 m	H/M/L	dB(A)	46/50	46/50
Volume of air treated	H/M/L	m ³ /h	1200/2000	1200/2000
Fan static pressure	Std/Max	Pa	150/200	150/200
Connection diameter	Liquid/Gas	mm (inch)	9.52 (3/8") / 15.9 (5/8")	
	Condensate	mm	25	25
Application field (suctioned air temp.)		°C	-7~45 BS	
Optional parts				
Centralized control			M-V-CC-T255-G2 / M-V-CC-T32-G	

1. Conditions: intake air 35°C DB (28°C WB), delivery air 18°C.
2. Conditions: intake air 7°C DB (6°C WB), delivery air 22°C.

ENTHALPY HEAT RECOVERY WITH COIL

3 CAPACITIES
500~1000 m³/h

COMPACT DESIGN
880 mm wide, 340 mm high and
1700 mm deep for the 500 m³/h model

LOW SOUND IMPACT
55 dB(A) for the 500 m³/h model

FAN SPEED
5 + automatic

DAILY TIMER
FILTER AND HEAT EXCHANGER
easily removable

FILTER CLEANING
filter cleaning and
replacement reminder
HIGH degree of filtration

M-V-THE-DX-500~1000-NG



Model	M-V-THE-DX-500-NG		M-V-THE-DX-800-NG		M-V-THE-DX-1000-NG	
Control (included)			Wired control			
Rated capacity	Cooling ¹	kW	8.50	12.00	14.50	
	Heating ²	kW	4.00	10.60	12.00	
Heat exchange efficiency		%	73	74	73	
Electrical data						
Power supply	Ph-V-Hz		1-220~240V-50Hz			
Power absorption	W		270	440	640	
Product specifications						
Dimensions	WxHxD	mm	880x340x1700	1185x390x1800	1185x390x1800	
Net weight		Kg	120	158	158	
Sound power level	Hi	dB(A)	55	59	62	
Sound pressure level at 1 m		dB(A)	41.4	46.1	50.1	
Volume of air treated		m ³ /h	500	800	1000	
Fan static pressure		Pa	150	150	150	
Ducting flange	Diameter	mm	200	250	250	
Connection diameter	Liquid/Gas	mm (inch)	6.35 (1/4") / 12.74 (1/2")	9.52 (3/8") / 15.9 (5/8")	9.52 (3/8") / 15.9 (5/8")	
	Condensate	mm	25	25	25	
Application field (suctioned air temp.)		°C	-25~48 BS			
Optional parts						
Centralized control	M-V-CC-T255-G2 / M-V-CC-T32-G (simplified)					

1. Conditions: indoor air 27° C DB/19.5° C WB; outdoor air 35° C DB/28° C WB.
2. Conditions: indoor air 20° C DB/12° C WB; outdoor air 7° C DB/6° C WB.

CONNECTIVITY LIMITATIONS

50-100%

The sum of the power of the indoor units + the power of the heat recovery unit must be between 50 and 100% of the nominal power of the outdoor unit.

30%

The maximum power of the recovery unit must not exceed 30% of the nominal power of the outdoor unit.

FUNCTIONS AVAILABLE FROM THE CONTROL

Linkage control

Automatic activation of the heat recovery unit via CAN-BUS communication if at least one indoor unit is active; shutdown if all indoor units are off.

Free cooling with automatic bypass

Available when the outside temperature drops below the inside temperature (e.g. during night hours). This function reduces the fan's energy consumption, prolonging the life of the exchanger.

OPERATING MODES

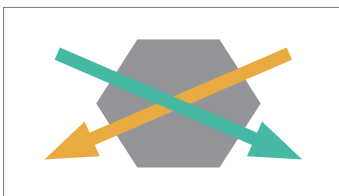

Heat exchange mode

In this mode, the exhaust air and the fresh air enter the exchanger.

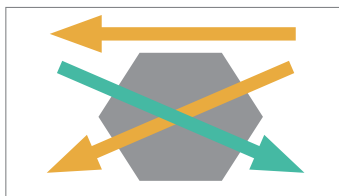

Automatic mode

In this mode the unit automatically regulates the heat exchange.

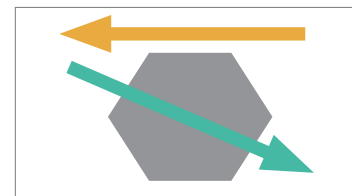

By-pass mode

In this mode the exhaust air does not pass through the exchanger.

AHU CONNECTION KIT

107 > AHU EEV CONNECTION KIT

MECHANICAL VENTILATION

109 > ENTHALPY RECOVERY UNIT

AHU EEV CONNECTION KIT

5 MODELS

3.60~56.00 kW

CLEAN CONTACT

HIGH EFFICIENCY

fewer start & stop cycles of the outdoor unit thanks to VRF technology

ENERGY SAVINGS

using DC Inverter technology

CONTROL

wired control included

M-V-AHU-362~5602-G



Model	M-V-AHU-362-G				M-V-AHU-712-G			M-V-AHU-1402-G				
Control (included)	Wired control				Wired control			Wired control				
Rated capacity	Cooling	kW	3.60		7.10			14.00				
	Heating	kW	4.00		8.00			16.00				
Settable capacity	Cooling	kW	2.80	3.60	4.50	5.60	7.10	9.00	11.20	14.00		
	Heating	kW	3.20	4.00	5.00	6.30	8.00	10.00	12.50	16.00		
Electrical data												
Power supply	Ph-V-Hz	1-220~240V-50Hz				1-220~240V-50Hz			1-220~240V-50Hz			
Power absorption	W	8				8			8			
Product specifications												
EEV kit dimensions	WxHxD	mm	203x85x326				203x85x326			203x85x326		
Control box dimensions	WxHxD	mm	334x111x284				334x111x284			334x111x284		
Net weight		Kg	10				10.5			10.5		
Connection diameter	Liquid from O.U. to kit	mm (inch)	6.35 (1/4")	6.35 (1/4")	9.52 (3/8")	9.52 (3/8")	9.52 (3/8")	9.52 (3/8")	9.52 (3/8")	9.52 (3/8")		
	Liquid from kit to AHU	mm (inch)	6.35 (1/4")	6.35 (1/4")	6.35 (1/4")	9.52 (3/8")	9.52 (3/8")	9.52 (3/8")	9.52 (3/8")	9.52 (3/8")		
	Gas from O.U. to AHU	mm (inch)	9.52 (3/8")	12.7 (1/2")	12.7 (1/2")	15.9 (5/8")	15.9 (5/8")	15.9 (5/8")	15.9 (5/8")	15.9 (5/8")		
Optional parts												
Centralized control	M-V-CC-T255-G2 / M-V-CC-T32-G (simplified)											

Model	M-V-AHU-2802-G						M-V-AHU-5602-G				
Control (included)	Wired control						Wired control				
Rated capacity	Cooling	kW	28.00						56.00		
	Heating	kW	31.50						63.00		
Settable capacity	Cooling	kW	22.40	28.00	33.50	40.00	45.00	50.40	56.00	84.00	
	Heating	kW	25.00	31.50	37.50	45.00	50.00	56.50	63.00	94.50	
Electrical data											
Power supply	Ph-V-Hz	1-220~240V-50Hz						1-220~240V-50Hz			
Power absorption	W	8						8			
Product specifications											
EEV kit dimensions	WxHxD	mm	203x85x326						246x120x500		
Control box dimensions	WxHxD	mm	334x111x284						334x111x284		
Net weight		Kg	10.5						13		
Connection diameter	Liquid from O.U. to kit	mm (inch)	9.52 (3/8")	9.52 (3/8")	9.52 (3/8")	9.52 (3/8")	9.52 (3/8")	15.9 (5/8")	15.9 (5/8")	15.9 (5/8")	
	Liquid from kit to AHU	mm (inch)	9.52 (3/8")	9.52 (3/8")	12.7 (1/2")	12.7 (1/2")	12.7 (1/2")	15.9 (5/8")	15.9 (5/8")	19.05 (3/4")	
	Gas from O.U. to AHU	mm (inch)	19.05 (3/4")	22.2 (7/8")	25.4 (1")	25.4 (1")	28.6 (9/8")	28.6 (9/8")	28.6 (9/8")	31.8 (1-1/4")	
Optional parts											
Centralized control	M-V-CC-T255-G2 / M-V-CC-T32-G (simplified)										

L'EEV-KIT allows, through an electronic expansion valve regulated by an electronic control system (Control Box), the connection of an AHU to the outdoor unit of a VRF system. In this way, you can take advantage of the benefits of VRF technology.

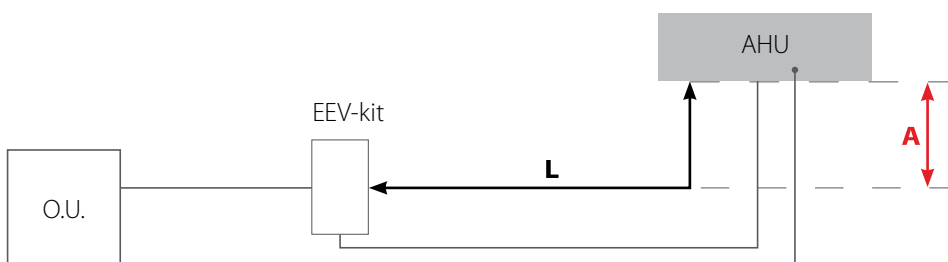

The EEV-kit must be installed in a vertical position 90 ± 15°

- A** The maximum height difference between EEV-kit and AHU is 2 metres.
- L** The maximum distance of the liquid pipe between EEV-kit and AHU is 2 meters. To be considered in the maximum length of the refrigerant pipes.

EEV-KIT

Connectivity

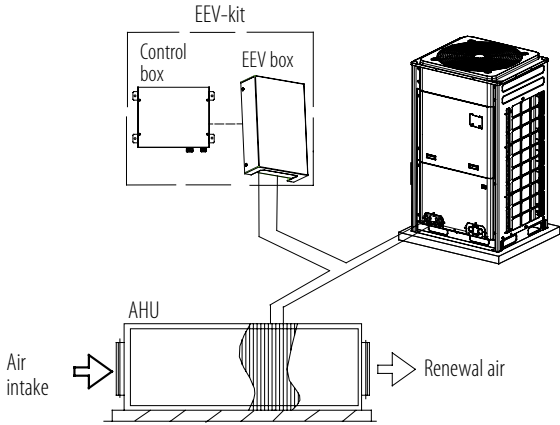

ONE-TO-ONE

An EEV-kit connected with a VRF outdoor unit.
The capacity of the EEV-kit must be between 80% - 110% of the capacity of the outdoor unit.

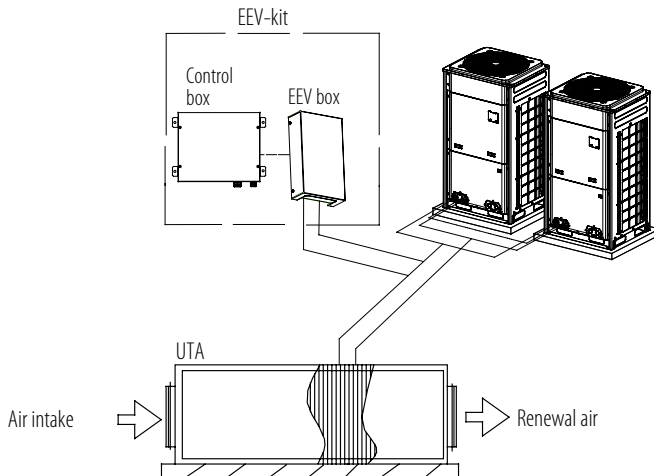

ONE-TO-MORE

An EEV-kit connected with multiple VRF outdoor units.
The capacity of the EEV-kit must be between 50% - 110% of the external capacity.

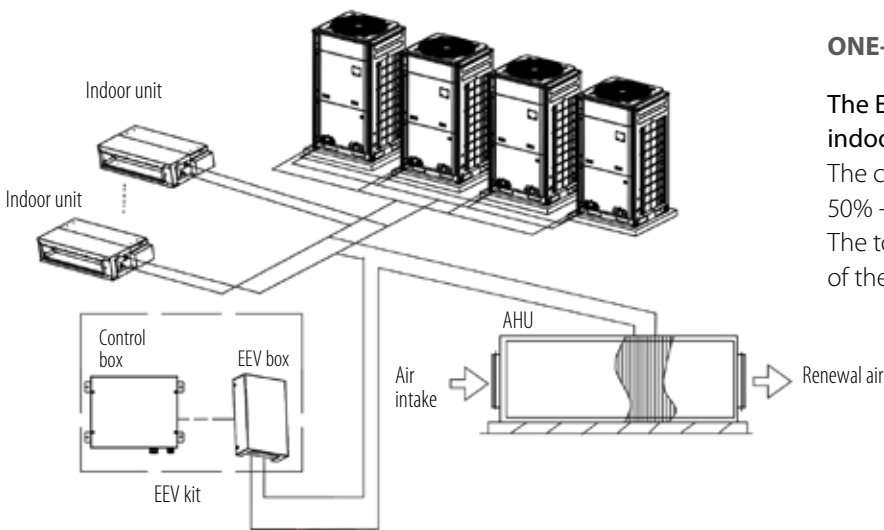

ONE-TO-MORE (MIXED CONNECTION)

The EEV-kit is connected to a VRF system including indoor units.
The capacity of the EEV-kit must be between 50% - 110% of the capacity of the outdoor unit.
The total capacity of the EEV-kit must not exceed 30% of the capacity of the outdoor unit.

ENTHALPY RECOVERY UNIT

4 CAPACITIES
150~500 m³/h

COMPACT DESIGN
1160 mm wide, **220 mm** high and **700 mm** deep for models from 150 to 250 m³/h

LOW SOUND IMPACT
43 dB(A) for the 150 m³/h model

VENTILATION SPEED
5 + automatic

DAILY TIMER

FILTER AND HEAT EXCHANGER
easily removable

FILTER CLEANING
filter cleaning and replacement reminder

HIGH degree of filtration (F7)

CONTROL
wired control included

M-V-THE-150~500-NG2



Model	M-V-THE-150-NG2		M-V-THE-250-NG2		M-V-THE-350-NG2		M-V-THE-500-NG2	
Control (included)	Wired control							
Heat exchange efficiency ¹	%	80	75	76	73			
Electrical data								
Power supply	Ph-V-Hz	1-220~240V-50Hz						
Power absorption	W	50	105	155	250			
Product specifications								
Dimensions	WxHxD	mm	1160x220x700	1160x220x700	1200x240x785	1358x240x785		
Net weight		Kg	50	50	60	71.5		
Sound power level		dB(A)	43	50	55	57		
Volume of air treated		m ³ /h	150	250	350	500		
Fan static pressure		Pa	100	100	100	100		
Ducting flange	Diameter	mm	150	150	150	185		
Application field (suctioned air temp.)		°C	-15~50 DB (max UR 80%)					
Specific energy consumption ²	SEC	kWh/m ² .a	-35.1	-28.7	-	-		
SEC ² Class			A	B	-	-		

Reference standards: Ecodesign Directive EU 1253/2014 for Non-residential ventilation units (NRVU) and residential ventilation units (RVU). Energy Labelling EU 1254/2014 Residential ventilation units (RVU).
1. Values relating to the following conditions: cooling efficiency: indoor air 27° C DB/20° C WB; outdoor air 35° C DB/29° C WB. Heating efficiency: indoor air 20° C DB/14° C WB; outdoor air 5° C DB/2° C WB.
2. Mandatory data only for residential ventilation units (RVU).

INDIVIDUAL USE ENTHALPY HEAT RECOVERY UNIT

Ventilation system that allows the enthalpic recovery of heat from the indoor air. Suitable for residential and commercial applications, it makes the environment healthy and the air clean.

The recovery unit generates energy savings, thanks to the heat and humidity of the expelled air, which are recovered.

Recovery unit operation in winter-summer

The energy contained in the fresh air expelled from the rooms, which would otherwise be dispersed into the atmosphere, is recovered; this is used to pre-heat/pre-cool the air entering from outside.

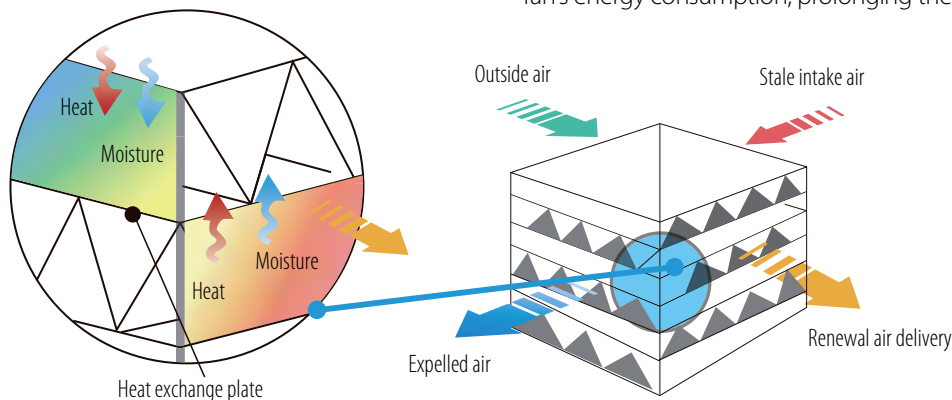

FUNCTIONS AVAILABLE FROM THE CONTROL

Linkage control

Automatic activation of the heat recovery unit via CAN-BUS communication if at least one indoor unit is active; shutdown if all indoor units are off.

Auto control

4 selectable air filtration level settings (excellent, good, moderate, sufficient).

Free cooling with automatic bypass

Available when the outdoor temperature drops below the inside temperature (e.g. during night hours). This function reduces the fan's energy consumption, prolonging the life of the exchanger.

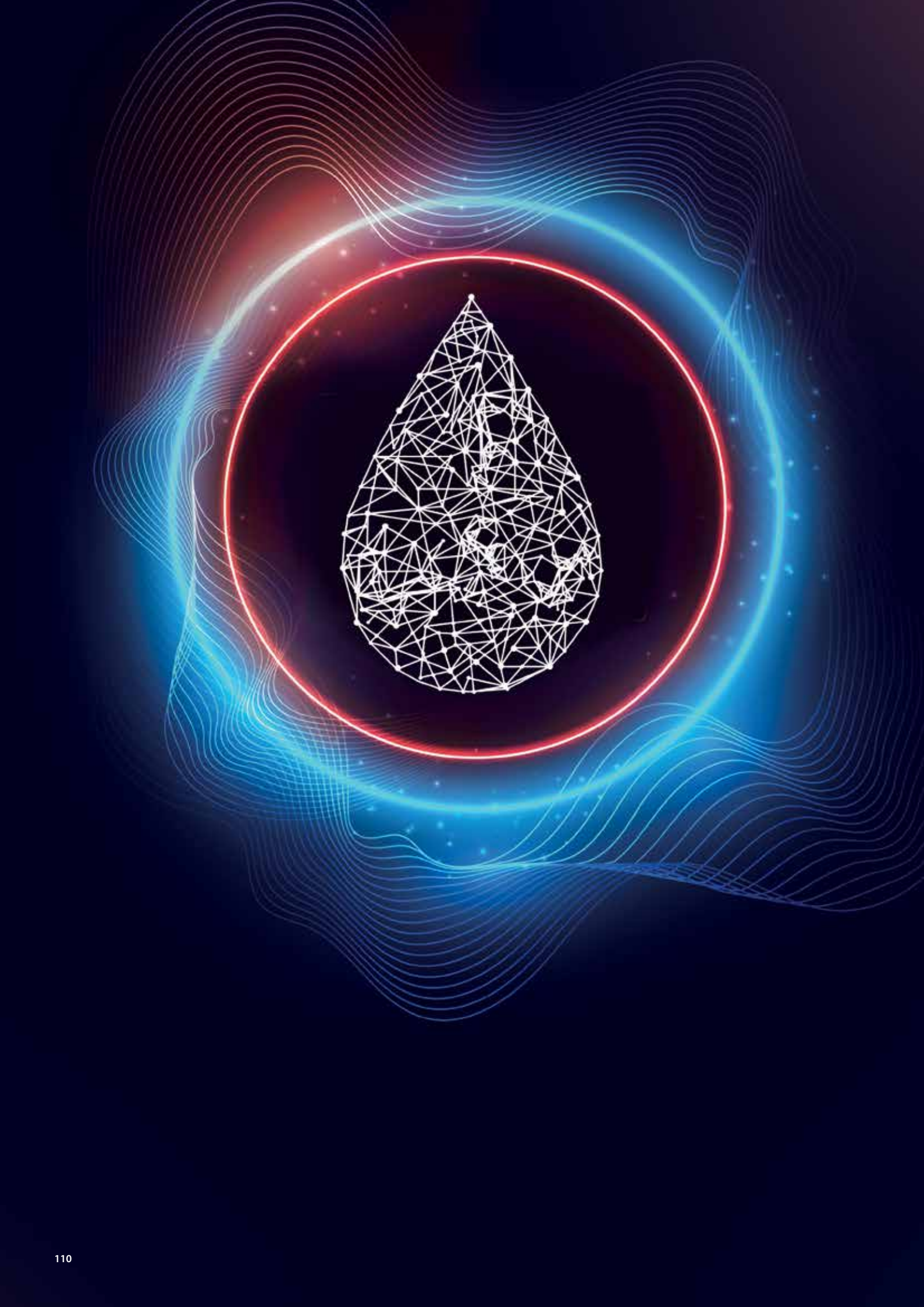

AIR-TO-WATER HEAT PUMP

MONOBLOC MODULAR MONOBLOC AIR-TO-WATER HEAT PUMP SPLIT R32

- 112 **LINE UP MONOBLOC R32**
- 115 > **OUTDOOR UNITS**
- 118 **LINE UP MODULAR MONOBLOC R32**
- 123 > **OUTDOOR UNITS**
- 125 **LINE UP SPLIT R32 WITH HYDROMODULE AND WITH HYDROMODULE AND BUILT-IN TANK**
- 131 > **OUTDOOR UNITS**



MONOBLOC R32

Air-to-water heat pump

OUTDOOR UNITS



5.00 kW	6.00 kW	8.00 kW
1-Phase	1-Phase	1-Phase
MCWNGS 402 Z	MCWNGS 602 Z	MCWNGS 802 Z



10.20 kW	12.00 kW	14.20 kW	15.70 kW
1-Phase	1-Phase	1-Phase	1-Phase
MCWNGS 1002 Z	MCWNGS 1202 Z	MCWNGS 1402 Z	MCWNGS 1602 Z

10.20 kW	12.00 kW	14.20 kW	15.70 kW
3-Phase	3-Phase	3-Phase	3-Phase
MCWSGS 1002 Z	MCWSGS 1202 Z	MCWSGS 1402 Z	MCWSGS 1602 Z

AIR-TO-WATER HEAT PUMP MONOBLOC R32

MONOBLOC by MULTIWARM is the reliable and advantageous solution for heating, cooling and producing DHW in micro-condominiums, single homes and apartments.

The latest generation Full DC Inverter technology guarantees top-of-the-class performance and energy savings, with the added guarantee of the MULTIWARM brand.

65° Delivery temperature, without integrations



Management via EWPE Smart app

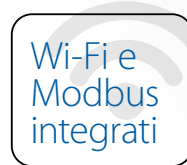

SMART GRID
Reading the trend of the electricity grid, energy savings guaranteed

Heating via radiant floors, fan coils, radiators

Thanks to MULTIWARM's MONOBLOC it is possible to heat all rooms, powering low-temperature hydronic terminals such as radiant floors, and medium-temperature ones, such as fan-coils and high-efficiency radiators.

Main operating modes

- > Cooling, heating, DHW production.
- > Cooling + DHW production (with selectable priority).
- > Heating + DHW production (with selectable priority).
- > DHW production.

Project climate zones for heating

Outside design temp.	Max delivery temp.	Climate zones
+10°C	65°C	WARMER
+5°C	62°C	
+2°C	60°C	
0°	59°C	AVERAGE
-5°C	56°C	
-10°C	53°C	
-15°C	50°C	COLDER
-20°C	47°C	
-25°C	44°C	

MONOBLOC is the R32 heat pump that operates in the following modes:

COOLING MODE

from -15°C to 48°C

from 5°C to 25°C (delivery temp.)

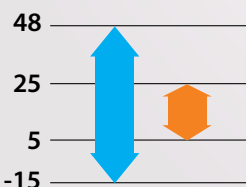

DHW PRODUCTION

from -25°C to 45°C

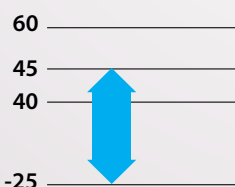

HEATING MODE

from -25°C to 35°C

from 20°C to 65°C (delivery temp.)

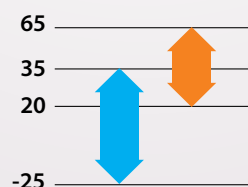

Legend



Outdoor air temperature



Water temperature

MONOBLOC R32

Product benefits



SILENT MODE

Silent mode operation reduces the noise of the heat pump compressor and fan.



CONNECTION WITH OTHER HEAT SOURCES

If the outdoor temperature is lower than the set-point, the external heat source will start operating.



CLIMATE CURVE

Automatically adjusts the water flow temperature and the room temperature based on the outdoor temperature.



EMERGENCY MODE

In the event of a heat pump malfunction, the auxiliary electrical resistors are activated.



ANTI-LEGIONELLA CYCLES

Increase the water temperature up to 70°C using the electric resistance in the DHW storage tank, thus eliminating legionella bacteria and sterilizing the water.



WEEKLY TIMER

Possibility to set up to three daily operating programs (both in heating and cooling).

Compact dimensions

5.00~8.00 kW



10.20~15.70 kW

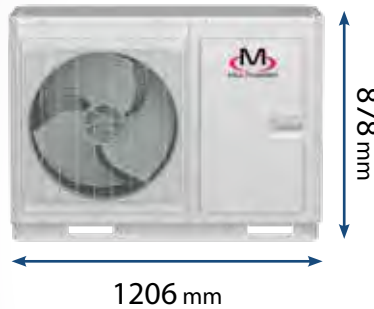

Aluminum fins with anti-corrosion coating (Gold Fin)



The fin coating lasts over time and ensures greater resistance to salt corrosion.



Ease of installation

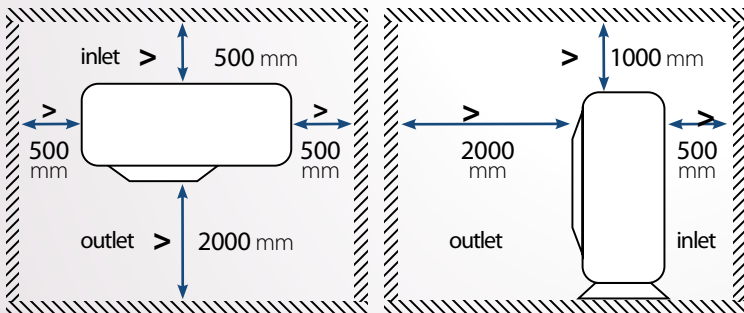

It is not necessary to make any connection to the refrigeration circuit, the hydraulic connections are sufficient.

DMC-HP-Z control

Group control, connect up to four R32 Monobloc or Split Series units, even combined together. Main functions:

- > Silent mode;
- > fast hot water;
- > Holiday mode;
- > Climate;
- > Child lock;
- > anti-legionella programming via electrical resistance in the tank;
- > Error reset;
- > Weekly timer.

System diagram

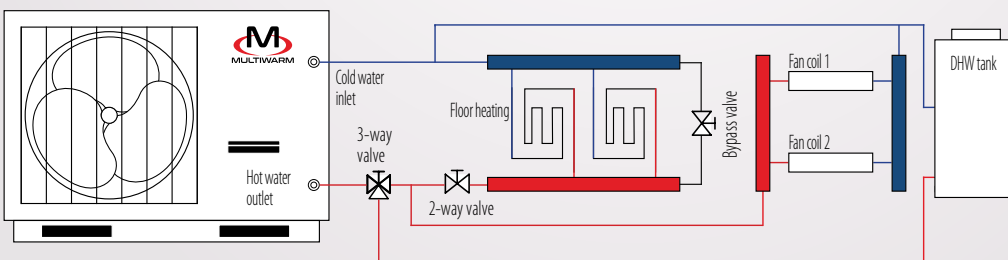

OUTDOOR UNITS



MCWNGS 402 - 602 - 802 Z
1-Phase

ENERGY CLASS

A+++
In heating mode with **35°C**
delivery water temperature.

A++
In heating mode with **55°C**
delivery water temperature.

Model				MCWNGS 402 Z	MCWNGS 602 Z	MCWNGS 802 Z	
Heating	Rated power	A7//W35	kW	5.00	6.00	8.00	
	Electrical absorption			0.93	1.11	1.63	
	Performance coefficient			5.40	5.40	4.90	
	Rated power	A7//W45	kW	4.90	6.80	8.00	
	Electrical absorption			1.17	1.66	2.11	
	Performance coefficient			4.20	4.10	3.80	
Cooling	Rated power	A35//W18	kW	5.00	6.50	8.00	
	Electrical absorption			0.96	1.27	1.65	
	Energy efficiency			5.20	5.10	4.85	
	Rated power	A35//W7	kW	4.90	5.70	7.20	
	Electrical absorption			1.40	1.75	2.25	
	Energy efficiency			3.50	3.25	3.20	
Seasonal heating data	Prated @ -10°C	35/55	kW	5/5	6/5	7/7	
	Seasonal performance coefficient		SCOP	4.88/3.50	5.05/3.50	4.68/3.70	
	Seasonal energy efficiency (ηs)		%	192/137	199/137	184/145	
	Energy efficiency class		-	A+++ / A+++	A+++ / A+++	A+++ / A+++	
	Annual energy consumption		kWh/y	2306/2882	2386/2882	2979/3996	
Operating range	Outdoor air temperature	Heating	°C	-15~48		10~48	
		Cooling					
	Delivery water temperature	Heating		-25~35			
		Cooling		-25~45			
Refrigerant circuit data	Refrigerant ¹	Type (GWP)	R32 (675)				
	Quantity (tons CO2)	kg (t)	0.95 (0.641)		1.23 (0.830)		
	Control system	Electronic expansion valve					
	Compressor	Type	Rotary - DC Inverter				
Hydraulic data	Heat exchanger	Type	With brazed stainless steel plates				
		Flow rate	m³/h	0.7	1.1	1.4	
	Circulation pump	Brand	Shinhoo				
		Static pressure ²	kPa	84	76	60	
	Water connections	Type	Threaded				
		Dimension	Inch	1" F BSP			
	Operating pressure Min/Max			0.5/2.5			
Expansion vessel	Volume	L	2				
	Pre-load	bar	1				
Electrical data	Power supply	Ph/V/Hz		1ph-230V-50Hz			
	Maximum current	Heating	A	11.00	11.00	17.00	
		Cooling		8.00	8.00	10.60	
Power cable (recommended)	Type		3x2.5 mm²		3x4 mm²		
Product specifications	Fan	Type	DC Inverter x 1				
		Air flow	3200				
	Sound power level	dB(A)		58		64	
	Sound pressure level	Heating	dB(A)		53		56
		Cooling			51	52	55
	Dimensions	WxDxH	mm				
Weight	Net	kg		90		95	
Control (supplied)	Wired remote control						

1. Refrigerant leakage contributes to climate change. Refrigerants with a lower global warming potential (GWP) contribute less to global warming when released into the atmosphere than those with a higher GWP. This appliance contains a refrigerant with a GWP of 675. Therefore, if 1 kg of this refrigerant were released into the atmosphere, the impact on global warming would be 675 times greater than 1 kg of CO₂, over a period of 100 years. Under no circumstances should the user attempt to intervene on the refrigerant circuit or disassemble the product. If necessary, always contact qualified personnel. 2. Values net of exchanger pressure drops.

GENERAL NOTE:

The above data refers to the following standards: EN 14511:2018; EN 14825:2019; EN50564:2011; EN12102-1:2018; EN12102-2:2019; (EU)No:811:2013; (EU)No:813:2013; OJ 2014/C 207/02:2014.

OUTDOOR UNITS



MCWNGS 1002 - 1202 - 1402 - 1602 Z
1-Phase

ENERGY CLASS

A+++

In heating mode with **35°C** di delivery water temperature.

A+++

In heating mode with **55°C** delivery water temperature.
10.20 kW model

A++

In heating mode with **55°C** delivery water temperature.
12.00-15.70 kW models

Model				MCWNGS 1002 Z	MCWNGS 1202 Z	MCWNGS 1402 Z	MCWNGS 1602 Z		
Heating	Rated power	A7//W35	kW	10.20	12.00	14.20	15.70		
	Electrical absorption		2.02	2.43	2.99	3.45			
	Performance coefficient		COP	5.05	4.94	4.75	4.55		
	Rated power	A7//W45	kW	10.20	13.00	14.20	16.20		
	Electrical absorption		2.50	3.45	3.84	4.49			
	Performance coefficient		COP	4.08	3.77	3.70	3.61		
Cooling	Rated power	A35//W18	kW	10.20	12.00	13.70	15.50		
	Electrical absorption		2.00	2.45	3.00	3.60			
	Energy efficiency		EER	5.10	4.90	4.57	4.31		
	Rated power	A35//W7	kW	9.00	11.10	13.30	13.80		
	Electrical absorption		2.65	3.58	4.75	5.09			
	Energy efficiency		EER	3.40	3.10	2.80	2.71		
Seasonal heating data	Prated @ -10°C	35/55	kW	9/10	12/12	13/13	14/14		
	Seasonal performance coefficient		SCOP	4.48/3.88	4.78/3.80	4.70/3.75	4.68/3.73		
	Seasonal energy efficiency (ηs)		%	176/152	188/149	185/147	184/146		
	Energy efficiency class		-	A+++/A+++	A+++/A++	A+++/A++	A+++/A+++		
	Annual energy consumption		kWh/y	4163/5486	5194/6388	5682/7352	6072/7675		
Operating range	Outdoor air temperature	Heating	°C	-25~35					
		Cooling		-15~48					
		DHW		-25~45					
	Delivery water temperature	Heating	°C	20~65					
Cooling	5~25								
Refrigerant circuit data	Refrigerant ¹	Type (GWP)	R32 (675)						
	Quantity (tons CO2)	kg (t)	1.6 (1.080)	2.2 (1.485)					
	Control system	Electronic expansion valve							
	Compressor	Type	Rotary - DC Inverter						
Hydraulic data	Heat exchanger	Type	With brazed stainless steel plates						
		Flow rate	m³/h	1.7	2.1	2.4	2.8		
	Circulation pump	Brand	Shinwoo						
		Static pressure ²	kPa	57	50	36	20		
	Water connections	Type	Threaded						
		Dimension	Inch	1" F BSP					
	Operating pressure Min/Max			0.5/2.5					
Expansion vessel	Volume	L	2	3					
	Pre-load	bar	1						
Electrical data	Power supply	Ph/V/Hz	1ph-230V-50Hz						
	Maximum current	Heating	A	25.00	29.00	30.00	30.00		
		Cooling	A	17.50	17.00	21.00	23.00		
Power cable (recommended)	Type	3x6 mm²							
Product specifications	Fan	Type	DC Inverter x 1						
		Air flow	m³/h	5800	5015				
	Sound power level			68					
	Sound pressure level	Heating	dB(A)	56				58	59
		Cooling	dB(A)	54				55	56
	Dimensions	WxDxH	mm	1206x445x878					
Weight	Net	kg	114	132					
Control (supplied)	Wired remote control								

1. Refrigerant leakage contributes to climate change. Refrigerants with a lower global warming potential (GWP) contribute less to global warming when released into the atmosphere than those with a higher GWP. This appliance contains a refrigerant with a GWP of 675. Therefore, if 1 kg of this refrigerant were released into the atmosphere, the impact on global warming would be 675 times greater than 1 kg of CO2, over a period of 100 years. Under no circumstances should the user attempt to intervene on the refrigerant circuit or disassemble the product. If necessary, always contact qualified personnel. 2. Values net of exchanger pressure drops.

GENERAL NOTE:

The above data refers to the following standards: EN 14511:2018; EN 14825:2019; EN50564:2011; EN12102-1:2018; EN12102-2:2019; (EU)No:811:2013; (EU)No:813:2013; OJ 2014/C 207/02:2014.

OUTDOOR UNITS



MCWSGS 1002 - 1202 - 1402 - 1602 Z
3-Phase

ENERGY CLASS

A+++

In heating mode with **35°C** di delivery water temperature.

A+++

In heating mode with **55°C** delivery water temperature.
12.00-15.70 kW models

A++

In heating mode with **55°C** delivery water temperature.
10.20 kW model

Model				MCWSGS 1002 Z	MCWSGS 1202 Z	MCWSGS 1402 Z	MCWSGS 1602 Z
Heating	Rated power	A7//W35	kW	10.20	12.00	14.20	15.70
	Electrical absorption		2.06	2.49	3.09	3.57	
	Performance coefficient		COP	4.95	4.82	4.60	4.40
	Rated power	A7//W45	kW	10.20	13.00	14.20	16.20
	Electrical absorption		2.60	3.45	3.84	4.49	
	Performance coefficient		COP	3.92	3.77	3.70	3.61
Cooling	Rated power	A35//W18	kW	10.20	12.00	13.90	15.40
	Electrical absorption		2.13	2.61	3.32	4.05	
	Energy efficiency		EER	4.79	4.60	4.19	3.80
	Rated power	A35//W7	kW	9.10	11.10	13.30	13.80
	Electrical absorption		2.80	3.58	4.75	5.09	
	Energy efficiency		EER	3.25	3.10	2.80	2.71
Seasonal heating data	Prated @ -10°C	35/55	kW	9/10	12/12	13/13	13/14
	Seasonal performance coefficient		SCOP	4.80/3.58	4.58/3.83	4.55/3.83	4.55/3.83
	Seasonal energy efficiency (ηs)		%	189/140	180/150	179/150	179/150
	Energy efficiency class		-	A+++/A++	A+++/A+++	A+++/A+++	A+++/A+++
	Annual energy consumption		kWh/y	4069/5907	5517/6391	5927/7176	5927/7404
Operating range	Outdoor air temperature	Heating	-25~-35				
		Cooling	-15~-48				
		DHW	-25~-45				
	Delivery water temperature	Heating	20~65				
Cooling		5~25					
Refrigerant circuit data	Refrigerant ¹	Type (GWP)	R32 (675)				
	Quantity (tons CO2)	kg (t)	1.6 (1.080)	2.2 (1.485)			
	Control system	Electronic expansion valve					
	Compressor	Type	Rotary - DC Inverter				
Hydraulic data	Heat exchanger	Type	With brazed stainless steel plates				
		Flow rate	m³/h	1.7	2.1	2.4	2.8
	Circulation pump	Brand	Shinwoo				
		Static pressure ²	kPa	57	50	36	20
	Water connections	Type	Threaded				
		Dimension	Inch	1" F BSP			
	Operating pressure Min/Max			0.5/2.5			
Expansion vessel	Volume	L	3				
	Pre-load	bar	1				
Electrical data	Power supply	Ph/V/Hz	3ph-400V-50Hz				
	Maximum current	Heating	A	9.00	11.50	12.00	12.50
		Cooling	A	6.00	5.00	8.00	8.50
Power cable (recommended)	Type	5x2.5 mm²					
Product specifications	Fan	Type	DC Inverter x 1				
		Air flow	m³/h	5800	5015		
	Sound power level			68			
	Sound pressure level	Heating	dB(A)	56	58		59
		Cooling	dB(A)	54	55		56
	Dimensions	WxDxH	mm	1206x445x878			
Weight	Net	kg	124	138			
Control (supplied)	Wired remote control						



1. Refrigerant leakage contributes to climate change. Refrigerants with a lower global warming potential (GWP) contribute less to global warming when released into the atmosphere than those with a higher GWP. This appliance contains a refrigerant with a GWP of 675. Therefore, if 1 kg of this refrigerant were released into the atmosphere, the impact on global warming would be 675 times greater than 1 kg of CO2, over a period of 100 years. Under no circumstances should the user attempt to intervene on the refrigerant circuit or disassemble the product. If necessary, always contact qualified personnel. 2. Values net of exchanger pressure drops.

GENERAL NOTE:

The above data refers to the following standards: EN 14511:2018; EN 14825:2019; EN50564:2011; EN12102-1:2018; EN12102-2:2019; (EU)No:811:2013; (EU)No:813:2013; OJ 2014/C 207/02:2014.

MODULAR MONOBLOC R32

Air-to-water heat pump

		kW	60	100	130
<p>MCWSGS-ZP Big Chiller Pump included Cooling/Heating Modularity up to 3 units of the same size</p>	<p>NEW</p> 		✓		
<p>MCWSGS-ZP Big Chiller Pump included Cooling/Heating Modularity up to 3 units of the same size</p>	<p>NEW</p> 			✓	✓

MONOBLOC MODULAR AIR-TO-WATER HEAT PUMP R32

The new range of modular Full DC Inverter heat pumps is ideal for cooling and heating residential and commercial buildings.

Available in three sizes - 60, 100 and 130 kW cooling capacity - modularity is one of its key strengths: up to three modules **of the same size** can be combined for a maximum of 390 kW cooling capacity.

Circulation pump included on all models.

High power
in combination

60-100-130 kW 390 kW

Outdoor units' capacities

Maximum capacity
combining 3 units
of 130 kW

Energy
efficiency

A+++

In heating mode with
35 C delivery water
temperature.

R32

30% less charge
than R410A gas.

Modbus

The system is equipped
with Modbus protocol
as standard.



Control consumption with the "Energy saving" mode

The unit is able to estimate the thermal load of the building based on the outside air temperature, consequently modifying the flow water temperature set in order to reduce energy consumption.

OUTLET WATER TEMPERATURE

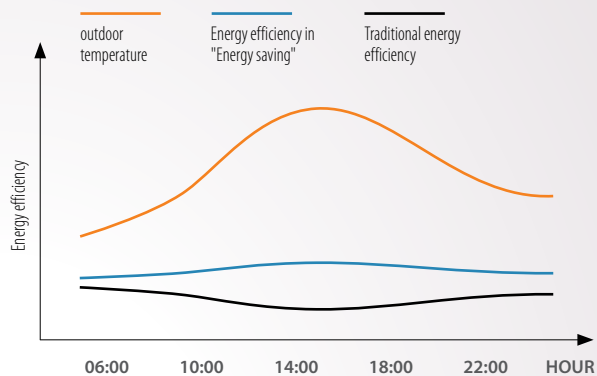
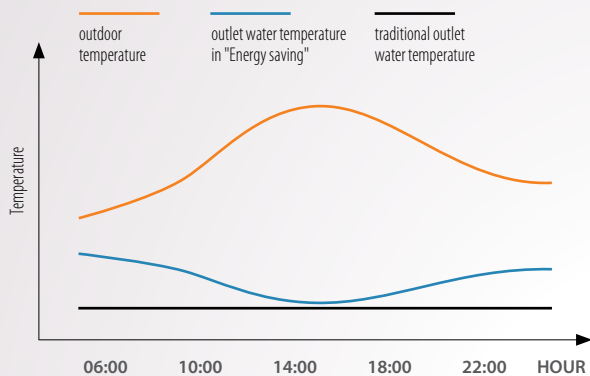

Wide operating range

COOLING MODE

❄️ from -15°C to 52°C

🔥 from 5°C to 20°C (delivery temp.)

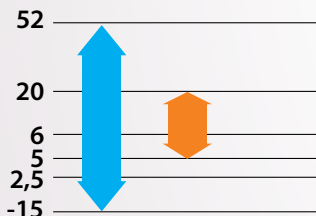

❄️ Outdoor air temperature

🔥 Delivery water temperature

HEATING MODE

❄️ from -20°C to 40°C

🔥 from 35°C to 50°C (delivery temp.)

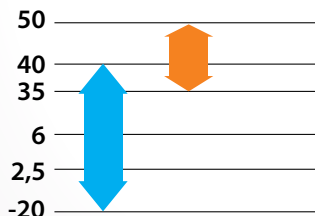

-15°C

Minimum outside temperature in cooling mode

52°C

Maximum outside temperature in cooling mode

-20°C

Minimum outside temperature in heating mode

40°C

Maximum outside temperature in heating mode



Very quiet operation

- > Wide plastic fan blades
- > «Quiet mode» function
- > Compressor sound insulation
- > Special design of the fan area

High-efficiency plate heat exchanger

New stainless-steel plate heat exchanger that maximises heat transfer efficiency, reducing footprint and weight thanks to its ultra-compact dimensions.



Extended operating life through load balancing

Smart Control distributes compressor operating hours evenly, preventing overuse of individual compressors and increasing system reliability and service life.

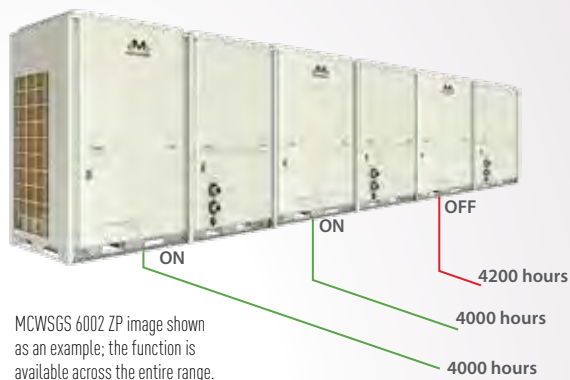

Full DC Inverter as standard

Compressor, fan motor and circulation pump are all DC Inverter components: this ensures maximum operating efficiency and controlled energy consumption.

Winter comfort with staggered defrost

Modular units perform defrost in turns rather than simultaneously, reducing fluctuations in outlet water temperature and, as a result, improving indoor comfort.

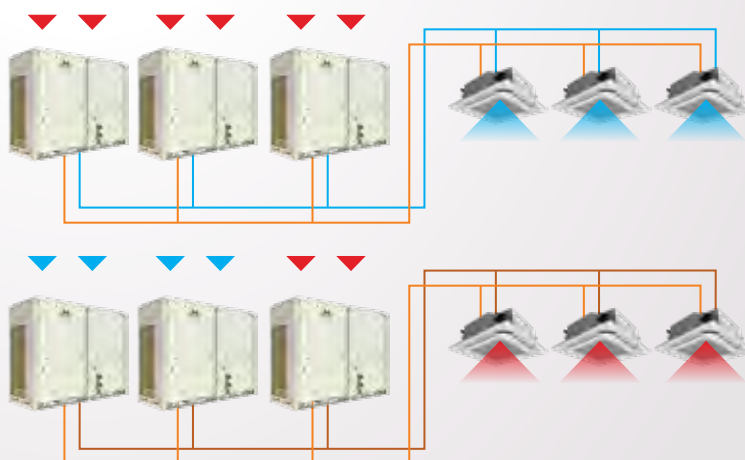

MCWSGS 6002 ZP image shown as an example; the function is available across the entire range.

Multiple anti-freeze protections

By monitoring temperature, pressure and water flow rate, the system prevents plate heat exchanger freezing and always guarantees the best heat transfer efficiency.

Operational continuity with free master unit

Each unit can be a master. In the event of a malfunction of a master unit, communication between the units of the same system is timely. A possible problem on one unit does not affect the normal functioning of the others, ensuring operational continuity.



Centralized control up to 3 units

The wired remote control allows you to control up to 3 units.

- It is equipped with a 4.3-inch backlit LCD touch screen display.
- Allows the display of parameters and operating status in real time.
- It features anti-corrosion structure.
- Touch screen, allows easy and quick operations.
- It can show up to 10 error codes on the same page.



Remote on/off thanks to the clean contact

The unit (or group of units) can be put into standby/ON by means of a clean external contact.

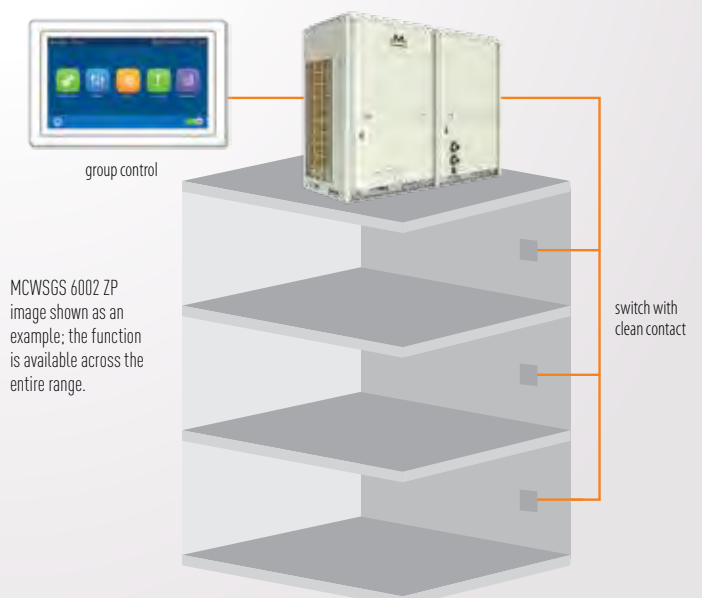

OUTDOOR UNITS



MCWSGS 6002 ZP



MCWSGS 10002 ZP
MCWSGS 13002 ZP

ENERGY CLASS

A++

In heating mode with 35°C delivery water temperature.

Model				MCWSGS 6002 ZP	MCWSGS 10002 ZP	MCWSGS 13002 ZP	
Heating	Rated power	A7//W35	kW	62.00	100.00	126.00	
	Electrical absorption			15.97	25.38	32.72	
	Performance coefficient			3.88	3.94	3.85	
	Rated power	A7//W45	kW	65.00	105.00	131.00	
	Electrical absorption			19.70	30.20	41.58	
	Performance coefficient			3.30	3.48	3.15	
Cooling	Rated power	A35//W7	kW	60.00	100.00	130.00	
	Electrical absorption			21.13	31.95	44.07	
	Energy efficiency			2.84	3.13	2.95	
	Rated power	A35//W18	kW	64.00	130.00	150.00	
	Electrical absorption			18.00	33.00	39.00	
	Energy efficiency			3.56	3.94	3.85	
Seasonal heating data	Prated @ -10°C	W35	kW	52.00	74.00	90.00	
	Seasonal performance coefficient			SCOP	4.01	4.12	4.17
	Seasonal energy efficiency (ηs)			%	157.50	161.90	163.90
	Energy efficiency class			-	A++	A++	A++
	Annual energy consumption			kWh/y	26825	37471	44570
Operating range	Outdoor air temperature	Heating	°C	-20~40			
		Cooling		-15~52			
	Delivery water temperature	Heating	°C	35~50			
		Cooling		5~20			
Refrigerant circuit data	Refrigerant1 type (GWP)				R32 (675)		
	Refrigerant1 - Pre-charge (tonsCO2)	kg (t)	10.7 (7.223)	11.5 (7.763)	11.5 (7.763)		
	Refrigerant1 - Charge to be added on site (tons CO2)	kg (t)	-	8.5 (5.738)	8.5 (5.738)		
	Control system				Electronic expansion valve		
	Compressor	Type	Rotary DC Inverter x 2		Scroll DC Inverter x 2	Scroll DC Inverter x 2	
Hydraulic data	Heat exchanger	Type				Plate	
		Flow rate	m³/h	10.30	17.20	22.36	
	Circulation pump (included)	Type				Inverter	
	Water connections	Type				Threaded	
		Dimension	Inch	G2" M (DN50)	2-1/2" (DN65)	2-1/2" (DN65)	
	Operating pressure Min/Max			bar	2/6	2/6	
Expansion vessel (included)	Volume	L	12	24	24		
Electrical data	Power supply	Ph-V-Hz		3-380~415V-50Hz			
	Maximum current	A		52.00	94.00	103.00	
	Power cable (recommended)	Type		5x16 mm²	5x25 mm²	5x35 mm²	
Product specifications	Fan	Type	q.ty			DC Inverter x 2	
		Air flow	m³/h	12000 x 2	22500 x 2	22500 x 2	
	Sound pressure level			dB(A)	68	69	72
	Sound power level			dB(A)	70	70	72
	Dimensions	WxDxH	mm	2200x937x1675	2235x1283x2355	2235x1283x2355	
	Weight	Net	kg	609	1016	1016	
	Controls	Wired control (NOT included)		DMWZ-CWG-BIG			
		Modbus	Integrated				

GENERAL NOTE: The above data refers to the following standards: EN 14511:2018; EN 14825:2019; EN50564:2011; EN12102-1:2018; EN12102-2:2019; (EU)No:811:2013; (EU)No:813:2013; OJ 2014/C 207/02:2014

1. Refrigerant leakage contributes to climate change. Refrigerants with a lower global warming potential (GWP) contribute less to global warming when released into the atmosphere than those with a higher GWP. This appliance contains a refrigerant with a GWP of 675. Therefore, if 1 kg of this refrigerant were released into the atmosphere, the impact on global warming would be 675 times greater than 1 kg of CO2, over a period of 100 years. Under no circumstances should the user attempt to intervene on the refrigerant circuit or disassemble the product. If necessary, always contact qualified personnel. 2. Values net of exchanger pressure drops.



SPLIT R32 WITH HYDROMODULE AND WITH HYDROMODULE AND BUILT-IN TANK

Air-to-water heat pump

OUTDOOR UNITS



MCENG5 600 Z



MCENG5 800~1200 Z
MCESGS 1400~1600 Z

INDOOR UNIT HYDROMODULE



MHNGS 400~1600 Z
MHSGS 1200~1600 Z











INDOOR UNIT HYDROMODULE AND BUILT-IN TANK



MHANGS 401~1601 Z
MHASGS 1201~1601 Z











SPLIT R32 WITH HYDROMODULE

Air-to-water heat pump

kW	6	8	10	12	14	15.5
	 MCENG 600 Z 1-Phase	 MCENG 800 Z 1-Phase	 MCENG 1000 Z 1-Phase	 MCENG 1200 Z 1-Phase	 MCESG 1400 Z 3-Phase	 MCESG 1600 Z 3-Phase
 MHNGS 400-600 Z	✓					
 MHNGS 800-1000 Z		✓	✓			
 MHNGS 1200-1600 Z				✓		
 MHSGS 1200-1600 Z					✓	✓

SPLIT R32 WITH HYDROMODULE AND BUILT-IN TANK

Air-to-water heat pump

	kW	6	8	10	12	14	15.5
		 MCENG 600 Z 1-Phase	 MCENG 800 Z 1-Phase	 MCENG 1000 Z 1-Phase	 MCENG 1200 Z 1-Phase	 MCESG 1400 Z 3-Phase	 MCESG 1600 Z 3-Phase
 MHANGS 401-601 Z		✓					
 MHANGS 801-1001 Z			✓	✓			
 MHANGS 1201-1601 Z					✓		
 MHASGS 1201-1601 Z						✓	✓

SPLIT R32 AIR-TO-WATER HEAT PUMP

WITH HYDROMODULE AND BUILT-IN TANK

Split R32 is the new range of air-to-water heat pumps with the latest-generation DC Inverter technology, ideal for cooling, heating and DHW production.

The split system is available in two configurations:
with hydromodule, or with hydromodule featuring an integrated tank.

The range includes single-phase versions from 6 to 12 kW and three-phase versions from 14 to 15.5 kW of heating output, achieving COP up to 5 in heating mode.

Energy efficiency

A+++

In heating mode with **35°C** delivery water temperature.

A++

In heating mode with **55°C** delivery water temperature.

R32

30% less charge than R410A gas.

Design flexibility

6~15.5 kW

Capacities

Features of the Split R32 heat pump with hydromodule and built-in tank

- > DC Brushless Axial fans are designed for aerodynamic optimization, guaranteeing low noise levels, but high efficiency and large air flow.
- > It is equipped with an electric resistance on the base, to prevent ice formation during winter operation.
- > The outdoor unit is equipped with an electronic expansion valve.
- > The system is equipped with Modbus protocol as standard: control via WiFi is possible.

Connectivity and remote control

The unit allows connection to a BMS supervision system using the Modbus protocol as standard.

By installing the MULTIWARM Ewpe Smart APP application on your smartphone, you will be able to remotely control the most significant parameters of the heat pump via integrated WiFi.

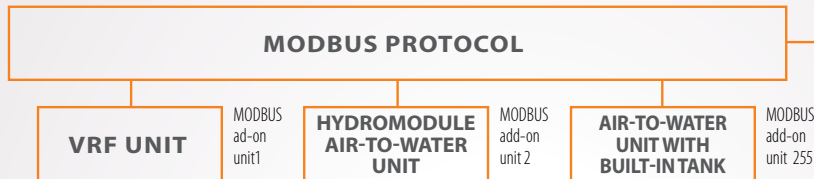
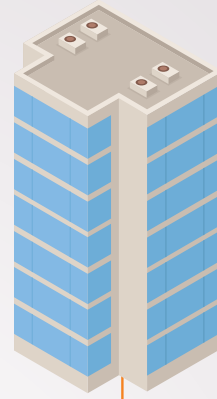

Dual stage compressor with vapor injection

Under low outside temperature conditions, the dual-stage compressor with vapor injection reduces heat capacity losses and has higher energy efficiency than the conventional compressor.

Under the same conditions, high compressor discharge temperatures and other problems can be completely avoided and the compressor reliability is significantly higher.

Double-stage compression, double-stage lamination and steam injection increase the outlet water temperature and improve control accuracy.

Golden fin anti-corrosion protective treatment

The heat exchanger coils are subjected to a special protective anti-corrosion treatment "Golden Fin".

The heat exchanger fins, made of aluminum-manganese, are coated with a special layer of epoxy resin, which gives them the typical golden color, and with an additional hydrophilic layer.

This special treatment is able to protect the exchanger from rust and corrosion in areas with air with a high salt concentration, typical of marine areas.

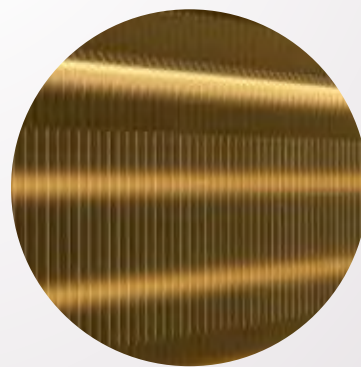

Wide operating range

The outlet water temperature range is from 20°C to 60°C: this allows use with radiant floors, hydronic terminals and medium temperature radiators.

COOLING MODE

from 10° C to 48° C

from 7° C to 25° C
(delivery temp.)

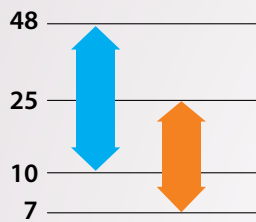

Outdoor air temperature

Delivery water temperature

DHW PRODUCTION

from -25° C to 45° C

from 40° C to 80° C
(tank temp.)

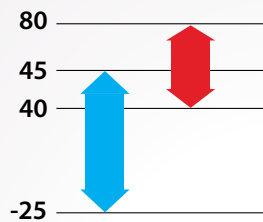

DHW tank temperature

HEATING MODE

from -25° C to 35° C

from 20° C to 60° C
(delivery temp.)

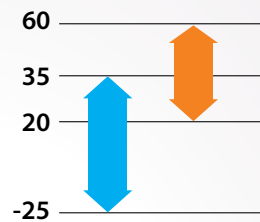

48°C

Maximum outside temperature in cooling mode

-25°C

Minimum outside temperature in heating mode



Touch screen control panel

The control panel, supplied as standard and integrated into the indoor unit, allows you to:

- > define the operating mode of the heat pump and its priorities (heating, cooling, production of domestic hot water);
- > set all the main operating parameters (set point, hysteresis, etc.);
- > activate external or internal systems for integration or replacement of the heating and domestic hot water production unit;
- > manage the unit commissioning activity;
- > view the status of the operating parameters of the main components of the heat pump;
- > manage the unit remotely by connecting to a Modbus network or via the Wi-Fi integrated into the control panel.

Specific auxiliary functions are also available in the control panel, including:

- > automatic management of the fluid delivery temperature based on the external temperature (climate curve);
- > weekly and time-band operation programming;
- > activation of silent operation;
- > emergency management in case of unit malfunction;
- > programmable activation of the anti-legionella cycle via electric resistance in the tank;
- > automatic activation of frost protection.

SPLIT MODEL WITH HYDROMODULE - SYSTEM DIAGRAM

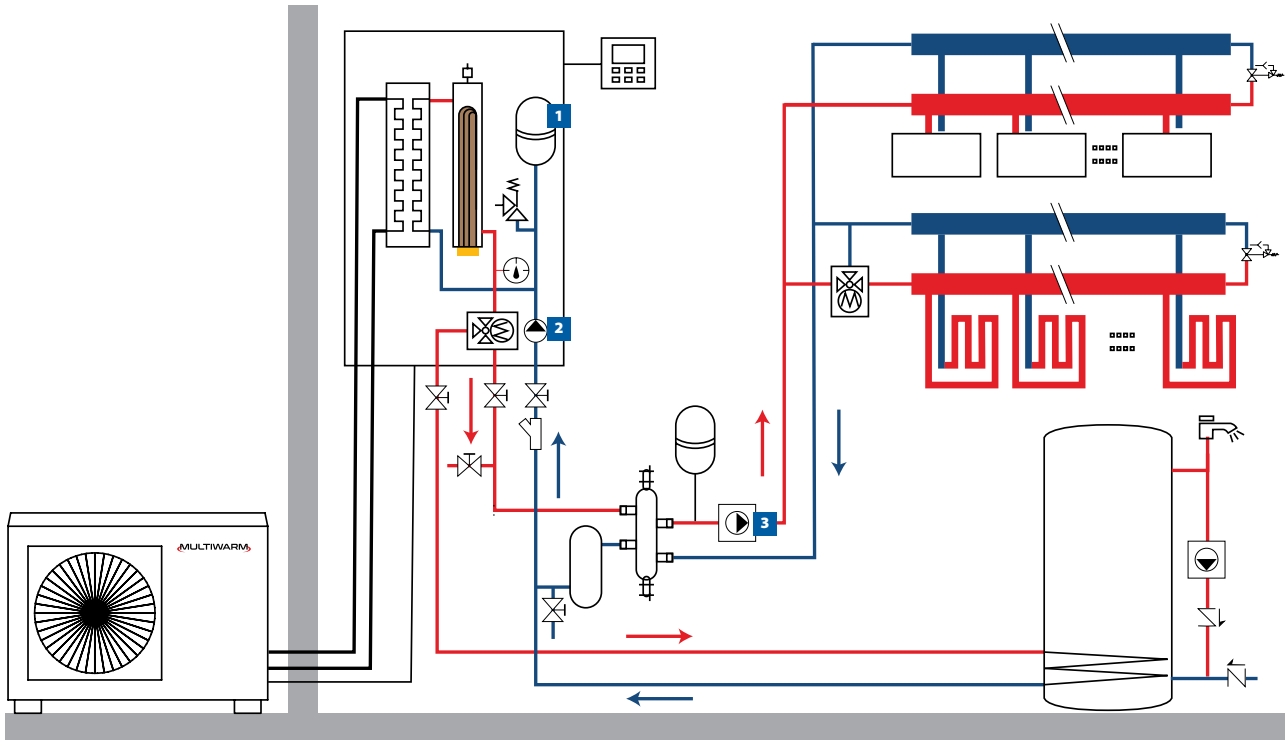

NOTE: 1. Expansion vessel referred to the system circuit. Check that what is included in the unit is sufficient for the purpose. 2. Primary circulator on the system side. 3. Secondary circulator on the system side.



DMG-HP-Z control

Group control, connect up to four R32 Monobloc or Split Series units, even combined together. Main functions:

- > Silent mode;
- > fast hot water;
- > Holiday mode;
- > Climate;
- > Child lock;
- > anti-legionella programming via electrical resistance in the tank;
- > Error reset;
- > Weekly timer.



SPLIT MODEL WITH HYDROMODULE

MCENGS 600 Z



MCENGS 800~1200 Z
MCESGS 1400~1600 Z



MHNGS 400-1600 Z
MHSGS 1200~1600 Z



ENERGY CLASS

A+++

In heating mode with 35°C delivery water temperature.

A++

In heating mode with 55°C delivery water temperature.

Outdoor unit model				MCENGS 600 Z	MCENGS 800 Z	MCENGS 1000 Z	MCENGS 1200 Z	MCESGS 1400 Z	MCESGS 1600 Z	
Heating	Rated power	A7//W35	kW	6.00	8.00	10.00	12.00	14.00	15.50	
	Electrical absorption			1.20	1.61	2.10	2.40	2.98	3.44	
	Performance coefficient			5.00	4.97	4.76	5.00	4.70	4.51	
	Rated power	A7//W45	kW	5.80	8.00	9.85	12.40	14.44	16.13	
	Electrical absorption			1.52	2.07	2.69	3.29	3.63	4.16	
	Performance coefficient			3.82	3.86	3.66	3.77	3.98	3.88	
Cooling	Rated power	A35//W18	kW	5.80	7.70	9.35	11.00	12.60	13.00	
	Electrical absorption			1.13	1.72	2.36	2.50	3.41	3.6	
	Energy efficiency			5.15	4.48	3.96	4.40	3.70	3.61	
	Rated power	A35//W7	kW	4.00	7.15	7.60	10.59	11.24	11.52	
	Electrical absorption			1.16	2.49	2.77	3.79	4.13	4.38	
	Energy efficiency			3.45	2.87	2.74	2.79	2.72	2.63	
Seasonal heating data	Theoretical load (Pdesignh) @ -10°C	35/55	kW	6/5	7/7	9/8	11/11	12/13	13/13	
	Seasonal energy efficiency (ηs)			%	178.7/127.4	181/129	181/127	182/126	175/131	175/131
	Energy efficiency class			-	A+++/A++	A+++/A++	A+++/A++	A+++/A++	A+++/A++	A+++/A++
	Annual energy consumption			kWh/y	2729/3169	3149/4371	4038/5091	4967/6985	5552/7958	6027/7958
Operating range	Outdoor air temperature	Heating	°C	-25~35						
		Cooling		10~48						
		DHW		-25~45						
Refrigerant circuit data	Refrigerant type (GWP)	R32 (675)								
	Qty of pre-charge (tons CO2)	kg (t)	1.1 (0.743)	1.84 (1.242)	1.84 (1.242)			1.84 (1.242)		
	Piping diameter Liquid/Gas	mm (inch)	6.35(1/4") / 12.74(1/2")		6.35(1/4") / 12.74(1/2")		6.35(1/4") / 15.88(5/8")			
	Max splitting length	m	20	15	15	15	15	15		
	Max height difference O.U.-I.U. / I.U.-O.U.	m	15	15	15	15	15	15		
	Splitting length without additional charge	m	10	15	15	15	15	15		
	Additional charge	g/m	16	0	0	0	0	0		
	Refrigerant control system	Electronic expansion valve								
	Compressor	Type	Rotary - DC Inverter							
	Electrical data	Power supply	Ph-V-Hz	1ph-230V-50Hz				3ph-400V-50Hz		
Maximum current		Heating	A	10.00	13.50	15.00	17.80	8.00	8.50	
		Cooling	A	11.00	20.00	22.00	25.60	11.50	11.50	
Power cable (recommended)	Type	3x2.5 mm ²		3x4 mm ²			5x2.5 mm ²			
Product specifications	Ventilatore	Tipo	DC Inverter		DC Inverter			DC Inverter		
	Sound power level	Portata aria	m ³ /h	3200	3300	3300	5015	5015	5015	
		dB(A)	62	67	68	68	68	68		
	Sound pressure level	dB(A)	52	55	55	57	58	58		
	Dimensions	WxDxH	mm	975x396x702	982x427x787	982x427x787	940x460x820	940x460x820	940x460x820	
Weight	Net	kg	55	82	82	104	110	110		
Indoor unit model				MHNGS 400-600 Z	MHNGS 800-1000 Z	MHNGS 1200-1600 Z	MHSGS 1200-1600 Z			
Operating range	Delivery water temperature	Heating	°C	20~60		20~60		20~60		
		Cooling		7~25		7~25		7~25		
		DHW temperature (tank)		40~80		40~80		40~80		
Hydraulic data	Water/freon heat exchanger	Type	Braze plate							
	Circulation pump	Brand	Shinhoo							
	Water connections	Type	Threaded							
		Dimension	Inch	1" M BSP	1" M BSP	1" M BSP	1" M BSP	1" M BSP		
	Operating pressure	Min/Max	bar	0.5/2.5	0.5/2.5	0.5/2.5	0.5/2.5			
	Expansion vessel	Volume	L	10	10	10	10			
Pre-load		bar	1	1	1	1				
Electrical data	Power supply	Ph-V-Hz	1ph-230V-50Hz				3ph-400V-50Hz			
	Electrical integration	kW	3.00	6.00	6.00	6.00				
	Electrical absorption	Max	kW	3.10	6.10	6.10	6.1			
Product specifications	Power cable (recommended)	Type	3x2.5 mm ²		3x6 mm ²			5x4 mm ²		
	Sound power level	dB(A)	42	42	42	42				
	Sound pressure level	dB(A)	29	29	29	29				
	Dimensions	WxDxH	mm	460x318x860	460x318x860	460x318x860	460x318x860			
	Weight	Net	kg	58	58	58	60			
Control (supplied)			On-board machine control							
Integrated remote control			Wifi. Modbus							

GENERAL NOTE: The above data refers to the following standards: EN 14511:2018; EN 14825:2019; EN50564:2011; EN12102-1:2018; EN12102-2:2019; (EU)No:811:2013; (EU)No:813:2013; OJ 2014/C 207/02:2014.

SPLIT MODEL WITH HYDROMODULE AND BUILT-IN TANK SYSTEM DIAGRAM

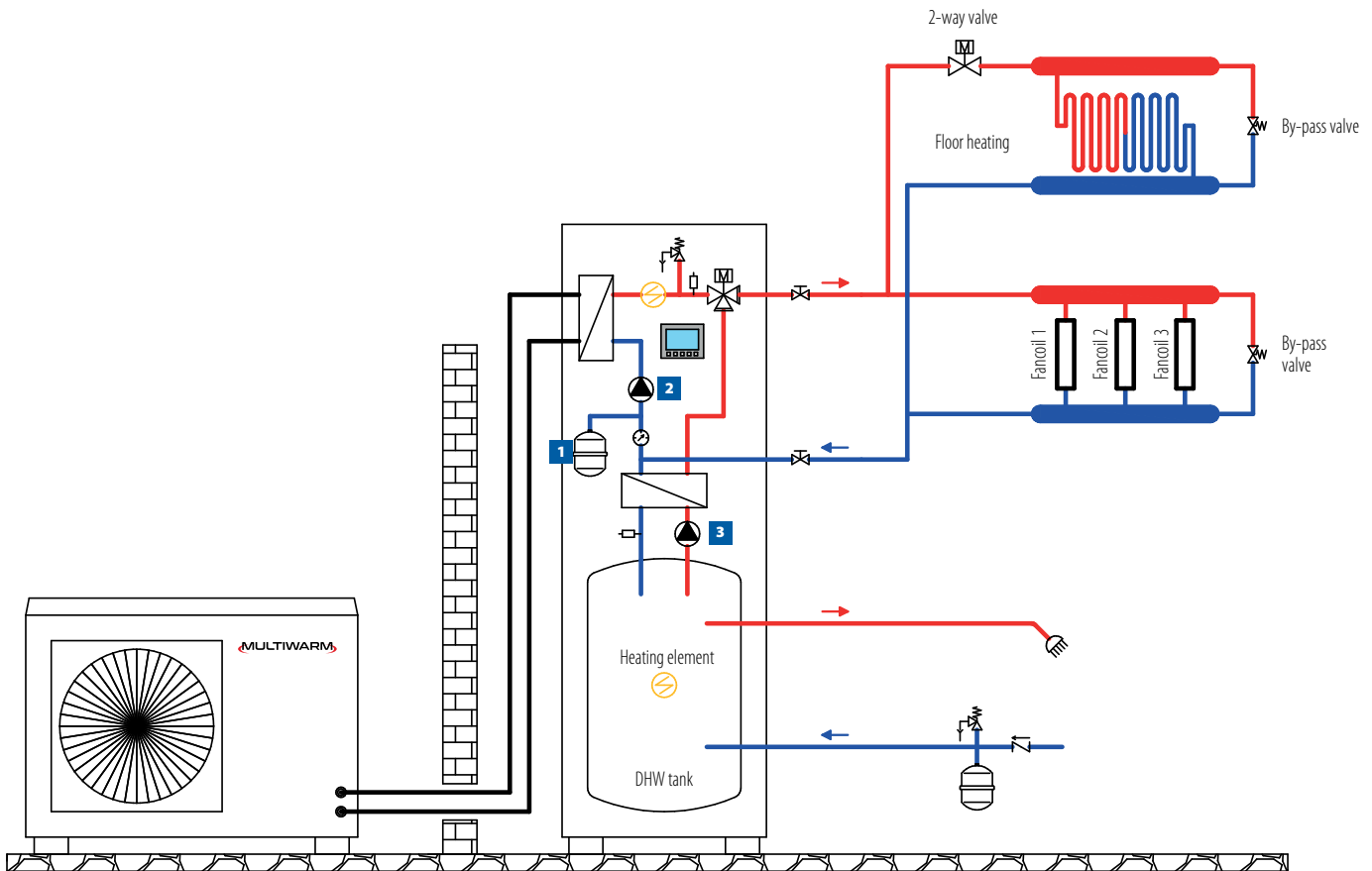

NOTE: 1. Vaso d'espansione riferito al circuito d'impianto. Verificare che quanto incluso nell'unità sia sufficiente allo scopo. 2. Circolatore lato impianto. 3. Circolatore lato acqua sanitaria.



DMG-HP-Z control

Group control, connect up to four R32 Monobloc or Split Series units, even combined together. Main functions:

- > Silent mode;
- > fast hot water;
- > Holiday mode;
- > Climate;
- > Child lock;
- > anti-legionella programming via electrical resistance in the tank;
- > Error reset;
- > Weekly timer.



SPLIT MODEL WITH HYDROMODULE AND BUILT-IN TANK

MCENGS 600 Z



MCENGS 800~1200 Z
MCESGS 1400~1600 Z



MHANGS
401-1601 Z
MHASGS
1201-1601 Z

ENERGY CLASS

A+++

In heating mode with **35°C** delivery water temperature.

A++

In heating mode with **55°C** delivery water temperature.

Outdoor unit model				MCENGS 600 Z	MCENGS 800 Z	MCENGS 1000 Z	MCENGS 1200 Z	MCESGS 1400 Z	MCESGS 1600 Z		
Heating	Rated power	A7//W35	kW	6.00	8.00	10.00	12.00	14.00	15.50		
	Electrical absorption			1.20	1.61	2.10	2.40	2.98	3.44		
	Performance coefficient		A7//W45	COP	5.00	4.97	4.76	5.00	4.70	4.51	
	Rated power				5.80	8.00	9.85	12.40	14.44	16.13	
Cooling	Electrical absorption	A35//W18	kW	1.52	2.07	2.69	3.29	3.63	4.16		
	Performance coefficient			3.82	3.86	3.66	3.77	3.98	3.88		
	Rated power		A35//W18	kW	5.80	7.70	9.35	11.00	12.60	13.00	
	Electrical absorption				1.13	1.72	2.36	2.50	3.41	3.60	
	Energy efficiency		A35//W7	EER	5.13	4.48	3.96	4.40	3.70	3.61	
	Rated power				4.00	7.15	7.60	10.59	11.24	11.52	
Seasonal heating data	Electrical absorption	35/55	kW	1.16	2.49	2.77	3.79	4.13	4.38		
	Energy efficiency			3.45	2.87	2.74	2.79	2.72	2.63		
	Theoretical load (Pdesignh) @ -10°C		6/5	7/7	9/8	11/11	12/13	13/13			
	Seasonal energy efficiency (ηs)		%	182/128	181/129	181/127	182/126	175/132	175/132		
Operating range	Outdoor air temperature	Heating	°C	-25~35							
		Cooling		10~48							
Refrigerant circuit data	Refrigerant type (GWP)				R32 (675)						
	Q.ty of pre-charge (tons CO2)	kg (t)	1.1 (0.743)		1.84 (1.242)		1.84 (1.242)		1.84 (1.242)		
	Piping diameter Liquid/Gas	mm (inch)	6.35(1/4") / 12.74(1/2")			6.35(1/4") / 12.74(1/2")			6.35(1/4") / 15.88(5/8")		
	Max splitting length	m	20	25	25	15	15	15	15		
	Max height difference O.U.-I.U. / I.U.-O.U.	m	15	15	15	15	15	15	15		
	Splitting length without additional charge	m	10	25	25	15	15	15	15		
	Additional charge	g/m	16	0	0	0	0	0	0		
	Refrigerant control system	Electronic expansion valve									
	Compressor	Rotativo bistadio - DC Inverter									
	Electrical data	Power supply	Ph-V-Hz	1ph-230V-50Hz				3ph-400V-50Hz			
Maximum current		Heating	A	10.00	13.50	15.00	17.80	8.00	8.50		
		Cooling	11.00	20.00	22.00	25.60	11.50	11.50			
Power cable (recommended)	Ttype	3x2.5 mm ²			3x4 mm ²			5x2.5 mm ²			
Product specifications	Fan	Type	DC Inverter			DC Inverter			DC Inverter		
	Sound power level	q.ty	m ³ /h	3200	3300	3300	5015	5015	5015		
		Air flow	dB(A)	62	67	68	68	68	68		
	Sound pressure level	dB(A)	52	55	55	57	58	58			
Dimensions	WxDxH	mm	975x396x702	982x427x787	982x427x787	940x460x820	940x460x820	940x460x820			
Weight	Net	kg	55	82	82	104	110	110			
Indoor unit model				MHANGS 401-601 Z	MHANGS 801-1001 Z	MHANGS 1201-1601 Z	MHASGS 1201-1601 Z				
Operating range	Delivery water temperature	Heating	°C	20~60		20~60		20~60			
		Cooling		7~25		7~25		7~25			
	DHW temperature (tank)	°C	40~80		40~80		40~80				
Hydraulic data	DHW tank capacity	L	190		190		190				
	Water/freon heat exchanger	Type	Braze plate								
	Circulation pump	Brand	Shinhoo								
	Water connections	Type	Threaded								
		Dimension	Inch	1" M BSP		1" M BSP		1" M BSP			
	Operating pressure	Min/Max	bar	0.5/2.5		0.5/2.5		0.5/2.5			
Expansion vessel	Volume	L	10		10		10				
	Pre-load	bar	1		1		1				
Electrical data	Power supply	Ph-V-Hz	1ph-230V-50Hz				3ph-400V-50Hz				
	Electrical integration	Heating	kW	3.00	6.00	6.00	6.00	6.00			
		Serbatatoio ACS		3.00	3.00	3.00	3.00				
	Electrical absorption	Max	kW	3.175	6.10	6.10	6.10	6.1			
Power cable (recommended)	Type	3x4 mm ²	3x6 mm ²			3x6 mm ²					
Product specifications	Sound power level	dB(A)	47		47		47				
	Sound pressure level	dB(A)	29		29		29				
	Dimensions	WxDxH	mm	600x650x1800		600x650x1800		600x650x1800			
	Weight	Net	kg	195		195		195			
Control (supplied)				On-board machine control							
Integrated remote control				Wifi. Modbus							

GENERAL NOTE: The above data refers to the following standards: EN 14511:2018; EN 14825:2019; EN50564:2011; EN12102-1:2018; EN12102-2:2019; (EU)No:811:2013; (EU)No:813:2013; OJ 2014/C 207/02:2014.

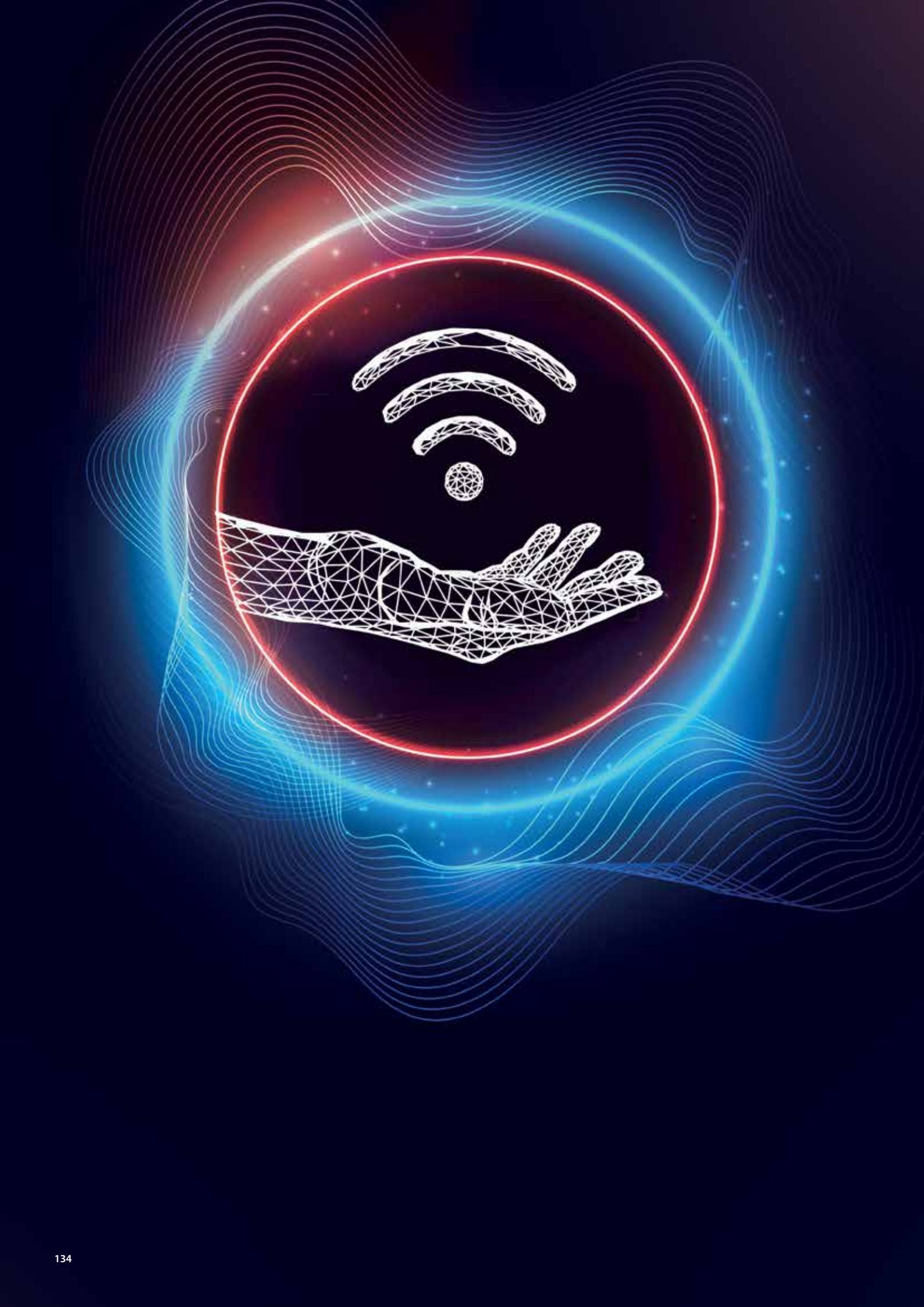

CONTROLS

FOR RESIDENTIAL & LIGHT COMMERCIAL MONOSPLIT/MULTISPLIT R32

- 136 STANDARD INDIVIDUAL CONTROLS R32
- 139 INDIVIDUAL CONTROLS R32
- 140 OPTIONAL CONTROLS R32

FOR VRF SYSTEMS MW MINI - MW 2-PIPE - MW 3-PIPE

- 141 VRF SYSTEMS WIFI CONTROLS
- 142 VRF STANDARD INDIVIDUAL CONTROLS
- 143 VRF OPTIONAL INDIVIDUAL CONTROLS
- 145 VRF OPTIONAL CENTRALIZED CONTROLS
- 146 OTHER VRF OPTIONAL CONTROLS

STANDARD INDIVIDUAL CONTROLS **R32**

INFRARED REMOTE CONTROL



Action Remote control included

MONOSPLIT/MULTISPLIT **R32**

FEATURES

- > Temperature setting & display.
- > Clock.
- > 7 fan speed levels.
- > ON/OFF Timer.
- > Air distribution with automatic vertical flaps' swinging.
- > Autorestart: restart after blackout with restoration of the previous state.

FUNCTIONS

- > I-Feel: optimal control of the room temperature based on the temperature detected by the sensor built into the remote control.
- > Sleep: automatic control of room temperature during night hours (3 functions).
- > X-fan: allows you to dry the evaporator to avoid the formation of mold and bacteria (Airpro Plus).
- > Turbo: rapid reaching of room temperature.
- > Light: activation/deactivation of display brightness (Airpro Plus).
- > Quiet: Silent mode
- > Energy saving (Airpro Plus).
- > WiFi.
- > Cold Plasma: ionizer.

MODES

- > Heating.
- > Dehumidification.
- > Automatic.
- > Cooling.
- > Ventilation.



Airpro Plus Remote control included

MULTISPLIT **R32**



Remote control included

MULTISPLIT **R32**
8-way compact cassette

LIGHT COMMERCIAL **R32**
8-way compact cassette (up to 3.50 kW)
8-way big cassette floor/ceiling (up to 7.10 kW)

FEATURES

- > Clock.
- > ON/OFF Timer.
- > 4 fan speed levels + Turbo function.
- > Air distribution with automatic vertical and/or horizontal flaps' swinging.
- > Setting the room temperature and displaying the indoor and outdoor temperature.

FUNCTIONS

- > I-Feel.
- > Sleep.
- > Energy saving (cooling).
- > Absence (heating).
- > Key lock.
- > X-fan: only cooling and dehumidifying.
- > Light: enables/disables display lighting.

MODES

- > Heating.
- > Cooling.
- > Dehumidification.
- > Ventilation.
- > Automatic.

STANDARD INDIVIDUAL CONTROLS **R32**

INFRARED REMOTE CONTROL



Remote control included
MULTISPLIT **R32**
1-way cassette ceiling

FEATURES

- Temperature setting & display.
- Clock.
- ON/OFF Timer.
- 4 fan speed levels: auto, low, medium or high.
- 6 fan speed levels with console remote control: auto, low, medium-low, medium, medium-high or high.
- Air distribution with automatic vertical flaps' swinging.
- Autorestart: restart after blackout with restoration of the previous state.

FUNCTIONS

- I-Feel: optimal control of the room temperature based on the temperature detected by the sensor built into the remote control.
- Sleep: automatic control of room temperature during night hours.
- X-fan: only in cooling and dehumidification.
- Turbo: the unit operates at very high speed to quickly reach the cooling or heating temperature.
- Light: display brightness on/off.
- Quiet: Silent mode.
- Energy saving.
- Key lock.

MODES

- Heating.
- Cooling.
- Dehumidification.
- Ventilation.
- Automatic.



Remote control included
MONOSPLIT **R32**
console



Remote control included
LIGHT COMMERCIAL **R32**
8-way big cassette floor/ceiling (from 10 to 16 kW)

FEATURES

- Temperature setting & display.
- Clock.
- ON/OFF Timer.
- 4 fan speed levels: auto, low, medium or high.
- Dehumidification.
- Ventilation.
- Automatic.

FUNCTIONS

- Follow me: adjusts the room temperature according to that detected by the remote control to obtain maximum comfort.
- Sleep: automatic control of room temperature during night hours.
- Self Clean: allows the evaporator to dry to avoid the formation of mold and bacteria.
- Turbo: the unit operates at very high speed to quickly reach the cooling or heating temperature.
- Led: brightness adjustment.
- Breeze Away: in cooling, ventilation and dehumidification mode, it allows you to avoid a direct air flow.

STANDARD INDIVIDUAL CONTROLS R32

WIRED CONTROL



Wired control

STANDARD (included) for the models
LIGHT COMMERCIAL R32
ducted
(up to 7.10 kW)

FEATURES

- > Temperature setting & display.
- > ON/OFF Timer.
- > 5 fan speed levels + auto.

FUNCTIONS

- > Sleep: automatic control of room temperature during night hours.
- > Turbo: the unit operates at very high speed to quickly reach the cooling or heating temperature.
- > X-fan: after the unit has been turned off, it allows the evaporator to dry to prevent the formation of mold and bacteria.
- > Key lock.

MODES

- > Heating.
- > Cooling.
- > Dehumidification.
- > Ventilation.
- > Automatic.

WIRED CONTROL



DMW-W2-ZA

STANDARD (included) for the models
LIGHT COMMERCIAL R32
ducted
(from 10 to 16 kW)

FEATURES

- > LCD Display.
- > Error codes display.
- > Room temperature display.
- > Weekly Timer.

FUNCTIONS

- > Follow me.
- > Turbo: the unit operates at very high speed to quickly reach the cooling or heating temperature.
- > Auto Restart.
- > ON/OFF Timer.
- > Weekly Timer.

MODES

- > Heating.
- > Cooling.
- > Dehumidification.
- > Ventilation.
- > Automatic.

INDIVIDUAL CONTROLS R32

WIRED CONTROL WITH BUILT-IN WI-FI MODULE



DMW-ZA1-WiFi

Optional for the models
LIGHT COMMERCIAL R32
8-way compact cassette

Up to 7.10 kW:
8-way big cassette
floor/ceiling,
ducted

CARATTERISTICHE

- > Impostazione e visualizzazione della temperatura.
- > Timer ON/OFF.
- > 5 livelli di velocità del ventilatore + auto.

FUNCTIONS

- > Sleep: automatic control of room temperature during night hours.
- > Turbo: the unit operates at very high speed to quickly reach the cooling or heating temperature.
- > X-fan: after the unit has been turned off, it allows the evaporator to dry to prevent the formation of mold and bacteria.
- > Key lock.

MODES

- > Heating.
- > Dehumidification.
- > Automatic.
- > Raffrescamento.
- > Ventilation.

WIRED CONTROL WITH BUILT-IN WI-FI MODULE



DMW-ZAL-LCAC WiFi Wired control

STANDARD (included)
for the models
MULTISPLIT R32
ducted

Optional for the models
MULTISPLIT R32
8-way compact cassette
1-way cassette
ceiling

FEATURES

- > Integrated ambient temperature sensor.
- > 6 levels of fan speed.
- > Error display.
- > ON/OFF Timer.
- > Memory: restart after blackout with restoration of previous state.

FUNCTIONS

- > Sleep: automatic control of room temperature during night hours.
- > Turbo: the unit operates at very high speed to quickly reach the cooling or heating temperature.
- > Quiet: Silent mode.
- > X-fan: it allows the evaporator to dry to prevent the formation of mold and bacteria.
- > Absence (heating only): prevents the room temperature from falling below 8° C.
- > Key lock.

MODES

- > Heating.
- > Dehumidification.
- > Automatic.
- > Cooling.
- > Ventilation.

OPTIONAL CONTROLS R32

WIRED CONTROL



M-RF-CW2-L-G M-RF-CW3-L-G*

Wired control

Optional for the models
MULTISPLIT R32
wall (Airpro Plus & Action)
console
1-way cassette
compact cassette
ceiling

* **Note for M-RF-CW3-L-G:**
Mandatory for 1-way
cassette, compact cassette
and ceiling units if you want
to use the central

CARATTERISTICHE

- > 4 fan speeds: auto, low, medium, or high.
- > Air distribution with automatic vertical and/or horizontal flaps' swinging.
- > Error display.
- > Daily, weekly, or bi-weekly timer.
- > Memory: restart after blackout with restoration of previous state.

FUNCTIONS

- > Sleep: automatic control of room temperature during night hours.
- > Turbo: the unit operates at very high speed to quickly reach the cooling or heating temperature.
- > Quiet: Silent mode.
- > X-Fan: after the unit has been turned off, it allows the evaporator to dry to prevent the formation of mold and bacteria.
- > Absence (heating only): prevents the room temperature from falling below 8° C.
- > Key lock.

MODES

- > Heating.
- > Cooling.
- > Dehumidification.
- > Ventilation.
- > Automatic.

WIRED CONTROL WITH BUILT-IN WIFI MODULE



DMW-WIFI-ZA

Wired control

optional for the models
LIGHT COMMERCIAL R32
ducted 10-16 kW
floor/ceiling 10-16 kW
big cassette 84x84 10-16 kW

FEATURES

- > LCD Display.
- > Error codes display.
- > Room temperature display.
- > Weekly Timer.

FUNCTIONS

- > Follow me.
- > Turbo: the unit operates at very high speed to quickly reach the cooling or heating temperature.
- > Auto Restart.
- > ON/OFF Timer.
- > Weekly Timer.

MODES

- > Heating.
- > Cooling.
- > Dehumidification.
- > Ventilation.
- > Automatic.

WI-FI CONTROLS FOR VRF SYSTEMS

WI-FI MODULE



Wi-Fi

M-V-WiFi-2-IDU



M-V-WiFi-2-IDU module for VRF systems

All the main air conditioning settings at your fingertips on your smartphone

MULTIWARM presents the new M-V-WiFi-2-IDU module which allows access to remote control of the air conditioner via an app downloadable on a smartphone.

The MULTIWARM Wi-Fi kit can connect up to 80 indoor units.

Thanks to the M-V-WiFi-2-IDU app, you can manage the main operating parameters from your home with a simple domestic Wi-Fi connection, or away from home, with a simple Internet connection. With EWPE SMART by MULTIWARM, you can turn the air conditioner on, off, adjust the room temperature and air flow, and operate in cooling or heating mode, with just a few "touches" on your mobile phone. An intelligent app that controls comfort and energy savings with a beneficial effect on your bill.

EWPE SMART



Available for Android and iOS smartphones and tablets

Some examples of screenshots from iOS devices

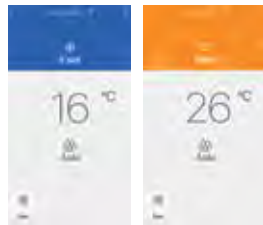

MAIN FUNCTIONS OF THE APP

- > Access security with account protected by credentials (User ID and PWD).
- > Individual control of individual units.
- > Turning on and off.
- > Selecting the operating mode.
- > Adjusting the set temperature.
- > Fan speed.
- > Weekly timer.
- > Heating activation 8° C (function that prevents the room temperature from falling below 8° C).
- > Silent mode.

VRF STANDARD INDIVIDUAL CONTROLS

INFRARED REMOTE CONTROL



M-V-CI-NB1-G

Standard for the following units:

wall, 8-way compact cassette, 8-way cassette, console, floor/ceiling

FEATURES

- > Clock.
- > Timer.
- > 4 fan speed levels + Turbo function.
- > Air distribution with vertical or horizontal flaps' swinging.
- > Setting the room temperature and displaying the indoor and outdoor temperature.

FUNCTIONS

- > I-Feel.
- > Sleep.
- > Energy saving (cooling).
- > Absence (heating).
- > Key lock.

MODES

- > Heating.
- > Cooling.
- > Dehumidification.
- > Ventilation.
- > Automatic.

WIRED CONTROL



M-V-CW-SD1-G

Standard for the following units:

ducted: low/high static pressure, 100% outdoor air ducted, enthalpy recovery unit, recovery unit with coil, recessed floor unit and EEV kit for AHU

Optional for other units

Touch key panel. Monochrome LCD display with white backlighting, soft touch buttons. Modern design, square lines. Intuitive remote control for the user and versatile thanks to the different functions.

FEATURES

- > Clock.
- > 24 hour timer for on/off.
- > 6 fan speed levels + Turbo function.
- > Air distribution with vertical or horizontal flaps' swinging
- > Integrated ambient temperature sensor.
- > View and set project parameters.
- > Receiving infrared signal from the remote control.

FUNZIONI

- > Sleep.
- > Quiet.
- > Auto Quiet.
- > X-fan.
- > Light.
- > Defrost.
- > Save.
- > Absence (heating).
- > Key lock.
- > Memory.
- > Filter cleaning reminder.

MODES

- > Heating.
- > Cooling.
- > Dehumidification.
- > Ventilation.
- > Automatic.

UP TO 16 INDOOR UNITS CAN BE CONNECTED, WHICH WILL OPERATE WITH THE SAME SETTINGS

See details of functions and application types, *page 144*

VRF OPTIONAL INDIVIDUAL CONTROLS

WIRED CONTROL FOR HOTEL



M-V-CW-HB2-G
Optional for all types of indoor units

Simplified panel particularly suitable for hotel applications. Backlit monochrome LCD display, mechanical buttons. Modern design, square lines, with glossy glass effect front panel. Very simple and intuitive remote control for the user and with simplified functions. Possible connection with automatic access management systems.

FEATURES

- > 6 fan speed levels + Turbo function.
- > Air distribution with vertical flaps' swinging.
- > Setting and displaying the room temperature.
- > Receiving infrared signal from the remote control.

FUNCTIONS

- > Defrost.
- > Key lock.
- > Memory.

MODES

- > Heating.
- > Cooling.
- > Dehumidification.
- > Ventilation.
- > Automatic.

UP TO 16 INDOOR UNITS CAN BE CONNECTED, WHICH WILL OPERATE WITH THE SAME SETTINGS

SMART WIRED CONTROL



M-V-CW-TW1-G
Optional for all types of indoor units

Smart touch screen panel with high resolution LCD display. Elegant design, square lines. Very advanced remote control complete with various functions, each viewable on a single interactive screen and easy to manage.

FEATURES

- > Clock.
- > 3 types of Weekly Timer.
- > 6 fan speed levels + Turbo function.
- > Air distribution with vertical or horizontal flaps' swinging.
- > Detection and display of ambient temperature.
- > Receiving infrared signal from the remote control.
- > Various customizations possible such as light regulation and stand-by time.

FUNCTIONS

- > Sleep.
- > Quiet.
- > Auto Quiet.
- > X-fan.
- > Light.
- > Defrost.
- > Save.
- > Absence (heating).
- > Key lock.
- > Memory.
- > Filter cleaning reminder.

MODES

- > Heating.
- > Cooling.
- > Dehumidification.
- > Ventilation.
- > Automatic.

UP TO 16 INDOOR UNITS CAN BE CONNECTED, WHICH WILL OPERATE WITH THE SAME SETTINGS

See details of functions and application types, *page 144*

Application types for VRF wired controls

M-V-CW-SD1-G
M-V-CW-HB2-G
M-V-CW-TW1-G

pag. 142-143

SINGLE CONTROL FOR THE MANAGEMENT OF A SINGLE INDOOR UNIT

Each indoor unit has its own independent control.

TWO CONTROLS FOR MANAGING A SINGLE UNIT

An indoor unit can be controlled by two wired controllers placed in different locations (Master/Slave mode).

SINGLE CONTROL FOR MANAGING MULTIPLE INDOOR UNITS (GROUP CONTROL)

A single wired controller can control up to 16 indoor units simultaneously.

TWO CONTROLS FOR MANAGING DIFFERENT INDOOR UNITS

The indoor units (maximum 16) can be managed by two wired controllers simultaneously.

Appendix

DETAIL OF CONTROL FUNCTIONS

- **Absence (heating only):** prevents the room temperature from falling below 8° C.
- **Defrost:** defrost function.
- **Energy saving/Save:** energy saving.
- **I Feel:** adjusts the room temperature according to that detected by the remote control to obtain maximum comfort.
- **Light:** brightness adjustment.
- **Memory:** in the event of a blackout, when the power is restored, it automatically restarts with the previous settings.
- **Quiet/Auto Quiet:** Silent mode.
- **Rapid:** when the unit is turned on, in direct expansion cooling or heating mode, it allows the set temperature to be reached quickly, improving indoor comfort.
- **Sleep:** night operation.
- **Turbo:** the unit operates at very high speed to quickly reach the cooling or heating temperature.
- **X-Fan:** allows the evaporator to dry to avoid the formation of mold and bacteria.

VRF OPTIONAL CENTRALIZED CONTROLS



M-V-CC-T32-G

Simplified centralized panel with 4.3" LCD touch screen display.

Modern and elegant design. Small footprint: recessed wall installation with a protrusion of only 11 mm.

You can manage up to 32 groups of indoor units (32 indoor units in total) distributed across up to 16 systems*. Possibility to: assign names to indoor units, select icons and create custom settings (background, backlight).

FEATURES

- > View and set project parameters.
- > Fault recording and access management.

FUNCTIONS

- > Single unit control: temperature setting, timer, fan speed, air distribution control with vertical or horizontal flaps' swinging and advanced functions (sleep, quiet, auto quiet, auxiliary heating, save, rapid, absence in heating).
- > Group management.
- > Centralized control of all indoor units.

MODES

- > Heating.
- > Hydronic heating.
- > 3D heating.
- > Ambient heating.
- > Cooling.
- > Dehumidification.
- > Ventilation.
- > Automatic.



M-V-CC-T255-G2

Centralized Touch Screen Panel. High resolution 7" touch screen LCD display.

Modern and elegant design. User-friendly operation.

Small footprint: recessed wall installation with a protrusion of only 14 mm.

You can manage up to 255 groups of indoor units (255 indoor units in total) distributed across up to 16 systems. Possibility to: assign names to indoor units, select icons and create custom settings (background, backlight).

Not compatible with RAC monosplit/multisplit units: wall-mounted (ACTION and AIRPRO PLUS) and console.

FEATURES

- > View and set project parameters.
- > Fault logging, alarm display and access management.
- > Programming (setting different programs).
- > **App control via the included Wi-Fi module (standard).**

FUNCTIONS

- > Single-unit control: temperature setting, timer, fan speed, air distribution control with vertical or horizontal swing and advanced functions (sleep, quiet, I-Feel, energy saving, weekly timer, filter-cleaning reminder, absence heating).
- > Group management.
- > Indoor temperature display.

MODES

- > Heating.
- > Cooling.
- > Dehumidification.
- > Ventilation.
- > Automatic.

OTHER VRF OPTIONAL CONTROLS

WEB-BASED MONITORING SOFTWARE



M-V-SOFT-Mon
Optional for all types of indoor units
(requires Gateway M-V-Gateway-Mon)

Remote control of on, off, temperature setting, operating mode and other parameters of any type of indoor unit or group of indoor units.

- > Real-time monitoring of system status and output of data for any errors and malfunctions.
- > Programming of units according to user needs and the intended use of the building.
- > Visualized graphical representation of the system structure and control modes of individual devices and/or groups of the entire project.
- > Consumption accounting.



M-V-Gateway-Mon
TCP/IP Network Gateway

GATEWAY FOR BACNET/IP AND MODBUS RTU/TCP MAX 255 I.U.



M-V-Gateway-LAN/Bacnet
Optional for all types of indoor units
(max. 16 systems or 255 indoor units)

- > Network gateway that supports connection to a building management system (BMS).
- > This network gateway features BACnet and Modbus communication protocols.
- > The high-efficiency, large-data communication system can monitor unit operation in real time and control up to 255 indoor units simultaneously.

MINI GATEWAY FOR MODBUS RTU



M-V-Gateway-Modbus
Optional for all types of indoor units
(max. 16 systems or 128 indoor units)

- > The mini Modbus network gateway enables connection to a building management system (BMS).
- > Remote control for single unit or groups of units for switching on, off, setting temperature, operating mode, fan speed, control lock with individual remote controls and real-time monitoring of operating parameters and error codes of the units.

OTHER VRF OPTIONAL CONTROLS

GATEWAY FOR CONNECTING LIGHT COMMERCIAL UNITS TO THE CENTRALIZED CONTROL



DMC-LCAC-Gateway

For light commercial units up to 7.1kW
ducted, compact cassette, cassette 84x84,
floor/ceiling.

One gateway is required for each indoor unit
(up to 255 gateways for each centralized control).

Interface to control light commercial R32 units up to 7.1 kW via the M-V-CC-T255-G2
centralized control..



Due to the continuous technological evolution of the products, we reserve the right to change the technical specifications in this catalogue at any time and without prior notice.

The products shown are only examples of the application types. The energy efficiency values refer to measurements carried out according to the following harmonised standards: EN14511; EN14825; EN16147.



multiwarm.it



TERMAL SALES S.r.l.

Via della Salute, 14 - 40132 Bologna - Italy

Tel. +39 051 41 33 111 | Fax +39 051 41 33 112

www.termal.it